

Report of the URSI Inter-Commission Working Group on SPS



June 2007

URSI Inter-commission Working Group on SPS

Blank

CONTENTS

Preface	v
List of Acronyms and Abbreviations	vii
Chapter 1 Background of SPS Research and Development	1
1.1 Scope of human life in the coming hundred years	1
1.2 Energy demand in the next 50 years	1
1.2.1 Predictions of demand and production of fossil fuels	1
1.2.2 CO ₂ emissions from fossil fuel use	2
1.3 Kyoto protocol and global warming	3
1.4 Sustainable energy resources	3
1.4.1 Terrestrial solar energy	4
1.4.2 Hydropower energy	4
1.4.3 Wind energy	4
1.4.4 Biomass energy	4
1.4.5 Geothermal energy	4
1.4.6 Hydrogen energy	4
1.4.7 Ocean thermal energy	4
1.4.8 Tidal power energy	4
1.4.9 Wave energy	4
1.5 Solar power satellite (SPS) as a sustainable power source	5
1.6 Nuclear energy	5
Chapter 2 Solar Power Satellite	7
2.1 SPS features	7
2.1.1 Basic concept	7
2.1.2 Clean energy source as a CO ₂ -free energy	7
2.1.3 Comparison with terrestrial photovoltaics	7
2.1.4 Economics	8
2.2 SPS systems	9
2.2.1 Space segment	9
2.2.2 Ground segment	9
2.3 SPS key technologies	9
2.3.1 Launch and transportation	9

2.3.2	Solar power generation system	11
2.3.3	Thermal control technology	12
2.3.4	Microwave power transmission on SPS	13
2.3.5	Target detection and beam control	16
2.3.6	Rectennas (rectifying antenna) and ground network	17
2.4	SPS research: State of the art	19
2.4.1	US research	19
2.4.2	Japanese research	21
2.4.3	European research	24
2.4.4	Worldwide activities	26
Chapter 3	SPS Radio Technologies	29
3.1	Microwave power transmission (MPT) technology	29
3.1.1	Use of EM waves to transmit energy	29
3.1.2	Characteristics of microwave power transmission	30
3.2	Microwave devices	30
3.2.1	Microwave semiconductors	30
3.2.2	Microwave vacuum tubes	31
3.2.3	Phase shifters and power dividers	31
3.2.4	Microwave devices, circuits and systems	31
3.3	Beam Control	32
3.3.1	Transmission efficiency	32
3.3.2	Phase synchronization among units	32
3.3.3	Retrodirectivity	32
3.3.4	Software retrodirective system	33
3.3.5	Effects of amplitude and phase errors of antenna array	33
3.3.6	Current antenna technology and future forecast	33
3.4	Rectennas	33
3.5	Measurement and calibration	34
3.5.1	Huge antenna array measurements on the ground and in space	34
3.5.2	Rectenna measurements	34
3.5.3	Self calibration of antenna gain and phase errors	34
3.5.4	SPS antenna test program	34
3.6	Spin-off technologies	36

Chapter 4	Influence and Effects of SPS	39
4.1	Interaction with space and the atmosphere	39
4.1.1	Atmospheric effects	39
4.1.2	Space plasma effects in the ionosphere	39
4.1.3	Effects of electric propulsion on the magnetosphere	41
4.2	Compatibility with other radio services and applications	41
4.2.1	Compatibility with other services such as radio astronomy	42
4.2.2	Reflection and thermal emission from solar cells	43
4.3	MPT effect on human health and bio-effects	43
4.4	Precautionary principle	45
4.5	Summary of pros and cons of SPS	45
4.5.1	Pros of SPS	45
4.5.2	Cons of SPS	45
4.5.3	Other issues of SPS	46
4.5.4	Pros and cons of SPS in Q&A	46
Chapter 5	URSI and SPS	49
5.1	Technologies	49
5.2	Environments	49
Chapter 6	Further Readings	51

Acknowledgments

Appendices

Appendix A	Microwave Power Transmission Activities in the World
Appendix B	Various SPS Models
Appendix C	US Activities (NASA reports)
Appendix D	Japanese Activities (JAXA reports)
Appendix E	European Activities (ESA reports)

PREFACE

This Report published by URSI (Union Radio Scientifique Internationale) is to provide a scientific background for discussions of issues related to Solar Power Satellites. URSI is a non-profit, non-governmental international union of scientists and engineers devoted to all aspects of radio science. Since its foundation in 1919, URSI has been a member of the International Council of Science (ICSU). A vast amount of knowledge and experience in radio science has been accumulated within URSI. Therefore it is appropriate that URSI be the organization to address all issues related to radio science.

While the world demand for energy has increased to dramatic levels, the carbon dioxide emissions from fossil fuels for energy production turns out a main cause of the global warming. Therefore it may be a good timing to give this overview of Solar Power Satellites (SPS) which has been proposed and investigated both technically and theoretically as a potentially clean energy source though there may be other issues related to radio use. URSI is the appropriate international organization to address all questions and problems related to radio science aspects of SPS. These problems and questions are explained and discussed in this document. Aspects not related to radio science, like launch and transport and other space technologies will only be briefly treated.

It should be stressed that URSI does not unanimously advocate SPS. Within URSI there are both advocates of SPS voices of concern and severe reservation. URSI sees its role in providing the necessary scientific background and a forum for unbiased discussion of advantage and disadvantages of SPS. URSI has established an inter-commission working group (ICWG) on SPS in 2002. The ICWG worked for the first three years to prepare this white paper. Since 2005, only its summary is separated, called White Paper, thoroughly discussed within the Board, approved by the scientific commissions and the national commissions, and published in Radio Science Bulletin. The rest is this document with Appendices and supplies detailed technical and scientific information. We hope the white paper will be helpful in facilitating the first step of technical and scientific discussion from both pro and con sides.

The Report is composed of a main text and Appendices. A full version including the White Paper is available in a CD format, while the first three parts without Appendices are available in a printed version.

Finally, the editors are deeply indebted to N. Shinohara and S. Kawasaki, J. Mankins, N. Suzuki,

and L. Summerer for writing many parts of chapter and/or appendices. They are also grateful to Yahya Rahmat-Samii, T. Itoh, M.T. Rietveld, Mike Davis, James Lin, Q. Balzano, Y. Omura, and T. Mitani, for writing some sections of this document. M. Inoue, R. Schillizzi, D. Emerson, M. Ohishi, A.R. Thompson, and W. van Driel have contributed from a view point of radio astronomy. The editors also thank P. Degauque, F. Lefeuvre, K. Schlegel, P. Wittke, R.M. Dickinson, T. Takano, M. Taki, D. Preble, and K. Hughes for their useful comments. Appendix D is a translation of reports in Japanese of JAXA SPS committee chaired by H. Matsumoto and some parts are used for the main texts. We thank M. Mori, H. Nagayama, and Y. Saito for administration and K. Tanaka, M. Oda, S. Sasaki, M. Utashima, N. Shinohara, K. Hashimoto T. Yoshida, M. Imaizumi, S. Toyama, H. Kawasaki, T. Yasutake, K. Suzuki T. Yoshida, M. Imaizumi, S. Toyama, T. Yasutake, K. Suzuki, and H. Kawasaki for original writing and checking the translation, and G. Maeda for English Translation. The members of ICWG on SPS are A. C. Marvin, Y. Rahmat-Samii, T. Ohira, T. Itoh, Z. Kawasaki, S. C. Reising, M. T. Rietveld, N. Shinohara, D. T. Emerson, W. van Driel, and J. Lin.

URSI Past President
Chair of the ICWG on SPS
Hiroshi Matsumoto

Secretary to the ICWG on SPS
Koza Hashimoto

List of Acronyms and Abbreviations

AC	Alternating current
AIA	Active Integrated Antenna
AIAA	American Institute of Aeronautics and Astronautics
ASEB	Aeronautics and Space Engineering Board
BMDO	Ballistic Missile Defense Organization
C&DH	Command and data-handling
CDS	Concept definition study
CED	Cumulated energy demand
CIGS	Copper indium gallium di-selenide
CNES	(French) National Center for the Study of Space
COP3	Conference of Parties III
CO2	Carbon dioxide
CTE	Coefficient of Thermal Expansion
CW	Continuous Wave
DC	Direct current
DOA	Direction of arrival
DOD	Department of Defense
DOE	Department of Energy
EDF	Electricite de France
EIA	Energy Information Agency
EMI	Electromagnetic Interference
EOTV	solar electric propulsion orbital transfer vehicles
ESA	European Space Agency
ESF	Environmental and safety factors
ESH	Environmental safety and health
ETO	Earth-to-orbit
FCC	Federal Communications Commission
FET	Field effect transistor
FY	Fiscal year
GEO	Geostationary Earth orbit
GN&C	Guidance, navigation and control
GW	Gigawatt = 1,000 MW
HDTV	High-definition television
HEDS	Human Exploration and Development of Space
HEMT	High electron mobility transistors
HLLV	Heavy lift launch vehicle
HTCI	HEDS Technology Commercialization Initiative
IAA	International Academy of Astronautics
IAF	International Astronautical Federation
IAC	International Astronautical Congress
IEEE	Institute of Electrical and Electronics Engineers
IEICE	Institute of Electronics, Information and Communication Engineers
IIASA	International Institute of Applied Systems Analysis
IPCC	Intergovernmental Panel on Climate Change

ISAS	Institute of Space and Astronautical Science
ISC	Integrated symmetrical concentrator
ISM	Industry, Science and Medical
ISS	International Space Station
ISU	International Space University
ITAR	International Traffic in Arms Regulations_
ITU	International Telecommunication Union
IWG	International Working Group
JAXA	Japan Aerospace Exploration Agency ¹
JUSPS	Japan-United States Joint Work Shop on Space Solar Power Systems
kW	kilowatt
kWe	kilowatt-electric
kWh	kilowatt-hour
kWm	kilowatt-mechanical ²
kWp	kilowatt-peak ³
LAN	Local Area Network
LEO	Low-Earth orbit
LNG	Liquefied Natural Gas
LH2	Liquid hydrogen
LSP	Lunar solar power
LOTV	Laser-propulsion OTV
LOX	Liquid oxygen
MESFET	Metal-semiconductor FET
METS	Microwave Energy Transmission in Space
METI	Ministry of Economy, Trade and Industry (Japan)
MHD	Magnetohydrodynamics
MINIX	Microwave ionosphere nonlinear interaction experiment
MMIC	Microwave Monolithic Integrated Circuit
MPD	Magnetoplasdynamic
MPM	Microwave Power Module
MPT	Microwave power transmission
MSC	Model system concept
MSFC	Marshall Space Flight Center
MW	Mega-watt = 1,000 kW
NASA	National Aeronautics and Space Administration
NEDO	National Energy Development Office (Japan)
NOAA	National Oceanic and Atmospheric Administration
NRC	National Research Council
OECD	Organization for Economic Cooperation and Development
OMB	Office of Management and Budget
OTV	Orbit Transfer Vehicle
PACM	Phase and amplitude controlled magnetron
PAE	Power added efficiency
PCM	Phase controlled magnetron
PFD	Power flux density
PLV	Personnel Launch Vehicle

PMAD	Power management and distribution
PV	Photovoltaic
RAMS	Robotic assembly and maintenance system
PHEMT	Pseudomorphic high electron mobility transistors
RFID	Radio frequency identification
R&D	Research and development
RF	Radio frequency
RLV	Reusable launch vehicle
RR	Radio Regulations
R&T	Research and technology
SAR	Specific absorption rate
SCTM	SSP Concept and Technology Maturation
SEE	Societe des Electricien et des Electronicien
SEPS	Solar electric propulsion system
SERT	SSP Exploratory Research and Technology
SHARP	Stationary High Altitude Relay Platform
SLI	Space launch initiative
SM&C	Structural materials and controls
SOI	Silicon on Insulator
SoL	Standard of Living
SOTV	Solar-thermal propulsion OTV
SPG	Solar power generation
SPS	Solar power satellite
SRES	Special Report on Emission Scenarios
SSP	Space solar power
SSPA	solid state power amplifier
SSPS	Space solar power system
SSPW	Space Solar Power Workshop
TIM	Technical interchange meeting
TMM	Thermal materials and management
TWTA	Traveling Wave Tube Amplifier
UN	United Nations
UNFCCC	United Nations Framework Convention on Climate Change
URSI	International Union of Radio Science ⁴
USEF	Institute for Unmanned Space Experiment Free Flyer
USGCRPUS	Global Change Research Program
VLBI	Very long baseline interferometry
VSWR	Voltage Standing Wave Ratio
WEC	World Energy Council
WPT	Wireless power transmission
YAG	Yttrium aluminum garnet

¹ formerly NASDA; National Administration of Space Development Agency

² mechanical kilowatt output of an engine. 1 horsepower (H.P.) = 0.746 kWm

³ a measure of the peak output of a photovoltaic system

⁴ Union Radio-Scientifique Internationale

Chapter 1 Background of SPS Research and Developments

1.1 Scope of human life in the coming hundred years

Mankind has recently enhanced its living standard and its population in an explosive way. In fact, the human population quadrupled and primary power consumption increased 16-fold¹ during the 20th century. The consumption of energy, food, and material resources is predicted to increase 2.5 fold in the coming 50 years. As a result of our efforts for better life, we have come to face, in this 21st century, serious global issues threatening our safe life or even our existence itself on our mother planet Earth. These are issues such as global warming, environmental degradation, declining nutrition on land and sea from rising CO₂, and rapid decrease of fossil reservoir. Since the living standard and the population of developing countries are increasing continuously, the demand of energy will be several times larger than that of today's requirement by 2050.

1.2 Energy demands in the next 50 years

One primary power source at present comes from fossil fuels such as oil, coal and natural gas. However, the fossil fuels have two serious factors that prevent them from being used for as a long-term primary power source. One is their limited amount; they will not last long if used at the same or higher pace than that of today. The other is that they emit carbon dioxide, a green house gas, which causes global warming.

1.2.1 Predictions of demand and production of fossil fuels



Fig. 1.2.1 Global production of oil. Lighter lines are predictions.²

On Nov. 9, 2004, Forbes reported that Russian oil exports may decrease within two years.³ "Further growth is possible only if price trends are good," a Russian expert said. Arabicnews.com reported that a sharp decrease in Syria's light crude oil exports is expected⁴ on Nov. 17. Such decrease of oil production is not surprising. M. K. Hubbert predicted in 1956 that crude oil production from U.S. (except Alaska) would crest in 1969. Figure 1.2.1 depicts the annual oil productions. The lighter lines are predictions according to Campbell and Laherrere's model, based in part on multiple Hubbert curves.² US and Canadian oil indicated by the brown line peaked in 1972 as predicted by Hubbert. Global annual oil production shown in the red line, recovered after falling in 1973 and 1979, but a more permanent decline is seen in recent years. Production in the former Soviet Union (yellow) has fallen 45 percent since 1987. A crest in the oil produced outside the Persian Gulf region (purple) now appears imminent. Figure 1.2.2 illustrates recent trends of the production that supports the prediction. The cost of

extracting the next barrel of oil or cubic meter of natural gas is continually escalating, threatening to ignite major and global inflationary pressures due to rising energy costs. Figure 1.2.3 indicates that the industry will likely need to add 100 million oil-equivalent barrels per day, which is close to 80% of today's production level, by 2015 to meet the demand according to an Exxon report.⁶

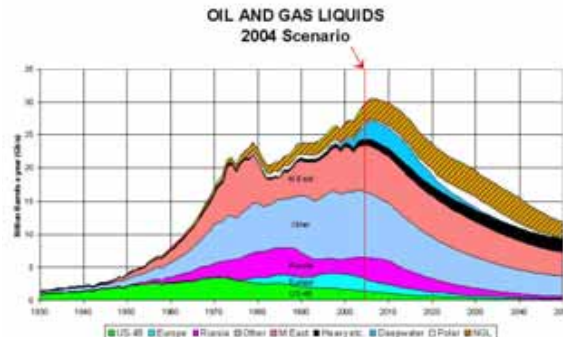

Fig. 1.2.2 Oil and gas liquids 2004 scenario from 1930 to 2050.⁵

Supplying Oil and Gas Demand Will Require Major Investment

Millions of Barrels per Day of Oil Equivalent (MBOE)

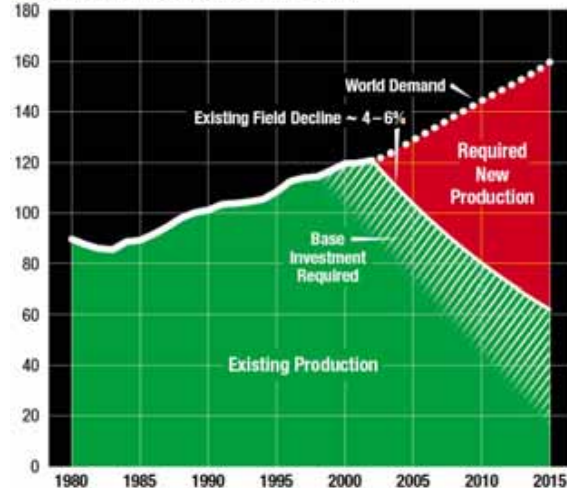

Fig. 1.2.3 Supplying oil and gas demand.⁶

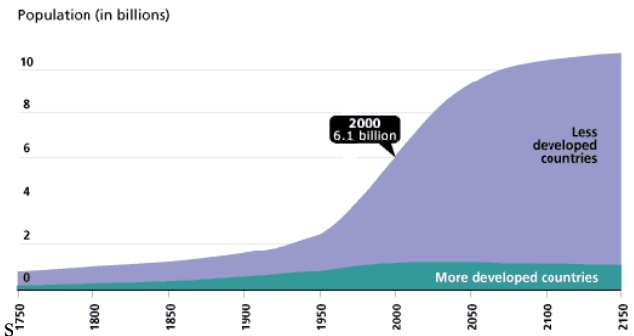

Fig. 1.2.4 World population prospect⁷

In 2000, the world had 6.1 billion human inhabitants. This number could rise to more than 9 billion in the next 50 years as shown in Fig. 1.2.4. This future population increase is

mostly due to very rapid increase in less developed countries although the number in more developed countries will be almost constant (about 1 billion) or even decrease.⁷

In the last century, despite two world wars, mankind experienced an explosive increase of both its Standard of Living (SoL) and its population (see Fig. 1.2.5). The explosive increase in the human population inevitably requires an exponential increase in the consumption of energy, food, and material resources. This fact has led us into today's global issues such as global warming, environmental change, and rapid decrease of the fossil reservoir.⁸ Matsumoto represented the consumption in an equivalent weight, SoL tons. This will not increase in developed countries, but will increase in developing countries due to their better living. Combining this with the population increase, the absolute shortage of resources becomes clear.

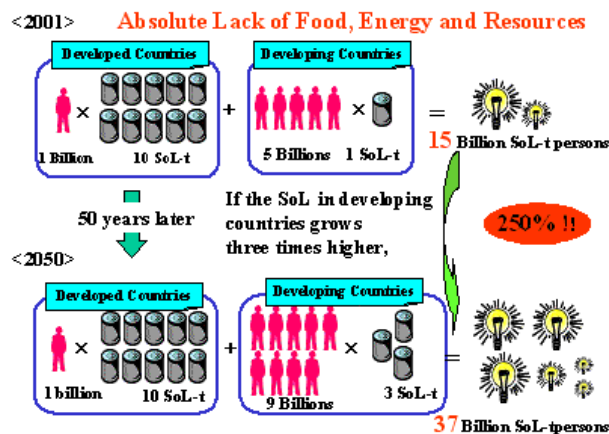

Fig. 1.2.5 Predicted absolute shortage of resources for human civilization in 2050.⁸

Figure 1.2.5 schematically depicts a simple calculation of the total resources required to maintain human civilization in 2050.⁸ The upper half panel presents the consumption of resources for living today in relative units of "SoL tons." The population in the developed countries is approximately 1 billion, and that in the developing countries is 5 billions. The SoL in the developed countries is ten times higher than that in the developing countries. In the developing countries the total resources consumed by humans today including energy, food and materials for daily and industrial demands, are 15 billion SoL-ton persons. By 2050, the population in the developing countries will reach 9 billion and their SoL will be at least three times higher than now. This increases the total resources needed to maintain the world economy and welfare of daily human life to 37 billion SoL-ton persons. This is more than 250% of today's requirements, and is not likely to be reached without the destruction of the environment of our mother planet Earth. It is highly probable that the demand of electrical power, 16,661 TWh in 2003, will increase at a much higher pace than other energy demands as the world becomes more industrialized and computerized.

1.2.2 CO₂ emissions from fossil fuel use⁹

Arrhenius predicted in the 19th century that CO₂ from fossil fuel burning could raise the infrared opacity of the

atmosphere enough to warm the Earth.¹⁰ The fossil fuel greenhouse theory has become more credible as observations accumulate and as we better understand the links between fossil fuel burning, climate change, and environmental impacts.¹¹ Atmospheric CO₂ has increased from 275 parts per million (ppm) before the industrial era began to 379 ppm in March 2004 as shown in Fig. 1.2.6. Some scientists suggest that it will pass 550 ppm this century. Climate models and paleoclimate data indicate that 550 ppm, if sustained, could eventually produce global warming comparable in magnitude but opposite in sign to the global cooling of the last Ice Age.¹² This 550 ppm (strictly speaking, ppmv: ppm by volume) was used as the most frequently used mitigation target.¹³

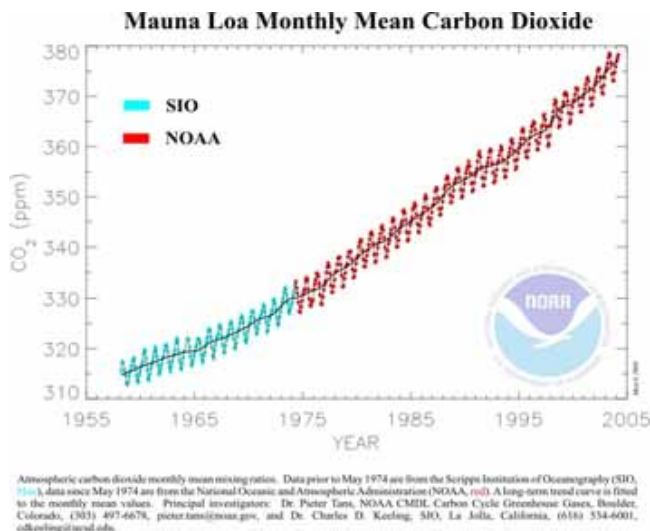

Fig. 1.2.6 Atmospheric carbon dioxide monthly mean mixing ratios. Data prior to May 1974 are from the Scripps Institution of Oceanography (SIO, blue), data since May 1974 are from the National Oceanic and Atmospheric Administration (NOAA, red). A long term trend curve is fitted to the monthly mean values.¹⁴

The future scenarios were published in the Intergovernmental Panel on Climate Change (IPCC) Special Report on Emission Scenarios (SRES).¹⁵ They are composed of four (A1, A2, B1, and B2) families and are summarized as follows. The A1 family describes a future world of very rapid economic growth, global population that peaks in mid-century and declines thereafter, and the rapid introduction of new and more efficient technologies. This family develops into three groups: fossil intensive (A1FI), non-fossil energy sources (A1T), or a balance across all sources (A1B). The A2 family describes a very heterogeneous world. Economic development is primarily regionally oriented and per capita economic growth and technological change are more fragmented and slower than in other storylines. The B1 family describes a convergent world with the same global population as in the A1 storyline, but the emphasis is on global solutions to economic, social, and environmental sustainability, including improved equity, but without additional climate initiatives. The B2 family describes a world in which the emphasis is on local solutions to economic, social, and environmental sustainability. It is a world with continuously increasing global population at a rate lower than A2, intermediate levels of economic development, and less

rapid and more diverse technological change than in the B1 and A1 storylines. While the scenario is also oriented toward environmental protection and social equity, it focuses on local and regional levels. Anthropogenic CO₂ concentrations resulting from the six scenarios are shown in Fig. 1.2.7, where IS92 is a scenario published in 1992 by IPCC. The fossil intensive A1FI group is worst and the sustainable B1 family is best.

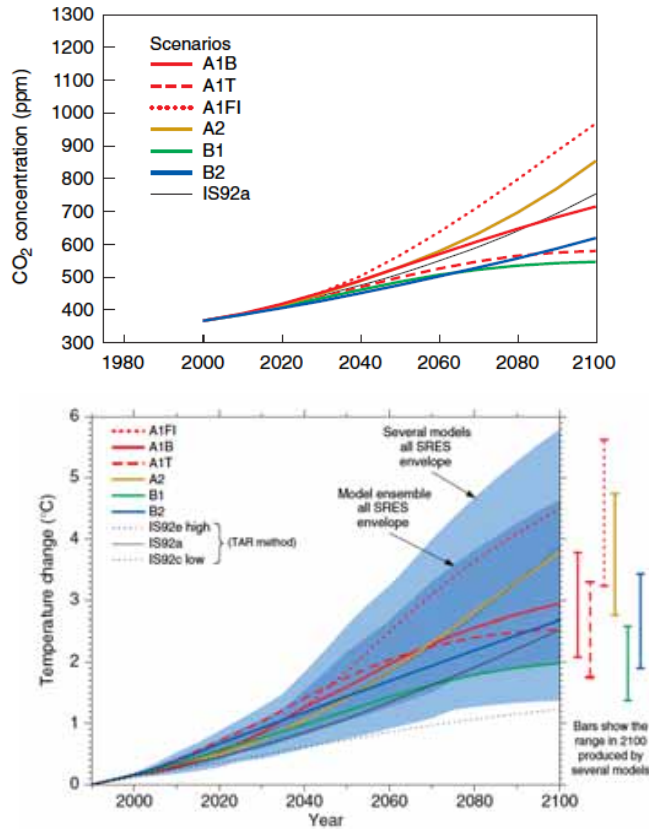

Fig. 1.2.7 CO₂ concentration and temperature change based on SRES scenarios.¹¹

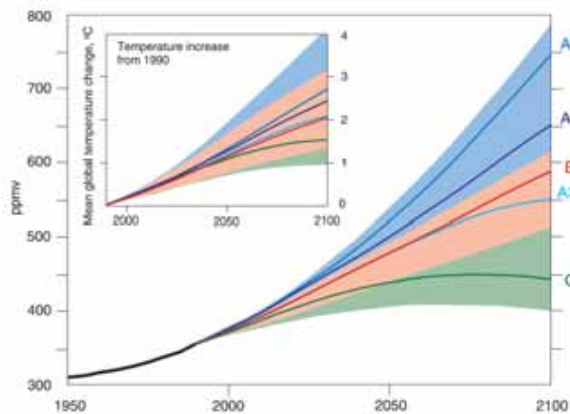

Fig. 1.2.8. Atmospheric CO₂ concentrations, in ppmv, historical development from 1950 to 1990 and in scenarios to 2100. The insert shows global mean temperature change compared with 1990 in degrees Celsius. The (substantial) model uncertainties are also indicated.¹⁶

Figure 1.2.8 plots atmospheric CO₂ Concentrations, in ppmv (parts per million by volume) and global mean temperature, historical development in various scenarios to 2100 worked by WEC (world energy council) and IIASA (International Institute of Applied Systems Analysis).¹⁶ This was published between IS92 and SRES scenarios. Case A family assumes high growth: A1 emphasizes oil and natural gas use; A2 coal-intensive; and A3 emphasizes the roles of natural gas, renewables, and nuclear). Case B is a reference. Case C is ecologically driven and has the lowest energy consumption and greenhouse gas emissions. Case C family is divided into C1, which assumes energy efficiency improvements, new renewables like solar, and termination of nuclear by 2100, and C2, which assumes nuclear power. The WEC believes curve C to be achievable, but only if we are really serious about being more careful and efficient in our use of energy, and also if we stimulate rather rapidly the growth of energy generation from renewable resources.

1.3 Kyoto Protocol and global warming

The Conference of Parties III (COP3), the Kyoto conference on climate change, was held in Kyoto, Japan, in 1997. In order to solve the crisis of the global warming, many countries agreed to specific targets for cutting emissions of greenhouse gases from developed countries at least 5% below 1990 levels during the period from 2008 to 2012. This agreement is called the Kyoto Protocol to the United Nations Framework Convention on Climate Change (UNFCCC). It was opened for signature on March 16, 1998, and closed on March 15, 1999. The Kyoto Protocol came into force on February 16, 2005 following ratification by Russia on November 18, 2004.

Nuclear energy is, apart from the difficulties of handling the waste, not regarded as a renewable energy source.

Table 1.3.1 CO₂ emission targets assigned to categorized countries required by Kyoto Protocol¹⁷

Country	Target (1990** - 2008/2012)
EU-15*, Bulgaria, Czech Republic, Estonia, Latvia, Liechtenstein, Lithuania, Monaco, Romania, Slovakia, Slovenia, Switzerland	-8%
US***	-7%
Canada, Hungary, Japan, Poland	-6%
Croatia	-5%
New Zealand, Russian Federation, Ukraine	0%
Norway	+1%
Australia	+8%
Iceland	+10%

* The EU's 15 member States will redistribute their targets among themselves, taking advantage of a scheme under the Protocol known as a "bubble." The EU has already reached agreement on how its targets will be redistributed.

** Some EITs¹⁸ have a baseline other than 1990.

*** The US has indicated its intention not to ratify the Kyoto Protocol.

Stabilizing the carbon dioxide-induced component of climate change is an energy problem. Establishment of a course toward such stabilization will require the development within the coming decades of primary energy sources that do not emit carbon dioxide to the atmosphere, in addition to efforts to reduce end-use energy demand.

1.4 Sustainable energy Sources

In spite of environmental issues and depletion of their resources, it is an undeniable fact that modern society heavily relies on the fossil fuels. According to International Energy Agency, fossil fuels provide about 80% of the total primary energy supply, as depicted in Fig. 1.4.1.¹⁹ To ensure a safe life for our children, we need to establish science and technology for a sustainable society. Such science and technology can be called Green Science and Technology (GST). Technology for stabilization of the carbon dioxide emissions is one of the key elements of the GST and requires development of primary energy sources that do not emit carbon dioxide to the atmosphere or that are renewable. Such sustainable energy technologies include terrestrial solar energy, hydropower energy, wind energy, and other energy systems based on natural resources.

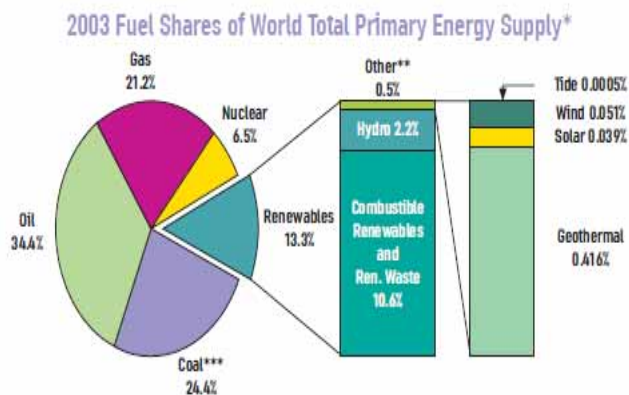

Fig. 1.4.1 Fuel shares of world total primary energy supply in 2003¹⁹

1.4.1 Terrestrial Solar Energy

Solar energy is clean and exhaustless, and the amount of the solar energy falling to the Earth per hour is nearly twice as much as the annual energy usage consumed by all mankind.

Photovoltaic (PV) cells, which are made of semiconductor devices, have already been put to practical use all the way from small goods such as watches and calculators to terrestrial solar power plants. Research and development of PV cells are conducted actively for the purposes of increasing conversion efficiency, reducing production cost, etc.

Solar thermal energy, which has been in widespread use for solar water heaters, is another utilization of terrestrial solar energy. Research and development of solar thermal power plants with optical concentration by mirrors are ongoing in some countries, whereas solar thermal power plants have not been put into commercial service due to economic and location conditions.

Basic problems of terrestrial solar energy are atmospheric attenuation, daily and seasonal variation, and affects by climate conditions. The average solar energy density in space near the

Earth is 1.37 kW/m². Atmospheric absorption reduces this to about 1 kW/m² at the surface of the earth on a sunny day. Solar energy weakens on cloudy and rainy days, and of course it can not be acquired at night. Maintenance of solar cell panels or solar collectors is also an important issue since contamination and dust can degrade production of electricity.

1.4.2 Hydropower Energy

Hydropower is an exhaustless and renewable energy that is converted into electricity by water flowing through turbines. It provided 2.2% of the world primary energy supply in 2003, according to International Energy Agency.¹⁹ Its capacity per plant varied from more than hundreds of MW to less than hundreds of kW. The output power per unit weight is 1,000 times greater than that of wind generation. Hydropower is CO₂ emission-free energy, whereas impacts on the natural aquatic environment, such as water pollution, and injury of aquatic animals passing through turbines are considered as environmental issues.

1.4.3 Wind Energy

Wind energy, which has been in widespread use for windmills, is clean, exhaustless and renewable, but not constant and is greatly affected by natural conditions. Due to much research, the cost of wind energy has dropped drastically (by 85%) during the last 20 years according to the US Department of Energy,²⁰ and wind power generators are operated as small-sized power plants in many countries. The worldwide wind energy capacity has been steadily increasing from 7.470MW in 1997 to 47.616MW in 2004, and is expected to be reach 100MW in 2008, according to a press release from World Wind Energy Association.²¹

1.4.4 Biomass

Biomass is renewable energy produced by biological resources such as natural botanical resources, agricultural crops, and animal waste. Biomass can be converted to various materials including bio-fuels, chemical materials, and electricity. Bio-fuels from botanical resources can balance out the CO₂ emission when burned, since they have already absorbed CO₂ by photosynthesis. Handling technologies, collection logistics, and infrastructure are important aspects of the biomass resource supply chain, according to the US Department of Energy.²⁰

1.4.5 Geothermal

This renewable energy is widely and abundantly distributed in volcanic countries. It has advantages over other sustainable energy sources from the viewpoints of the steady supply and environmental burdens. However, current geothermal power plants are an exhaustible resource since their resources are from shallow ground.

1.4.6 Hydrogen

Hydrogen is a plentiful resource produced from water or hydrocarbons, and the energy is clean and renewable since energy-yielding reaction produces water when it is converted to electricity. Hydrogen is also expected to be an energy transporter or transportation fuel. A top priority issue of hydrogen energy is to assure the safety against explosion.

1.4.7 Ocean Thermal

The energy is produced by temperature difference between hot water of ocean surface and cold water at a depth of several hundred meters. The validation phase of the pilot power plant is almost finished; nevertheless a commercial power plant is quite difficult to put into service due to economic matters.

1.4.8 Tidal Power

The clean, exhaustless, plentiful and renewable energy is obtained from the difference in tide levels, but daily variations of the energy are unavoidable. The largest power plant, the La Rance station in France, generates 240MW.²⁰

1.4.9 Wave

Wave energy is clean, exhaustless, plentiful and renewable, and its potential of generation in the world is more than 2000 TWh/year.²² Research has been conducted in many countries, especially in Europe. According to the ATLAS Project, many of the current uncertainties on cost and performance will need to overcome, although wave energy is nearing the end of its R&D phase.²³

1.5 Solar Power Satellite (SPS) as a Sustainable Power Source

In contrast to the existing renewable power sources, Solar Power from Space is promising in its 24-hour power supply capability and CO₂-clean nature as a new energy system that can ensure sustainable development of humanity. SPS was proposed several decades ago as a feasible candidate to satisfy the demand of sustainable and CO₂-clean power supply usable as base load.

US National Research Council evaluated the SPS activities called the SERT program as feasible and stated as follows in Summary in 2001.²⁴

The committee has examined the SERT program's technical investment strategy and finds that while the technical and economic challenges of providing space solar power for commercially competitive terrestrial electric power will require breakthrough advances in a number of technologies, the SERT program has provided a credible plan for making progress toward this goal.

Descriptions of the SPS, its concept, and related technologies especially in the field of URSI as well as scientific assessments and possible impact of the SPS systems are presented in the following chapters of this Report.

1.6 Nuclear Energy

Nuclear energy is CO_x and NO_x emission-free, but its relative share in the world primary energy supply in 2003 was only 6.5% according to the International Energy Agency.¹⁹

The most important and serious issues of nuclear power generations are proliferation and radioactive waste. Nuclear accidents make major impacts on nuclear energy policy of the world. Many European countries have decided to close their nuclear plants and freeze their nuclear programs due to risk considerations.

However, research and development of fast-breeder nuclear reactors and nuclear fusion energy continue in several countries in order to acquire a stable, long-term energy supply, although they have not come into commercial use.

REFERENCES

- ¹ J. R. McNeill, *Something New Under the Sun: An Environmental History of the Twentieth Century* (Norton, New York, 2000).
- ² Campbell and Laherere, *Scientific American*, 78-84, March 1998
- ³ <http://www.energybulletin.net/3064.html>
- ⁴ <http://www.arabicnews.com/ansub/Daily/Day/041117/2004111709.html>
- ⁵ <http://www.albany.edu/geosciences/oilngas.html>
- ⁶ A report on Energy Trends, ExxonMobil Feb. 2004
- ⁷ United Nations, *World Population Prospects, The 1998 Revision*; and estimates by the Population Reference Bureau.
- ⁸ H. Matsumoto, Research on solar power station and microwave power transmission in Japan: Review and perspectives, *IEEE Microwave Magazine*, vol. 3, no. 4, 36-45, December, 2002.
- ⁹ J. Houghton, <http://www.st-edmunds.cam.ac.uk/cis/houghton/lecture4.html>
- ¹⁰ S. Arrhenius, *Phila. Mag.* 41, 237 (1896).
- ¹¹ J. T. Houghton et al., Eds., *Climate Change 2001: Scientific Basis* (Cambridge Univ. Press, New York, 2001). The PDF version is available on the web; http://www.grida.no/climate/ipcc_tar/
- ¹² M. I. Hoffert, C. Covey, *Nature* 360, 573 (1992).
- ¹³ B. Metz et al., Eds., *Climate Change 2001: Mitigation*, The PDF version is available on the web; http://www.grida.no/climate/ipcc_tar/
- ¹⁴ http://www.research.noaa.gov/climate/images/carboncycle_co2mm.jpg
- ¹⁵ N. Nakicenovic and R. Swart, Eds., *Special Report on Emission Scenarios, IPCC, 2000*. Summary for policy makers is available on the web; <http://www.grida.no/climate/ipcc/spmpdf/sres-e.pdf>
- ¹⁶ *Global Energy Perspectives, IASA/WEC, 1998*.
- ¹⁷ http://unfccc.int/essential_background/kyoto_protocol/items/3145.php
- ¹⁸ *Economies in Transition: Countries of the former Soviet bloc - the Soviet Union itself and the formerly communist states of central and eastern Europe*.
- ¹⁹ *Renewables in Global Energy Supply, International Energy Agency, http://www.iea.org/*
- ²⁰ U.S. Department of Energy, *Energy Efficiency and Renewable Energy, http://www.eere.energy.gov*
- ²¹ Press releases, 5 March 2004 and 7 March 2005, *World Wind Energy Association, http://www.wwindea.org/*
- ²² Thorpe, T W. "An Overview of Wave Energy Technologies", A report produced for the Office of Science and Technology, AEA Technology Report Number AEAT-3615, 1998.
- ²³ The ATLAS Project, http://europa.eu.int/comm/energy_transport/atlas/homeu.html
- ²⁴ National Research Council, 2001, *Laying the Foundation for Space Solar Power: An Assessment of NASA's Space Solar Power Investment Strategy*, National Research Council, Washington, D.C.

Chapter 2 Solar Power Satellite

2.1 SPS Features

2.1.1 Basic Concept

The concept of the Solar Power Satellite (SPS) is very simple. It is a gigantic satellite designed as an electric power plant orbiting in the Geostationary Earth Orbit (GEO, see Fig. 2.1.1). It consists of mainly three segments: a solar energy collector to convert the solar energy into DC (direct current) electricity, a DC-to-microwave converter, and a large antenna array to beam the microwave power to the ground. The solar collector can be either photovoltaic cells or a solar thermal power generation. The DC-to-microwave converter of the SPS can be either a microwave tube system and/or a semiconductor system, or their combination. The third segment is a gigantic antenna array. The power beam must be controlled accurately to less than 0.0005 degrees.

The SPS system is composed of a space segment and a ground power receiving site. The latter uses a device to receive and rectify the microwave power beam. The device is called a rectenna (rectifying antenna). The rectenna system converts the microwave power back to DC power and is connected to existing electric power networks. The electricity sometimes can be converted to other forms of energy such as hydrogen.



Fig. 2.1.1 Solar Power Satellite (Artist's Concept)
©RISH, Kyoto University

The SPS system has that advantage of producing electricity with much higher efficiency than a photovoltaic system on the ground. Since SPS is placed in space in GEO, there is no atmospheric absorption, the solar input power is about 30% higher density than the ground solar power density, and power is available 24 hours a day (except for 70 minutes maximum during 42 days near the equinoxes as shown in Fig. 2.1.2) without being affected by weather conditions. It is confirmed that the eclipses would not cause a problem on a grid because their occurrences are precisely predictable. Solar flux is approximately eight times higher in space than the long-term surface average on the ground if the insolation is 4 kWh/m²/day.¹ With 50% MPT efficiency, this gives a net average of four. For the terrestrial system, however, the efficiency, additional space due to the loss explained in the next subsection, and cost of the storage system should be considered in order to supply electricity 24 hours a day. This ratio would become higher depending on the efficiency since 100% efficiency is assumed in the storage system. The possible SPS system issues to be discussed are the microwave power beam

impact on the existing communication networks and bio-bodies.

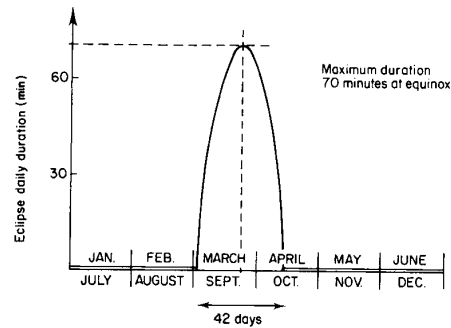

Fig. 2.1.2 Daily duration of eclipses as a function of the date.²

2.1.2 Clean CO₂-free Energy and energy source

The CO₂ emissions per kWh are compared for SPS, various fossil fuels, and nuclear power in Table 2.1.1.³ The CO₂ from the operations of the fossil fuel power generation systems mainly comes from burning of fuel, whereas the CO₂ emission from nuclear power plants mainly comes from the use of energy to produce nuclear fuel. Almost zero CO₂ emission is expected from SPS operation. As a result, the SPS System would release less CO₂ / kWh than nuclear power generation.

Table 2.1.1 Comparison of relative CO₂ emissions from different electricity generation systems (units: g CO₂ / kWh)

Generating system	Operations	Construction	Total
SPS	0	!!! 20	20
Coal	1222	3	1225
Oil	844	2	846
Liquefied Natural Gas (LNG)	629	2	631
Nuclear power	19	3	22

A huge, clean power source is to be developed for sustainable economic activities with a sufficient suppression of CO₂ emission. Only solar technologies can provide such a huge, clean power source in the near future. The terrestrial photovoltaics, wind, geothermal, and other natural resources depend on the environmental conditions and are neither stable nor sufficient.

2.1.3 Comparison with Terrestrial Photovoltaics

One may compare the output power from a space-based solar power system with that from a terrestrial photovoltaic array with the same area as the SPS rectenna area.⁴ For such a comparison, an average insolation⁵ of 5.7kWh/m²/day (in Phoenix, Arizona, or Las Vegas, Nevada, USA) and a conversion efficiency of 10% are assumed. In addition, the output power from the SPS rectenna is almost same as that of DC from a terrestrial array system with the same area lighted by sunlight.

The terrestrial photovoltaic system provides reduced construction costs. In addition, terrestrial systems can be installed on roofs and are compatible with other purposes such as factories, shopping malls, and parking lots. Since the

terrestrial system directly converts the light energy into the DC power, there is no concern about the influence of microwave exposure. There is no impact on the use of the radio spectrum, or on the night sky. Furthermore, the SPS needs more research for the microwave exposure effects on plants, birds, and animals to obtain public acceptance. The output from the terrestrial system is, however, affected by the daily and seasonal variation of insolation. This variation correlates to some degrees with the local demand for electric power. Energy storage systems must be added for base-load power applications.

No matter how efficient or inexpensive photovoltaic cells become, they cannot overcome the major difficulty of relying on solar power electrical generation from panels based on the ground.^{6,7} Terrestrial photovoltaics can work only when the sun shines, and the power is generated at full capacity during daylight hours when there is no cloud cover. Therefore, they are intermittent and unreliable unless equipped with storage systems. If one wishes that power from the sun could be collected 24 hours a day, 365 days a year and transmitted with ease to any point on the globe, one would need either further development of terrestrial energy storage technology or another source of electricity. The SPS system offers such a possibility except for a short time around the equinox as shown in Fig. 2.1.2. Another advantage the SPS system has over the land-based systems is absence of the atmosphere that absorbs the Sun's light. This increases the amount of light reaching each photovoltaic cell by approximately 30%. This nearly-continuous availability and high output mean that SPS can be relied upon as a base-load power source.

Minimum Daily Solar Radiation Per Month

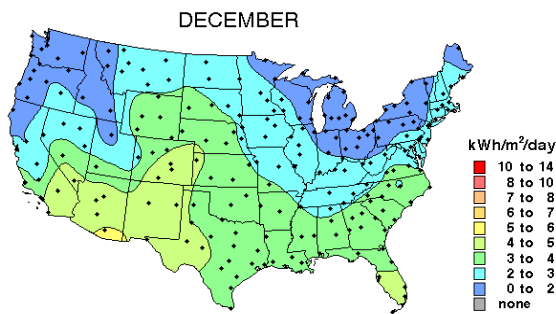

Two-Axis Tracking Flat Plate

Fig. 2.1.3 Minimum insolation by two-axis tracking flat plate⁸

Since 1 kW/m^2 can be obtained at full sun, we assume $24 \text{ kWh/m}^2/\text{day}$ as base load power, which corresponds to 24 hour full sun per day. If the terrestrial system is used as a base load, the impact of introducing the storage system should be taken into account. The very large solar call area becomes necessary as shown below.

1. In order for the storage system to supply enough energy even after rainy days, the minimum insolation should be taken into account.
2. As an example, the minimum daily insolation in the US is shown Fig. 2.1.3, where flat plate tracking the sun in both azimuth and elevation is assumed. This becomes much worse if horizontal plate is assumed. Let's assume the insolation, say $2 \text{ kWh/m}^2/\text{day}$. Then in order to obtain $24 \text{ kWh/m}^2/\text{day}$, the necessary power for the rest of a day, $22 (=24-2) \text{ kWh/m}^2/\text{day}$, must be stored.

3. If the storage efficiency is assumed to be 80%, the latter becomes $28 (=22/0.8) \text{ kWh/m}^2/\text{day}$.
4. In order to store this power under the insolation of $2 \text{ kWh/m}^2/\text{day}$, the necessary solar cell area is $15 (= (28+2)/2)$ times of that of the full sun operation.

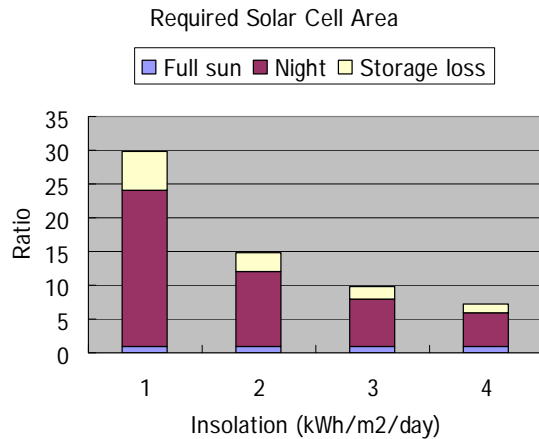

Fig. 2.1.4 Required solar cell area when a terrestrial solar power system is used as base load.

In order to use the terrestrial photovoltaic system as base load, as many as 15 times of the area for the full sun operation is necessary if the insolation is $2 \text{ kWh/m}^2/\text{day}$. This is too costly. This ratio is shown in Fig. 2.1.4 as a function of insolation.

The maintenance of the rectenna on the ground is easy and requires less cost. The GEO satellite does the solar tracking in space. Since it remains in a stationary position in the sky relative to the Earth, no tracking by the receiver is necessary. Therefore, there are no moving parts that raise the cost of maintenance. The land occupied by the rectenna can be used for another purpose. About 80% of the sunlight reaching the rectenna goes through the wire array to the ground surface.

The rectenna is extremely efficient in energy conversion; about 80% of the energy received at the ground is converted to usable electricity. The maximum energy density at the center of the radio beam is one tenth of the maximum sunlight energy rate, as measured at high noon in the desert. The density is less than the safe level outside the rectenna site. Thus the total SPS energy arriving at the rectenna site would be a fraction of the solar energy that arrives at each square meter of the site.

2.1.4 Economics

There are four technological challenges in the standard scenario for the SPS⁹: the PV module costs, the efficiency of microwave power transmission (MPT), the mass per peak kilowatt of the solar modules and the transmission system, the launch costs, and the maintenance costs to replace aging components. In particular, the MPT efficiency and the space module weight per kilowatt are purely technical issue. The targets are an efficiency about 50% for total MPT (DC-microwave-DC conversion), \$150/kg for launch cost, and 1kg/kW for space module. The SPS cost estimation is based on these assumed targets. If these targets are met, the power generation cost of the SPS is estimated to be 0.1 to 0.2 dollar per kWh. Innovative radio wave technologies have to be developed because improving MPT is most critical to reducing SPS cost. Whether the cost is the most important

reason to abandon the SPS development should also be discussed. It may be necessary to choose to develop a clean new energy source by paying some cost for the sustainability of our society.

Continuous developments would be necessary for innovative technologies, especially radio wave technologies.

2.2 SPS Systems

In the over-all SPS System, the output of the photovoltaic cell panel is converted to microwave energy, transmitted to the ground rectenna system, and converted back to DC. The aperture of a microwave transmitting antenna array can be designed with freedom of parameters such as the microwave operating frequency and the antenna element spacing. The dimensions of the rectenna site on the ground depend on the transmitting antenna size and the beam (power) collection efficiency. Assuming 70% conversion rate in the space segment, 90% beam (power) collection efficiency, and 80% conversion rate in the ground segment, the estimated over-all efficiency from DC (output of the solar panel) to DC (output from the rectenna system) is approximately 50%.

!! Fetter¹⁰ concluded "The probability the SPS could produce electricity more cheaply than solar arrays on earth is so small that any expenditure of funds and development on this concept would be unwise and unwarranted." A clear objection to this paper was, however, published by Smith¹¹ in the same journal.

2.2.1 Space Segment

The SPS space segment consists of solar cells, RF circuits and antennas, a sensor for the pilot signal, and a control unit for beam forming and retrodirectivity, and circuit power supply. A 1 GW SPS power plant has the following typical dimensions. The area of a solar cell panel is approximately 10 km² (2km x 5km) for production of 2GW DC power with the solar cell conversion efficiency of 15%. The transmitting antenna array will typically be 1km in diameter. The aperture distribution of the transmitting antenna is determined such as uniform profile or Gaussian profile based on the required beam collecting efficiency. Assuming an antenna element spacing of $0.75\lambda=3.8\text{cm}$ at 5.8GHz, a radiator weight density of 2.69g/cc, and 160 antenna elements, one could get 9.6 kg/ m² with this design approach.

2.2.2 Ground Segment

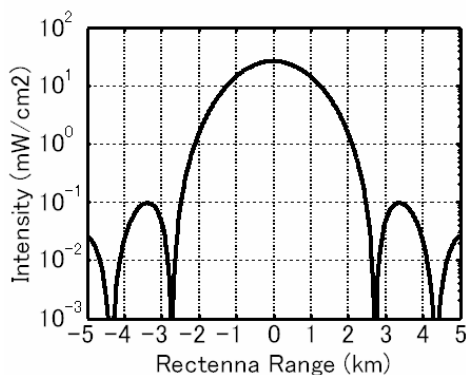

Fig. 2.2.1 Typical power density at a rectenna site (1km ϕ TX antenna with 10dB Gaussian power distribution)

A typical rectenna site is 4 km in diameter for a transmitting antenna diameter of 1km operating at 5.8 GHz. Under these conditions, 93% of the transmitted power is collected. The peak microwave power density at the rectenna site is 27 mW/cm² if a Gaussian power profile is assumed for the transmitter. The beam intensity pattern has a non-uniform distribution with a higher intensity in the center of the rectenna and a lower intensity at its periphery as shown in Fig. 2.2.1. The safety requirement for the microwave power density for humans is set to 1mW/cm² in most countries, which is satisfied at the periphery.

2.3 SPS Key Technologies

2.3.1 Launch and Transportation

The SPS is a gigantic space power station of ten thousand tons orbiting in Geostationary Earth Orbit (GEO). This is one hundred times larger than the present international space station in Low-Earth Orbit (LEO). Therefore, economical launch and transportation vehicles for massive material, such as the commercially available Falcon 9 from SpaceX, or other private commercial transportation providers, are required in order to realize an SPS that could provide power from space at a reasonable cost. Ariane 5 (Europe) can lift 18 tons; H-IIA (Japan), 10 tons; and Atlas IIAS (USA), 8.64 tons to LEO. The launch cost (FY'94) of the Ariane 5 is 118 to 130 M\$ (million dollars), and that of Atlas IIAS is 110 to 142 M\$. A Chinese rocket "Long March" is more economical. However, the SPS will be constructed for a long period and its cost cannot be estimated with these present rockets.

For the launch and construction of SPS, the following two vehicles are to be developed. One is a Reusable Transport Vehicle to transport heavy materials, at a reasonably low cost, to a LEO where assembly will be conducted. The other is an Orbital Transport Vehicle to lift the SPS from the LEO to the final orbit (GEO). These two rocket technologies are essential for realization of the SPS system.

2.3.1.1 Launch from Ground to LEO



Fig. 2.3.1 Future generations of transport systems proposed in USA¹⁴

Two transport systems are considered in the NASA's reference system:¹² (1) Heavy Lift Launch Vehicle (HLLV) and (2) Personnel Launch Vehicle (PLV). NASA is considering the use of methane (CH₄) and oxygen (O₂). They assume that the gross

lift-off weight of the HLLV is 11,040 tons with a payload to the LEO of 424 tons. A Japanese research group assumed two kinds of transport systems and simulated a launch cycle.¹³ One is a transport system with a 50-ton payload to LEO, the other is a 500-ton payload to LEO. As the weight of the first Japanese SPS model was 29,000 tons, 58 launches will be needed in one year to launch all materials for the SPS construction.

A new rocket to launch heavier materials to LEO is necessary for the realization of SPS. Future generations of transport systems have been studied¹⁴ without consideration of the SPS project (Fig.2.3.1). The SPS requires the 2nd or 3rd generation of RLV (Reusable Launch Vehicle) for supplying power from space at a reasonably low cost.

2.3.1.2 Transportation from LEO to GEO

The SPS is considered to be assembled in LEO and transported to GEO by solar electric propulsion orbital transfer vehicles (EOTV). To this end, a high-power magnetoplasmadynamic (MPD) thruster was designed, built and tested in the SCTM (SSP Concept and Technology Maturation) program, which is an SPS research program in the USA in FY2001.¹⁵ NASA Glenn Research Center's group developed 50 kW-class Hall thruster for construction of SPS. Many of ion thrusters have been developed for other purposes. The Japanese satellite "Hayabusa" was launched to deep space on May 9, 2003. Hayabusa used a microwave discharge ion engine system called, "μ10". The accumulated operational time of the "Hayabusa" is a world's record.¹⁶

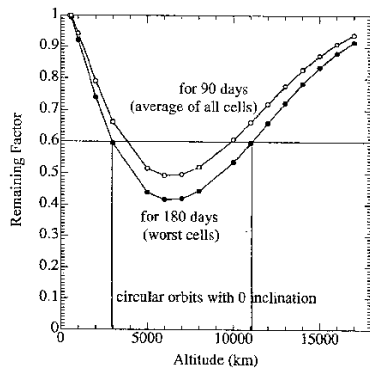

Fig. 2.3.2 Deterioration of efficiency of the solar cells during 6 months Altitude vs. Remaining Factor -

A combination of a heavy load transport system to LEO and transportation from LEO to GEO by the EOTV should be considered as a solution to economically constructing the SPS. The combination will be determined based on evaluations of the degradation of solar cell efficiency by the radiation belts (Fig. 2.3.2) and damage of SPS system by space debris (Fig. 2.3.3). Launch from the Earth is more expensive than from LEO to GEO. The problem of the EOTV is its low speed. Usually the EOTV carries materials from LEO to GEO half a year to over one year. The exposed time in the radiation belts and space debris with the EOTV is much greater than that with an RLV. A number of space debris collisions depends on the exposure time and the size of the payload. The degradation of the efficiency of the solar cells depends on the exposure time and the remaining factor of the solar cells. The relationship between the

transportation system and the degradation of the solar cell efficiency was simulated, yielding the following the results.¹⁷

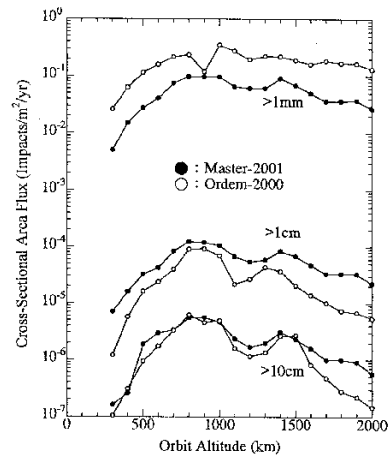

Fig. 2.3.3 Space debris flux below 2000 km (Orbit inclination 0 degree, AD2030)

(1) SSPS materials, except thin-film cells, are transported to GEO by reusable high-thrust OTVs (HOTVs) and solar electric propulsion orbital transfer vehicles (EOTVs) and assembled there. Thin-film cells are transported to GEO in a short time by HOTV in order to avoid cell degradation. The solar paddle of the reusable EOTV is used up after one round trip to GEO. The remaining factor of the cells on the EOTV must exceed 0.6 after one round trip. The result of the 1MeV-electron irradiation test of a-Si cells (see [4]) indicates significant degradation at a fluence¹⁸ of $5 \times 10^{15}/\text{cm}^2$. Since the fluence accumulated for 30 years on GEO is about $1.5 \times 10^{15}/\text{cm}^2$, this a-Si cell would be acceptable.

(2) If the remaining factor after 10 years on GEO is improved, RLV transportation of massive amounts of materials to the lower starting orbits can be reduced. The amount of the RLV transportation becomes flat when the remaining factor after 10 years on the GEO is between 0.93 and 0.94. We call this the "Critical Remaining Factor (CRF)" because the effect of the high specific impulse of the EOTV balances the influence of the cell degradation. If a remaining factor greater than the critical factor is realized, it is optimum to start the EOTV from an altitude of 500km.

(3) CIGS (copper indium gallium di-selenide) cells have a practically infinite lifetime in space as far as remaining factor is concerned.¹⁹ Therefore, degradation by radiation can be minimized by using CIGS cells, although both indium and gallium resources are in short supply.

(4) If the degradation characteristics of the thin-film Si cells cannot be improved, a propulsion system with a specific impulse exceeding that of the LOX/LH2 engine is required for the HOTV. The solar thermal propulsion and the laser propulsion are candidates. The minimum RLV transport amount for the SOTV (LOTV) is $2.04m_{\text{req}}$ at 8000km ($1.68m_{\text{req}}$ at 9000km).²⁰

(5) The assembly altitude should exceed 3000km in order to reduce the frequency of the debris impacts to a safe level, and the SSPS should not be assembled at altitudes between 3000km

and 11,000km in order to avoid degradation of the cells. Therefore, the assembly altitude is limited to above 11,000km and assembly at GEO would be appropriate.

To construct the SPS system, it is necessary to develop an economical large-capacity transport system.

2.3.2 Solar power generation system

To realize a commercial SPS, we have to resolve the following three technical issues regarding solar cells.

1. weight reduction
2. cost reduction
3. mass production feasibility

2.3.2.1 High Efficiency Solar Cells

Si and GaAs solar cells were studied and adopted in NASA's reference system.¹² They assumed that the efficiency of Si (GaAs) solar cells is 17.3% (20%) at AM0²¹ 28° Celsius.

The efficiency of the thick-film solar cells is theoretically limited to 20%, but they are heavy. In contrast, thin film solar cells for space applications with amorphous silicon (a-Si) or with CuInGaSe (CIGS cell) are expected to be much lighter, although their efficiency will be lower than that of the thick-film solar cells.²² The CIGS cells have the significant advantage that the remaining factor in the degradation of the solar cell efficiency is almost 1.²³

Instead of a-Si, II-V class elements can be used for the solar cells. After the US "fresh look study," the combination of small III-V class element cells with concentrators was extensively studied in SPS research groups.²⁴ Their main advantage is high efficiency and lower cell weight. They need a concentration factor greater than several hundreds.

The concentrator is important in another aspect. Most of the present SPS models adopt a sandwich structure; one side is the solar panel and the other side is a microwave transmitter. In these models, the area of the solar cells is so limited that a light-concentration technique is needed. The concentrator will play a key role in realizing bi-directivity: the solar cells on the front plane pointing to the Sun, the microwave transmitter on the back plane pointing to the Earth.

2.3.2.2 Mass Production Feasibility

The SPS requires more than 1GW solar cells for a single produced. The world production of cells for use on the ground was 391MW in 2001 and 1,194MW in 2004 (Fig. 2.3.4). It's a very high growth rate of mass production of the solar cells. In today's world, more than 80 percent of capacity is furnished with single crystal and polycrystal silicon solar cells (Table 2.3.1). CIGS and a-Si thin film solar cells will be the major sources around 2010. Information regarding mass production, deployment accumulation, and cost of solar cells is presented in Figs. 2.3.5 and 2.3.6.

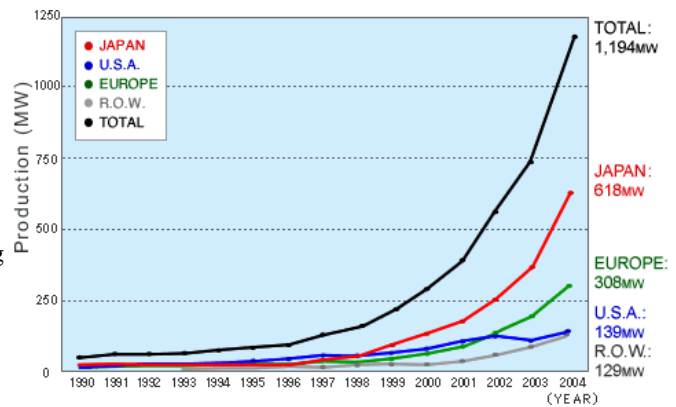

Fig. 2.3.4 Solar Cell/Module Production Volume (Worldwide)

Source: PV News (March 2005)

Table 2.3.1 Solar Cell/Module Production by cell technology (2003).

TABLE: 2003 world cell/module production by cell technology

Technology	Production (MW)					Proportion of total
	US	Japan	Europe	ROW	Total	
Polycrystalline	13.42	271.23	114.50	60.65	459.80	61.79%
Single crystal flat-plate	68.00	44.17	71.15	17.15	200.47	26.94%
Single and polycrystalline total	81.42	315.40	185.65	77.80	660.27	88.73%
Amorphous silicon	7.10	0.01	7.70	3.00	17.81	2.40%
Amorphous silicon indoor use	0.00	5.00	0.00	3.00	8.00	1.00%
Amorphous silicon total	7.10	5.01	7.70	6.00	25.81	3.40%
Crystal silicon concentrators	0.70	-	-	-	0.70	0.10%
Ribbon (silicon)	6.80	-	-	-	6.80	0.90%
Cadmium telluride indoor	0.00	0.00 ^a	-	-	-	-
Cadmium telluride outdoor	3.00	-	-	-	3.00	0.40%
Copper indium diselenide	4.00	-	-	-	4.00	0.54%
Microcrystalline Si/single Si	-	13.50	-	-	13.50	1.82%
Si on low-cost substrate	0.00	-	-	-	0.00	0.00%
A-Si on Cz slice	-	30.00	-	-	30.00	4.00%
Total	103.02	363.91	193.35	83.80	744.08	99.89%
Total indoor use (8.0 A-Si + 1.5 CdTe)					9.60	
Total terrestrial production					734.48	

^a Matsushita dropped CdTe for calculators.

Source: Paul Maycock, PV NEWS Annual review of the PV market 2004

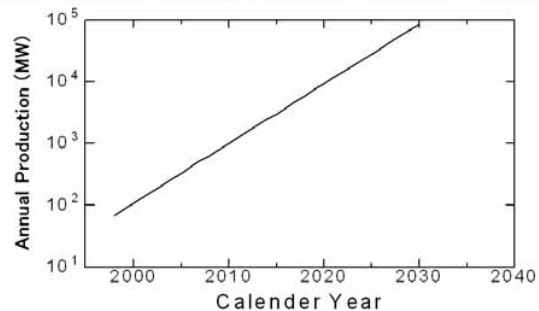

Fig. 2.3.5 Prediction of Solar Cell Production (From NEDO Website)

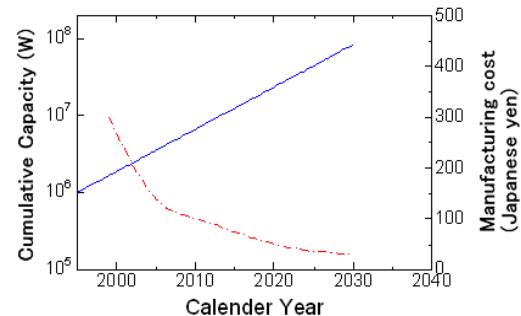

Fig. 2.3.6 Increasing applications and decreasing cost of solar cells (From NEDO Website)

2.3.2.3 Solar thermal power generation

Solar thermal power generation has a great potential since

higher efficiency and compactness is expected in the future compared with the photovoltaic generation. It will, however, be necessary to solve such problems as precise sun pointing control, light concentration, heat rejection, and life extension. The photovoltaic generation method will be put into practical use in initial SPS, and the solar thermal power generation method will be used after it will become matured.

Especially, the solar Brayton thermal power generation system is most developed and possible among the thermo-mechanical systems. Since NASA executed the research and development as a power supply for the International Space Station, it has technical buildup.^{25,26} Brayton cycle systems utilize a turbine, compressor and rotary alternator to generate electrical power using an inert gas working fluid. A recuperative heat exchanger between the turbine discharge and receiver inlet is used to improve cycle efficiency. Their unit conversion efficiency of 28% and the system conversion efficiency of 17% are achieved under the present situation.^{27,28}

On the other hand, highly effective systems that combines static thermoelectric conversion devices that are characterized by their long life and radiation resistance are studied.^{29,30,31} The compound device of the thermal electronic power and AMTEC (Alkali Metal Thermoelectric Energy Conversion) is a representative and is promising as a power supply for the Orbital Transfer Vehicle for a large amount of cargo shipment such as SPS.

2.3.3 Thermal Control Technology

Recently, SPS designers have noted the importance of a thermal control technology because recent SPS models adopt solar cells with concentrators in order to reduce the weight of solar cells and also adopt the solar cell – microwave ‘sandwich’ system modules in order to reduce heavy power lines. The concentrators and the sandwich modules cause thermal problems because of higher solar power inputs to the limited cell area. The reference system designed by NASA and DOE had large heat radiation panels behind solar cells to avoid the thermal problems. The thermal control technologies are important topics in SPS system design.

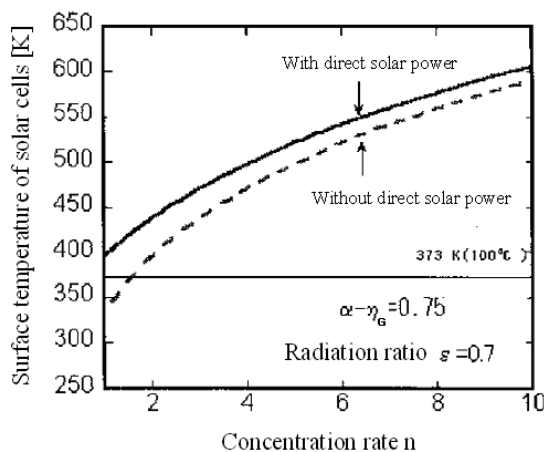

Fig. 2.3.7 Sun light concentration rate and balance temperature of generator (α absorption ratio of solar power; η_G , efficiency of solar cell)³²

! Figure 2.3.7 shows the relationship between the concentration

rate and the surface temperature of solar cells with normal heat radiation planes.³² A concentration rate of $n=2$ means that the solar power input is two times greater than the normal solar power input. Generally speaking, solar cells have to be used below 373 K. The SPS system requires more reduction in weight and size of the solar cells to reduce the transportation cost. However, the results shown in Fig. 2.3.7 indicate that the concentration rate is limited by the temperature of the solar cells, which means that there is a limit in downsizing of the solar cells. It also means that we have to develop a new heat radiation system to concentrate more solar power on the solar cells.

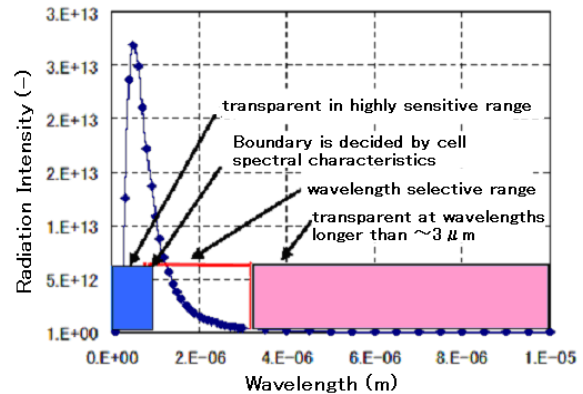

Figure 2.3.8 Effects of a spectral filter set between the sun and the solar cell³³

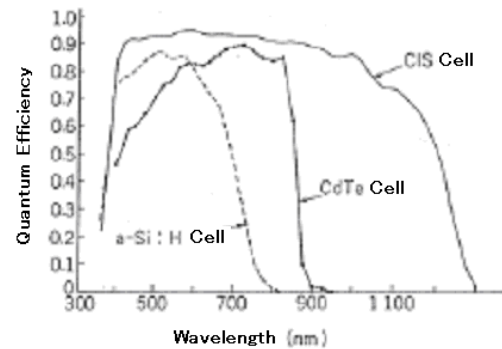

Fig. 2.3.9 Spectral sensitivities of solar cells³⁴

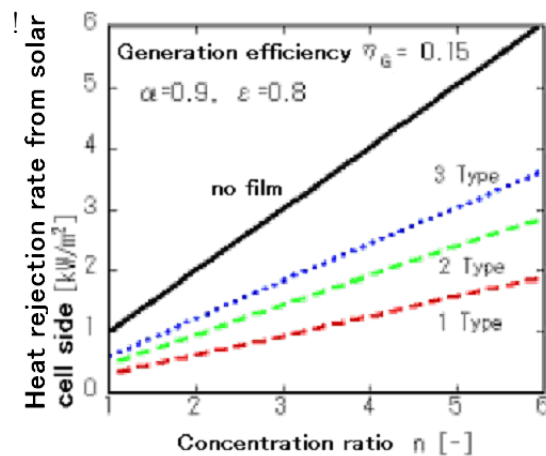

Figure 2.3.10 Relation between sunlight concentration ratio and heat rejection rate (with spectral filter attached)³³

As a countermeasure, a surface cover with a wavelength selection function is proposed in Japan to reduce heat input. The concept of the wavelength selection is shown in Fig. 2.3.8. Essentially, unwanted radiation is reflected so that it does not reach the solar cells. Thus, the solar cells can operate more coolly and more efficiently.

In Fig 2.3.9, three types of selectors are examined. Types 1, 2, and 3 mean a-Si:H, CdTe, and CIS types. In this study, we consider methods that have a quantum efficiency better than 0.5 for the solar generator and the generation efficiency is assumed to be 15% for these three types.

The effect of the sunlight concentration rate for each type is studied in Fig. 2.3.10. Each type releases some unwanted heat from the solar panels by thermal radiation. Type 1 appears to be especially effective. Compared with the case without spectral selection, Type 1 eliminates 32 percent of the heat. Type 3 blocks 60 percent of the heat, although its effectiveness is low. When there is no concentrator on the solar cells, excess heat is about 1 kW/m², but with Type 1, it is about 0.32 kW/m². With Type 3, it is about 0.60kW/m². It was found that Type 1 can dissipate the heat for six-time concentration when wavelength selection is employed. Without it, Type 1 can dissipate the heat for two-time concentration.

2.3.4 Microwave Power Transmission on SPS

2.3.4.1 System parameters of MPT on SPS

A huge phased array antenna with high efficiency must be used in the SPS MPT system. The phased array antenna is necessary for steering the power beam to a small rectenna target on the ground within 0.0005 degrees even though the transmitting antenna of the SPS will always move and fluctuate. The power beam must be generated and transmitted without much loss to maintain economy. An economic analysis in Japan³⁵ gives the optimum size of the transmitting phased array of a few kilometers and the optimum microwave power of a few GW at 2.45 GHz. For the same reason, a DC-RF conversion efficiency, which includes all losses e.g. in phase shifters, power circuits, and isolators, is assumed to be more than 80%. The beam collection efficiency, which is defined as the ratio of received microwave power at a rectenna site to emitted microwave power from the transmitting antenna, is assumed to be about 90%. Absorption by the atmosphere is to be less than 2%.¹² The weight is also an important parameter of the transmitting antenna for the cost estimation. The MPT system, which includes the generator, amplifier, phase shifter, and antenna, must weigh less than several kg/kW to reduce the transportation cost.

Table 2.3.2 Typical parameters of SPS transmitting antenna³⁶

Model	Old JAXA model	JAXA1 model	JAXA2 Model	NASA-DOE model
Frequency	5.8 GHz	5.8 GHz	5.8 GHz	2.45 GHz
Diameter of transmitting antenna	2.6 km ϕ	1 km ϕ	1.93 km ϕ	1 km ϕ
Amplitude taper	10 dB Gaussian	10 dB Gaussian	10 dB Gaussian	10 dB Gaussian
Output power (beamed to earth)	1.3 GW	1.3 GW	1.3 GW	6.72 GW
Maximum power density at center	63 mW/cm ²	420 mW/cm ²	114 mW/cm ²	2.2 W/cm ²
Minimum power density at edge	6.3 mW/cm ²	42 mW/cm ²	11.4 mW/cm ²	0.22 W/cm ²
Antenna spacing	0.75 λ	0.75 λ	0.75 λ	0.75 λ
Power per one antenna (Number of elements)	Max. 0.95 W (3.54 billion)	Max. 6.1W (540 million)	Max. 1.7 W (1,950 million)	Max. 185 W (97 million)
Rectenna Diameter	2.0 km ϕ	3.4 km ϕ	2.45 km ϕ	10 km ϕ
Maximum Power Density	180 mW/cm ²	26 mW/cm ²	100 mW/cm ²	23 mW/cm ²
Collection Efficiency	96.5 %	86 %	87 %	89 %

Table 2.3.2 shows some typical parameters of the SPS transmitting antenna. An amplitude taper on the transmitting antenna is adopted in order to increase the beam collection efficiency and to decrease sidelobe level in almost all SPS designs. A typical amplitude taper is called 10 dB Gaussian. With this taper, power density in the center of the transmitting antenna is ten times greater than that at the edge of the transmitting antenna.

2.3.4.2 Microwave generators and amplifiers

The technology employed for generating microwave radiation is extremely important for the SPS system. It should be highly efficient, very low noise, and have an acceptable weight/power ratio. A microwave energy transmitter often uses 2.45 GHz or 5.8 GHz in the ISM band (ISM=Industry, Science, and Medical). There are two types of microwave generators and amplifiers, the microwave tube and the semiconductor amplifier. These have contrasting electric characteristics. The microwave tube, such as a cooker-type magnetron, can generate and amplify high power microwaves (over kilowatts) with a high

voltage (over kilovolts). It is very economical. The semiconductor amplifier generate low power microwave (below 100W) with a low voltage (below fifteen volts). It currently is still expensive. There are some discussion concerning conversion and amplifier efficiency, however, the microwave tube has higher efficiency (over 70%) and the semiconductor has lower efficiency (below 50%). The weight of the MPT system is also important for reducing the transportation cost of the SPS. Microwave tube is lighter than a semiconductor amplifier when we compare the weight by power-weight ratio (kg/kW) because the microwave tube can generate and amplify higher power microwaves than can the semiconductor amplifier. Detailed research results concerning these microwave generators and amplifiers are described below.

(1) Phase and Amplitude Controlled Magnetron

The magnetron is a microwave tube suitable for the SPS MPT. The magnetron is widely used in microwave ovens and is a relatively inexpensive oscillator (below \$5). There is a net global capacity of 45.5GW for all magnetrons used in microwave ovens. Only magnetrons reach the manufacturing capacity for the SPS system. However, the cooker-type magnetron cannot be applied for the SPS because it is only a generator and we cannot control or stabilize the phase and the amplitude. As a result, we cannot construct a phased array antenna with cooker-type magnetrons.



Fig.2.3.11 Phased Array with 12 Phase Controlled Magnetrons at 2.45 GHz © RISH, Kyoto University

Some scientists have noticed that magnetrons are cheap, have high efficiency (over 70%), low noise, and have a high power-weight ratio. The cooker-type magnetron was considered a noisy device. However, it have been confirmed that spurious emissions from the cooker-type magnetron with a stable DC power supply are low enough and this magnetron can be applied in the MPT system.³⁷ Peak levels of higher harmonics are below -60 dBc, and other spurious emissions are below -100 dBc. The cooker-type magnetron is used as a voltage controlled oscillator in a phase-locked loop.^{38,39} The difference between the methods proposed in these papers is how the phase of the magnetron is controlled. An advanced phase-and-amplitude-controlled magnetron has been developed at Kyoto University, Japan.⁴⁰ They succeeded in controlling beam directions with phased arrays with phase controlled magnetrons operated at 2.45 GHz (Fig. 2.3.11) and 5.8 GHz.⁴¹ They have also

developed a light-weight phase-controlled magnetron called COMET, for Compact Microwave Energy Transmitter, with a power-weight ratio below 25g/W.⁴² The COMET includes a DC/DC converter, a control circuit of the phase-controlled 5.8 GHz magnetron, a heat radiation circuit, a wave guide, and an antenna. The power-weight ratio of the COMET is among the highest of all microwave generators and amplifiers.

(2) Traveling Wave Tube Amplifier (TWTA)

This is a high-gain microwave amplifier widely used in television broadcasting satellites and communication satellites. The TWTA has a proven track record in space. In 1980, it was not a serious candidate for SPS use because its efficiency was very low, around 30%. However, in recent years, TWTs use techniques called velocity tapering energy recovery⁴³ to achieve net conversion rates of around 70% (Fig. 2.3.12).⁴⁴ The TWTA has the following track record in space: 220W at 2.45GHz at 2.65 kg (the TWTA weighs 1.5kg, the power supply weighs 1.15kg), and 130W at 5.8 GHz at 2.15 kg (the TWTA weighs 0.8kg, the power supply weighs 1.35kg). Hence, they can deliver 12g/W and 16.5g/W, respectively.⁴⁵ They do not include the heat radiation circuit, waveguide, or antenna.

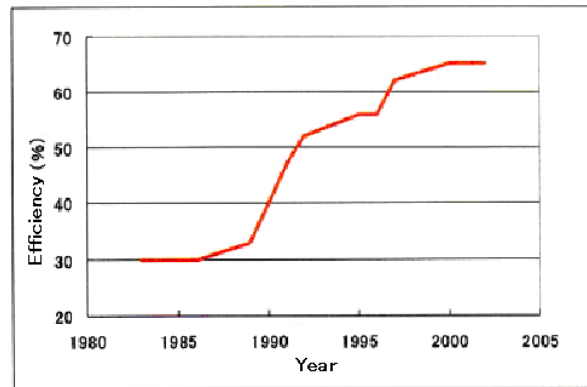

Fig.2.3.12 Trend of Efficiency of TWTA⁴⁴

Development trends of the TWT include an MPM and a phased-array TWT. The MPM (Microwave Power Module) combines the best aspects of TWTs, semiconductor amplifiers, and state-of-the-art power supply technology into one package. This makes the MPM a good candidate for space application because it has high conversion efficiency, and is small size and light.

(3) Klystron

The klystron is capable of delivering very high power (tens of kilowatts to a few megawatts). However it requires a ponderous power supply (it requires a heavy magnet). The klystron was selected for the NASA-DOE SPS model, because of its high conversion efficiency (76% if the device alone was considered), low harmonic emissions, and modest weight. The klystron is often used for uplinks (earth stations beaming to orbital satellites). A commercially available klystron can deliver 80kW of power at 2.45GHz with a power-weight ratio of approximately 100g/W. In C band, commercially available klystrons can deliver 3.2kW but require a 34kg device (permanent magnet) and a 135 kg power supply. It can achieve 40g/W. However, applications of the klystron for SPS

have not been discussed in the recent SPS research in contrast to magnetrons and semiconductor amplifiers.

(4) Semiconductor Amplifier

In 1980, semiconductor amplifiers were not serious candidates for SPS use. However, it has been growing as a promising MPT device in recent SPS research. There are many applications of semiconductor amplifiers to communication systems all over the world, and there are many researchers and users. The technologies are making steady progress on supports of researchers of semiconductor device, circuit, and systems.

Almost all semiconductor amplifier technologies are for communication use. Therefore, we have to analyze their characteristics from the MPT viewpoint. Examples of characteristics of various transmitters for space use are shown in Table 2.3.3.^{46,47} The spectrum between 2 and 4 GHz is called "S Band" in general. In all cases, it may seem that semiconductor transmitters are light in weight, but closer study reveals that they were quite heavy with the respect to the actual amount of microwave power they can deliver to the antenna.

Table 2.3.3 Characteristics of Semiconductor Radio Transmitters for Space Applications

Satellite	ETS-6	NSTAR	INT-7	JCSAT-3	Ref ⁴⁸	Ref ⁴⁹
Efficiency	31%	36%	29%	40%	45%	40%
Output	14W	40W	30W	34W	60w	111W
Weight	1.2kg	2.5kg	1.7kg	1.9kg	1.9kg	1.9kg
& g/W	85g/W	63g/W	57g/W	56g/W	31g/W	17g/W
Frequency	2.5GHz	2.5GHz	4GHz	4GHz	4GHz	2.5GHz

The other problem is efficiency. Some reports noted that it is possible to realize a PAE (power added efficiency = $(P_{out}-P_{in})/P_{DC}$) of 54%, efficiency of about 60%, at 5.8GHz. These are the best data in a laboratory. Semiconductor amplifiers require manufacturability and high efficiency, including efficiency of power source circuits, loss of isolator and circuits. The efficiency of the driver stage must also be considered if the gain of the final stage is not enough. Although the cost of semiconductor devices is now high since the semiconductor device for use in SPS is just now being developed, the price may be reduced through mass production. Therefore, in order to meet the requirements of light weight, compactness, and high efficiency for the transmitter, hybrid use of a magnetron with semiconductor devices is also attractive. Another requirement for the MPT application of semiconductor amplifiers is linearity. The maximum efficiency is usually attained at a saturation level, where the linearity between the input and the output is not guaranteed. Non-linearity causes strong harmonics that must be suppressed in the MPT. Therefore, dissolution of such difficult relationship between the efficiency and the linearity is necessary for the SPS MPT.

One trend in semiconductor amplifiers is the development of a new semiconductor device with increased output power and efficiency. Many advanced solid state devices have recently been developed and improved. For instance, wide-bandgap devices such as GaN have significant power outputs particularly at relative low microwave frequencies of 2.4 and 5.8 GHz. High efficiency with high power characteristic for the circuit is essential to solve heat problems in the transmission part of SPS. A novel circuit technology using a new device is strongly

desired to satisfy the needs of both high power and high efficiency simultaneously.

The other trend is development of a Microwave Monolithic Integrated Circuit (MMIC) to reduce size and weight, especially for mobile applications. Lighter transmitters can be realized with the MMIC devices. However, MMIC devices still have heat-release problems, poor efficiency, and low power output. However, the technical problems are expected to be solved by efforts of many engineers.

The optimum microwave generator and amplifier have not been selected yet. A hybrid system combining high power microwave tubes at the center of the array and low power semiconductor amplifiers at the edge of the array and/or MPM (microwave power module)-like hybrid amplifiers is a possible solution. It is important to continue the fundamental research and development of each device because it is still a long way before realization of the SPS. The MPT must satisfy noise requirements to avoid harmful interference with neighboring frequencies. Much more research is needed in this area.

2.3.4.3 Antennas

Various types of antennas on SPS have been considered. The antenna type is determined in relation with the microwave generator and amplifier. NASA-DOE's SPS adopted a slotted waveguide antenna with klystrons. An experimental SPS called SPS2000 in Japan adopted a slot antenna connected to semiconductor amplifiers.⁵⁰ It is 37 mm thick and has a density goal of 6.72 kg/m². Lightweight low profile models with metal posts and 3mm or 12mm thick have been proposed recently.⁵¹ In 1992, a 2.45GHz Japanese SPS model with dipole antennas and reflectors was proposed.⁵² It is expected to slash the antenna element weight from 20g to 10g. The system, including the case and heat radiator, consists of 64 elements. It would be 48cm × 48cm × 1mm × 2.69g/cc=620g in size and weight. Thus, 5.5kg/m² could be realized. Performance at 5.8GHz would also be pretty good. Assuming an antenna element spacing of 0.75λ=3.8cm, the same radiator weight density, and 160 antenna elements, one could attain 9.6 kg/ m² with this design approach. A novel concept of partial drive has been proposed and studied to drastically reduce the driven elements in an array of small radiators.⁵³

A phased array with middle size parabolic antennas has been proposed in Japan to reduce of the number of elements.⁵⁴ Microstrip antennas can also be applied for the transmitting antenna. However, the weight of the dielectric base is a problem. The weight of the antennas is also important for reducing transportation cost. There is a light weight antenna for space use, but not for the SPS. NASDA achieved a 2.8g/m² antenna in Ka-band. The features are 12 elements (not powered by electricity), two layers, a batch antenna, glass ceramics with ϵ_r =5, 5x5cm in size, and 7g in weight.

2.3.4.4 Matching between microwave generators and amplifiers and antennas

As discussed in section 2.3.4.1, the optimum to be economic size of the transmitting phased array and microwave power are calculated around a few km and over a few gigawatts. This means that the microwave power from one antenna element is much smaller than that from one microwave tube or high power

(over a several tens watts) semiconductor amplifier. It also means that phase shifters have to be installed after the microwave generation and amplification stage (Fig.2.3.13) if microwave beams are to be steered over 5 degrees without grating lobes. In that case, development of low-loss phase shifter is very important for constructing a phased-array antenna with high efficiency. However, the phase shifter problem will be solved if the microwave beam will be steered within 0.1 degrees because **such many** phase shifters do not need to be installed without grating lobes with a large sub-array. Another way to solve the phase-shifter problem is to use low-power amplifiers after the relatively high loss phase shifters (Fig. 2.3.14).

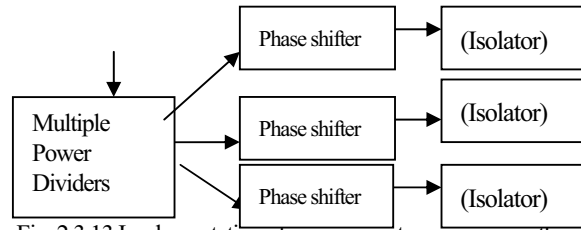

Fig. 2.3.13 Implementation of microwave transmission with a high power microwave oscillator and phase-shifters for high precision control of microwave beam direction to large angles without grating lobes³⁶

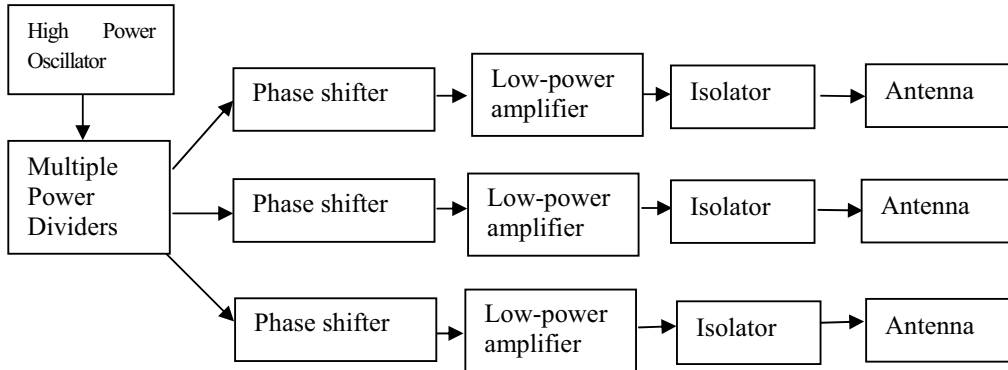

Fig. 2.3.14 Implementation of microwave transmission with phase shifters and low-power amplifiers for high-precision control of microwave beam direction without grating lobes³⁶

2.3.5 Target detection and beam control

It is important that all of the transmitted microwave power is collected in the rectenna site on the ground. As described in section 2.3.4, absorption by the atmosphere is to be less than 2%. Accuracies of target detection and beam forming are very important in increasing the beam collection efficiency.

2.3.5.1 Retrodirective target detection

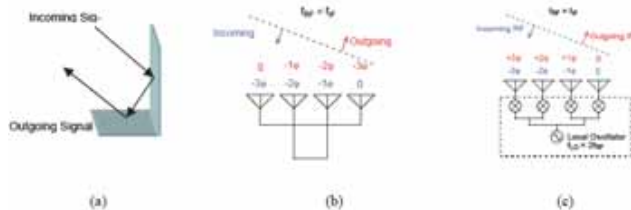

Fig. 2.3.15. (a) Two-sided corner reflector. (b) Van Atta Array. (c) Phase-conjugating array. (Sung et al., <http://hac.hawaii.edu/tcwct03/papers/s16p03.pdf>)⁵⁵

A retrodirective target detection technique is adopted in all SPS designs. Retrodirective detection can be realized by a number of different techniques.⁵⁵ The most basic is a corner reflector (Fig. 2.3.15(a)).⁵⁶ The corner reflectors consist of perpendicular metal sheets, which meet at an apex. Incoming signals are reflected back in the direction of arrival through multiple reflections off the wall of the reflector. A Van Atta array⁵⁷ is also a basic technique for developing a retrodirective system (Fig. 2.3.5.1(b)). This array is made up of pairs of

antennas spaced equidistant from the center of the array, and connected with equal-length transmission lines. The signal received by an antenna is re-radiated by its pair, thus the order of re-radiating elements are inverted with respect to the center of the array, achieving the proper phasing for retrodirectivity.

A usual retrodirective system consists of transmitting and receiving antennas and a phase conjugate circuit. A signal transmitted from the target, e.g. from the rectenna site on the ground to the SPS, is received and re-radiated through the phase conjugate circuit to the direction of the target. The signal is called a pilot signal.

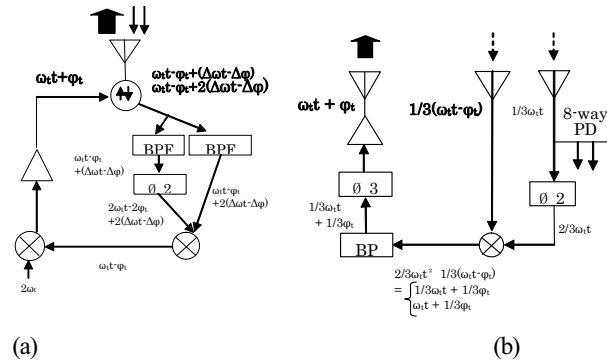

Fig. 2.3.16 Phase conjugate circuit developed in Kyoto University © RISH, Kyoto University

There are various types of phase conjugate circuits for communication use and for SPS use. The UCLA research group uses phase-conjugating mixers.⁵⁸ Phase conjugation with heterodyne mixing uses an LO signal at a frequency twice as high as the pilot signal frequency. In the UCLA's system, frequencies of the pilot signal and microwave power beam are the same. Kyoto University in Japan has developed two types of

the retrodirective systems.⁵⁹ One has two asymmetric pilot signals, $\omega_t + \Delta\omega$ and $\omega_t + 2\Delta\omega$, and the LO (local oscillator) signal of $2\omega_t$ (Fig. 2.3.16 (a)). The other is pilot signals with one third of the transmitting frequency and the LO signal is generated from the pilot signals (Fig. 2.3.16 (b)). The latter system solves the problem caused by fluctuation of the LO and the pilot signal that cause phase errors because the fluctuations of the LO and the pilot signals are synchronous. Mitsubishi Electric Corporation in Japan developed PLL-heterodyne type retrodirective system in which different frequencies for the pilot signal and the microwave power beam, 3.85 GHz and 5.77 GHz, were used.⁶⁰

These retrodirective systems adopt analog circuits for phase conjugation. Although it can control the beam at a very high speed, the beam can be directed to a single direction of a target. The retrodirective system needs both target detection and beam forming. Therefore, if we separate the target detection from the beam forming, we can direct the microwave power beam in any desired direction. This concept is called a software retrodirective system. A computer is used to detect targets with the phase and the amplitude data from the pilot signal and for beam forming with calculation of the optimum phase and amplitude distribution on the array. We can apply an advanced algorithm such as the MUSIC algorithm for target detection. We need phase shifters for the beam forming instead of the phase conjugate circuit. Kyoto University in Japan and Texas A&M University in the USA have independently developed software retrodirective systems.^{61,62}

2.3.5.2 Beam forming techniques

There is a room for forming a desired beam, e.g. with low sidelobe levels, if the software retrodirective system is adopted in an SPS. Some algorithms are used for optimum beam forming; these include neural networks, genetic algorithms, and multi-objective optimization learning. The optimum is able to suppress sidelobe levels, to increase beam collection efficiency, and to generate multiple power beams. We can select goals of optimization and algorithm freely with considering the time required for calculation.

A phase standard is very important for steering microwave power beams in a desired direction, both for beam forming with the software retrodirective systems and for retrodirective systems with phase-conjugate circuit. If the phase or frequency standard like the local oscillator (LO) signal is different on the array, we cannot steer the microwave beam to the desired direction. The best way is to use only one oscillator for the standard of the phase and frequency for a phased array of exceeding one kilometer in size with more than a billion elements, but this is impossible. A better way is to use some oscillators on some group of sub-phased array and synchronize the oscillators with each other. Some trials have been carried out. One is wireless synchronization of separated units. The present accuracy of wireless synchronization is below 0.6 ppm of the frequency and below 3.5 degrees of phase error.⁶³ Another is self-synchronization with some data sent from the rectenna site.⁶⁴ In this method, the phase in a part of the arrays is changed and a resultant change of the microwave beam intensity is measured at the rectenna site. The change gives us information

on phase corrections. Both methods are under development, and a highly accurate phase synchronous system is needed for SPS. The other important point for accurate beam forming is suppression of phase, frequency, and amplitude errors of the elements in order to maintain high beam collection efficiency and to suppress the sidelobe level and reduce interference with communication systems. The calculated phase error of the elements is required to be below 5 degrees in an SPS-MPT system.⁶⁵ The error includes phase errors in every stage, target detection, microwave generation and amplifier, phase synchronization, and phase shifter. The error also includes a structural error. We need a more accurate MPT system for the SPS.

2.3.6 Rectennas and ground network

The SPS system will require a large receiving area with a rectenna array and the power network connected to the existing power grids on the ground. Although each rectenna element supplies only a few watts, the total received power is in the gigawatts. The existing power network is much larger: hundreds GW. It is important to study the rectenna element, array, and networks step by step to realize the SPS system.

2.3.6.1 Rectenna element

The word “rectenna” is formed from “rectifying circuit” and “antenna.” The rectenna and its word were invented by W. C. Brown in 1960's.⁶⁶ The rectenna receives microwave energy and converts it to DC electricity. The rectenna is a passive element with a rectifying diode, and is operated without any extra power source. The rectenna has a low-pass filter between the antenna and the rectifying diode to suppress re-radiation of higher harmonics. It also has an output smoothing filter. The rectenna can have any type of antennas including dipole, Yagi-Uda antenna, microstrip antenna, or even parabolic antenna. A specific antenna gives an effective aperture related to its gain. Input microwave power to the rectifying circuit is determined by the effective aperture of the antenna and microwave power density. The rectenna can have any type of rectifying circuit such as single shunt full-wave rectifier, full-wave bridge rectifier, or other hybrid rectifiers. The circuit, especially the diode, mainly determines the RF-DC conversion efficiency. Silicon Schottky barrier diodes have usually been used for rectennas. New diode devices like SiC and GaN are expected to increase the efficiency.

The single shunt full-wave rectifier is often used for the rectenna. It consists of a diode inserted to the circuit in parallel, a $\lambda/4$ distributed line, and a capacitor inserted in parallel. In an ideal situation, 100% of the received microwave power should be converted into DC power.⁶⁷ Its operation can be explained theoretically in the same way as an F-class microwave amplifier. The $\lambda/4$ distributed line and the capacitor allow only even harmonics to flow to the load. As a result, the wave form on the $\lambda/4$ distributed line has a π cycle, which means the wave form is a full-wave rectified sine form. The highest RF-DC conversion efficiency among developed rectennas is approximately 90% at 4W input of 2.45 GHz microwave. Other rectennas have approximately 70 to 90% conversion efficiency at 2.45GHz or 5.8GHz.

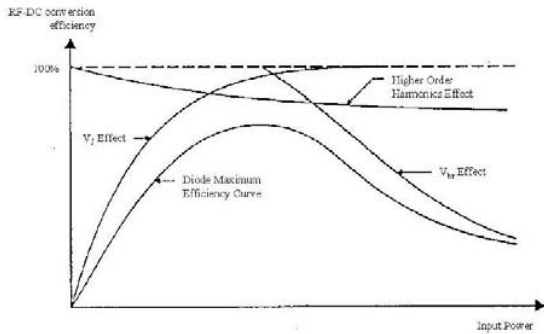

Fig. 2.3.17 Typical rectenna RF-DC conversion efficiency⁶⁸

The RF-DC conversion efficiency of the rectenna depends on the microwave power input intensity and the connected load. It has the optimum microwave power input intensity and the optimum load to achieve maximum efficiency. When the power or load is not optimum, the efficiency is nearly 0% (Fig. 2.3.17). The conversion efficiency is determined by the diode characteristics. The diode has its own junction voltage and breakdown voltage. If the input voltage to the diode is lower than the junction voltage or higher than the breakdown voltage, the diode does not rectify the input microwave. As a result, the RF-DC conversion efficiency drops when the input is lower or higher than the optimum.

Currently, there is research being conducted in the field of rectenna development. It is important to research and develop new rectennas that are suitable for a weak microwave in the microwatt range that can be used in experimental power satellites and IC tags. An experimental satellite on LEO will transmit a weak microwave to the ground because the microwave power and size of transmitting antenna on the experimental satellite will be limited by the capacity of the present launch rockets. This rectenna should somehow be integrated with the antenna, and, if possible, a new diode should be developed. There should also be novel approaches to designing rectifiers.

2.3.6.2 Rectenna Array

The rectennas will be used as an array. Mutual coupling and phase distribution are usually problems for the antenna array. However, the rectenna array is connected in the DC phase, not in microwave phase. Therefore, its problems differ from those of the antenna array.

It was reported that total output DC power of the rectenna array is less than the sum of individual output DC powers of the rectenna elements.⁶⁹ The power decrease for series connection exceeds that for parallel connection due to the RF-DC conversion efficiency of the rectenna elements shown in Fig. 2.3.5.1. The connection equalizes current or voltage on the rectenna and moves the rectenna from the optimum point. Simulation and experiments confirmed that current equalization in series connection is worse than voltage equalization in parallel connection.⁷⁰ There is an optimum connection for the rectenna array.

The SPS requires a rectenna array with a diameter of 2km. Although much has been conducted on rectenna elements, only a few rectenna arrays were developed and used for experiments. The largest rectenna array in the world is that used for a ground

to ground experiment in Goldstone by JPL, USA, in 1975.⁷¹ The size was 3.4 m x 7.2 m = 24.5 m². It converted 2.45 GHz microwave energy to 34 kW DC with 82.5% efficiency. A rectenna array with a size of 3.54 m x 3.2 m was developed for a ground-to-ground experiment conducted by Kyoto University, Kobe University, and Kansai Electric Corporation in 1994.⁷² They used 2,304 rectenna elements at 2.45 GHz and investigated the rectenna connection problem. Kyoto University has several types of rectenna arrays operating at 2.45 GHz and 5.8 GHz.⁷³ These sizes are approximately 1m². Another rectenna array with a size of 2.7 m x 3.4 m was developed for MPT in a fuel-free airship experiment conducted by the Communication Research Laboratory (CRL; currently NICT) in Japan and Kobe University in 1995.⁷⁴ There is a large gap between these arrays of a few meters in size and the SPS array of kilometers in diameter. Research on larger-scale rectenna arrays is required.

2.3.6.3 Ground network

It is widely assumed that a commercially feasible SPS is on the order of gigawatts. It delivers significant electric power and can contribute to any national power grid. The technology for connection to the grid already exists, although the output of the SPS is a direct current. The output of thermal or nuclear power plant is AC because they must first drive turbine-generators.

As noted above, an SPS rectenna has no moving parts. We foresee no problems (economic, technological, etc.) with connecting the SPS to a national power grid because the SPS is a "steady-state" system. The output is predictable. Moreover, a GW class power plant is similar to a nuclear power plant or large hydropower plant. Most of the grid connection issues, therefore, are the same. The SPS is similar to a nuclear power plant in that it provides "base" power to a power grid -- SPS is not intended to meet fluctuating power needs (daily, seasonal, or otherwise). SPS does have some "down time" (seasonal blackouts due to eclipses), but these situations can be compensated with back-up thermal systems.

It is presumed that the SPS is a power source that is put into service in a national power grid (electric power generation and power distribution system). When The SPS becomes "on line," accidents can occur at either the SPS side or the grid side. It is felt that a large power source, such as the SPS, is not really a new situation for power utility companies. The grid is designed to take up the slack if the SPS dropouts without warning. For example, hydropower plants can increase their outputs to compensate for the temporary losses, (for example, by releasing the reserved water). In some cases the output of the rectenna may lapse. However, the DC power converter may be able to handle these lapses in most cases -- within a certain specified range. If the lapse or power failure is too large, then output may cease. If connected to a large national grid, then the grid should be able to take up the slack, somehow. If an accident occurs on the grid side, there is potential for trouble for the rectenna (power source to the grid). The grid may be hit by electrical storms (thunder storms), but the power failure duration should be very short, short enough for the SPS to manage with such hits to the grid. However, a major accident at another power source (resulting output failure for hours or days), may be difficult for the SPS to cope with. More careful studies are needed on this matter.

2.4 SPS Research: State-of-the-Art

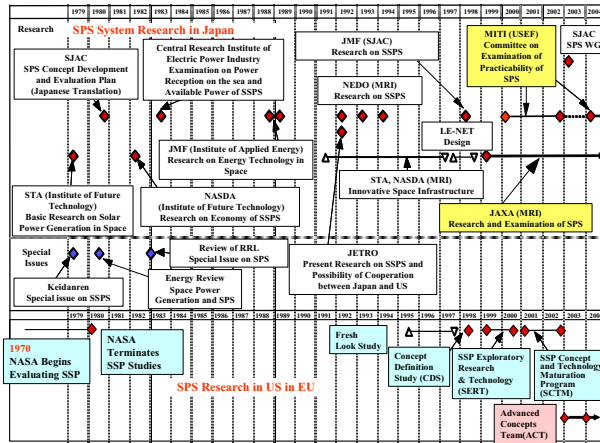

Fig. 2.4.1 Conceptual and Feasibility Studies of SPS in Japan, USA, and Europe through Committee Activities© RISH, Kyoto University

The SPS is the largest application of MPT. In Japan, the USA and Europe, much research on SPS has been and continues to be conducted.

Figure 2.4.1 depicts committee activities on SPS feasibility studies from 1979 to 2004. The activity began in 1979 when a NASA-DOE report was issued. Since then, committee activities to survey the conceptual design and the feasibility of the SPS have continued intermittently up to today.

2.4.1 US Research

2.4.1.1 Initiative

It is widely recognized that the first concept of the SPS was proposed by P. Glaser in 1968⁷⁵ after a series of experiments on Microwave Power Transmission (MPT).⁷⁶ He proposed to put two satellites into geostationary orbit (GEO) so that at least one of them would be illuminated by the Sun at all times. He depicted solar photovoltaic conversion to obtain DC and a klystron traveling-wave amplifier to DC-RF conversion as an example. For solar cells with a diameter of 6km as shown in the figure, about 6GW is obtained if their efficiency is assumed to be 15%.

2.4.1.2 NASA-DOE model⁷⁷

Following Glaser's initiative, the United States conducted an extensive feasibility study in 1978-1980. The feasibility study was a joint effort of NASA and the Department of Energy (DOE). They proposed an improved model known as the NASA-DOE reference model in 1979⁷⁸ shown in Fig. 2.4.2.

In this model, the 50 km² solar array collects approximately 70 GW of Sun's provided energy of 1.37 kW/m² (137 mW/cm²) at GEO and generates 9 GW DC power (13% total efficiency). This system transmits microwave energy of 6.6 GW at 2.45 GHz from a 1km diameter antenna (78% conversion efficiency). The SPS would have 100 million antenna elements for an array antenna with an element spacing of 0.75λ. A 10dB Gaussian taper is assumed for the power distribution in the transmitting antenna in order to obtain better power collection efficiency. A 10 km diameter rectenna ground site at the equator collects 5.8 GW (87% power collection efficiency) and 5GW is sent to the

utility grid. There would be 10 billion rectenna elements with 0.75λ spacing. If the rectenna site is located at 35° latitude, it would be an ellipse of 10 km × 13.2 km with an overall system efficiency of 7%.

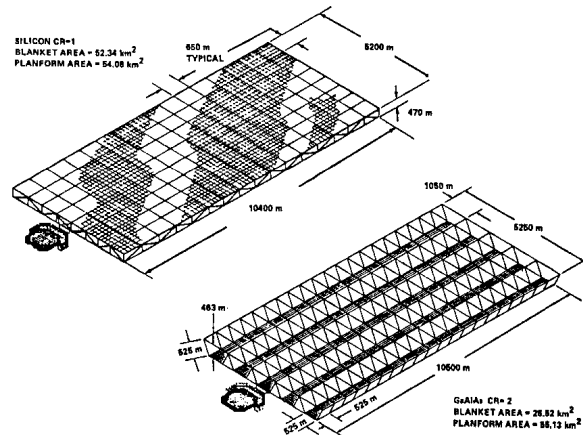

Fig. 2.4.2 NASA-DOE SPS Reference Model

Safety for life on Earth should be taken into account from the view point of electromagnetic compatibility. Power density distribution at the rectenna site is shown in Fig. 2.4.3. Although the power density is 23 mW/cm² at the center, it is just 1 mW/cm² at the edge. The latter satisfies the safety standard and even the former is a quarter of the solar radiation (100 mW/cm²). Note that solar radiation is weaker on the ground than in space because of the atmospheric absorption.

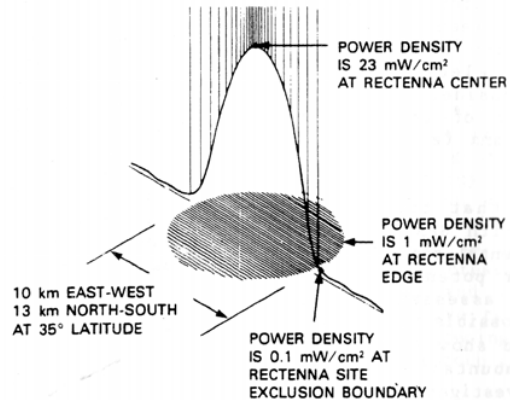

Fig. 2.4.3 Power density distribution at rectenna site on the ground.

The NASA-DOE reference model entailed deploying a series of 60 SPSs into GEO. Each of these SPS was planned to provide dedicated, baseload power ranging from 5 to 10 GW of continuous energy. The platforms were envisioned to be deployed through use of a massive, unique infrastructure. This infrastructure included a fully reusable two-stage-to-orbit (TSTO) Earth-to-orbit (ETO) transportation system as well as a massive construction facility in low Earth orbit (LEO). For the construction, hundreds of astronauts working continuously in space for several decades would have been required. The financial impact of this deployment scheme was significant. In 1996, more than \$250 billion dollars was estimated to be required before the first commercial kilowatt-hour could be delivered.

2.4.1.3 "FRESH LOOK" SSP CONCEPTS

Although the SPS research was suspended in the US in 1980 because of its high cost estimated, it was not abandoned because of its high potentiality as a new power source for the next generation. According to the pre-set policy of re-evaluation of the SPS with an appropriate time interval, the Fresh-Look-SSP (Space Solar Power) concepts have been envisioned from 1997 as an improved SPS reference system.

(1) Sun Tower^{79,80}

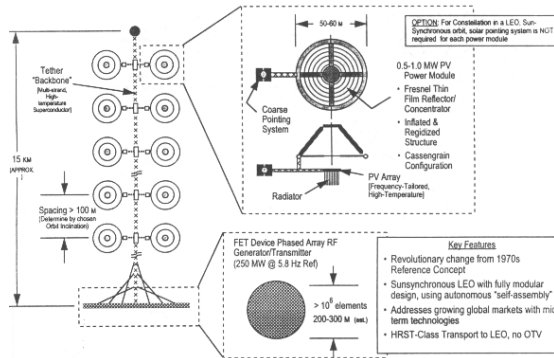

Fig. 2.4.4 The "Sun Tower" SSP Concept (MEO constellation)

The "Sun Tower" SSP Concept is one of the new models and exploits several innovative approaches to reduce the SSP development and life-cycle cost, while at the same time broadening market flexibility. The concept will entail relatively small individual system components with an extensively evolvable modularity as depicted in Fig. 2.4.4. Manufacturing can be 'mass production' style from the first satellite system. Therefore, this system can be developed at a moderate price, ground-tested with no new facilities, and can be demonstrated in a flight environment with a sub-scale test. This system will initially be deployed in low Earth orbit and later migrate to GEO. It is necessary to achieve extremely low launch costs (on the order of \$400 per kg), with payloads of greater than 10 MT; this is consistent with Highly Reusable Space Transportation (HRST) system concepts.

The "Sun Tower" SSP concept is a constellation of medium-scale, gravity gradient-stabilized, and microwave-transmitting space solar power systems as shown in Fig. 3. Each satellite resembles a large, Earth-pointing sunflower in which the face of the flower is the transmitter array, and the 'leaves' on the stalk are solar collectors. The concept is assumed to transmit at 5.8 GHz from an initial operational orbit of 1000 km and operate sun-synchronous at a transmitted microwave power level of about 200 MW. Total beam-steering capability is 60 degrees (+30 degrees). A single transmitting element is, therefore, projected to be a hexagonal surface approximately 5 cm in diameter. These elements are pre-integrated into sub-assemblies for final assembly on orbit. For 200 MW transmitted RF power, the transmitter array is an element and subassembly tiled plane that is essentially circular, approximately 260 meters in total diameter, and 0.5 to 1.0 meters thick.

Sunlight-to-electrical power conversion must be modular and deployable in units 50 to 100 meters in diameter and with a net

1 MW electrical output. The primary technology option is a gossamer-structure based on the reflector with non-dynamic conversion at the focus (e.g., advanced photovoltaics). These sunlight collection systems are presumed to be always sun-facing (with the system in the sun-synchronous orbit) and to be attached regularly in pairs along the length of a structural/power transmitting tether to the backplane of the transmitter array. Heat problems occur both at the surface of the solar cell array and in the transmitter circuit. For both cases, heat rejection for power conversion and conditioning systems is assumed to be modular and integrated with power conversion systems. In the case of the transmitter, heat rejection is assumed to be both modular and integrated at the back-plane of the transmitter array. Power transmission lines from the single central tether attachment point to the backplane are integrated with the modular sub-assemblies of the array.

The nominal ground receiver for the Sun Tower concept is a 4km diameter site with direct electrical feed into the commercial power utilities interface. The space segment is consistent with a variety of ground segment approaches. However, during the early years of operations, multiple ground stations would be required to achieve reasonable utilization of capacity. For primary power, a ground-based energy storage system would be required, in particular in the early phases of overall system deployment in which only a single Sun Tower was operational. A pair consisting of a single satellite and a ground receiver would be sized to a 100 to 400 MW scale, with multiple satellites required to maintain constant power at that level.

(2) Integrated Symmetrical Concentrator⁸¹

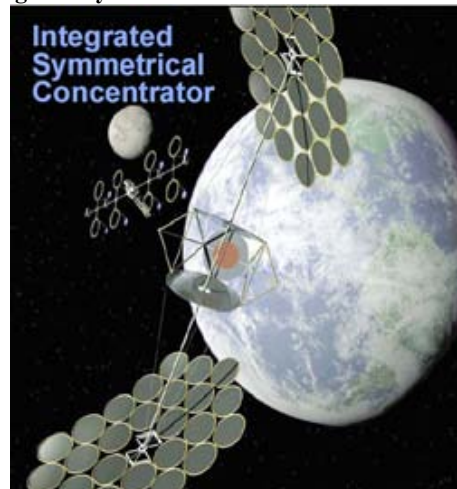

Fig.2.4.5 Integrated Symmetrical Concentrator⁸²

Two clamshell configurations were developed: a 24-mirror version with a 2-to-1 concentration ratio on the solar arrays and a 36-mirror version with a 4-to-1 concentration ratio. Each mirror is planar, approximately 500m in diameter, and is mounted to the back-plane structure at a slightly different angle to form a segmented clamshell primary mirror. Since the Integrated Symmetrical Concentrator (ISC) is not an optical imaging assembly, the light reflected from each mirror only needs to fall somewhere on the PV array, with a goal of minimizing solar array hot spots. The mast length is sized so that the focal length of the mirrors is greater than 10km, which provides a reasonable spot size for the Sun's image on the PV

arrays. With this focal length and a local surface-flatness requirement of about 0.5 degrees on the mirrors, hot spots and excessive light spillage around the PV arrays are minimized. Mirrors on the outer edges of the clamshell, which could experience larger deflections than those located interior to the clamshell, will reflect their energy onto interior regions of the PV array to reduce spillage. An initial ISC concept placed the solar arrays on the back of the transmitter, to minimize power cabling distances. However, the backs of both the solar array and the transmitter need to radiate heat, and thermal radiation estimates of a back-to-back configuration are 90 kW/m^2 . Hence the ISC configurations presented here have two separated solar arrays that are each canted 10 degrees.

2.4.2 Japanese Research

Japanese scientists and engineers started their SPS research in the early 1980s. They conducted a series of MPT experiments including the world's first rocket ionosphere experiment in 1983^{83,84} and experiments on the ground.⁸⁵ They also conducted a series of computer simulations⁸⁶ and theoretical work⁸⁷ following these MPT experiments. After the conceptual study phase, two Japanese organizations recently proposed their own models.

2.4.2.1 JAXA Models

The Japan Aerospace Exploration Agency (JAXA) is studying the SPS conceptual and technical feasibility at different component levels. It is possible to beam the solar energy down to the Earth using either microwave (radio) technology or laser (optical) technology. The microwave method is making especially rapid progress, but the optical methods invariably have weather-related issues. In 2001, JAXA proposed a 5.8GHz 1GW SPS model using microwave technology. Various configurations different from the NASA-DOE model have been proposed, evaluated, and revised.

(1) 2001 Model

In 2001, the first JAXA SPS model was proposed (Fig. 2.4.6). It consists of the following three parts.

Primary Mirror..... $4 \times 6 \text{ km}^2$

Secondary Mirror..... $2 \times 4 \text{ km}^2$

Conversion Module (Sandwich Concept).....2.6 km (diameter)

These three parts are mechanically connected. The Conversion Module is always pointed at the Earth, but the mirrors must rotate and constantly receive solar radiation. This presents immense mechanical engineering challenges.

SPS Conversion Module invariably has two components:

- (1) Solar panel component (Power Generator) and
- (2) Antenna component (Transmitter).

The problem is how to put these two components together. The Sandwich Concept is one solution. In this concept, solar radiation is received on the front side, and microwave energy is radiated from the back side. Some joint modules are required. When this front/back configuration is used, it becomes a very difficult to release heat.

In any event, the Conversion Module has a severe heat dissipation problem. Excessive heat degrades the conversion efficiency of the entire module. In this JAXA model, the estimated distance between the mirror(s) and the Conversion Module is 3 to 4 km. A very large truss is also required.



Fig. 2.4.6 Year 2001 Reference Model⁸⁸

(2) 2002 Model

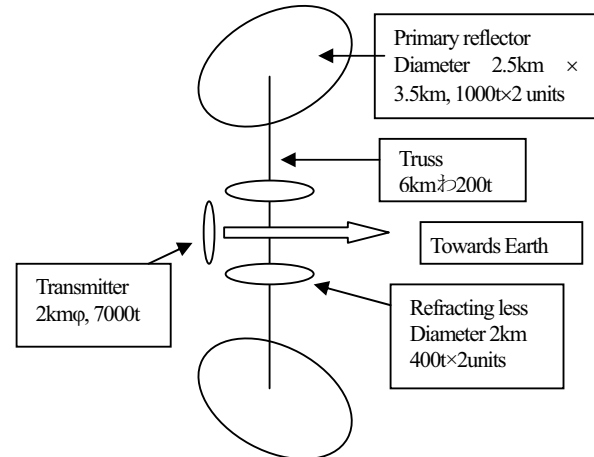

Fig. 2.4.7 Year 2002 Reference Model⁸⁹

The 2002 Model was conceived to solve the main (heat) problems of the 2001 Model. The 2002 Model is depicted in Fig. 2.4.7. The Primary Mirror is 2.5 km x 3.5 km. The truss is 6 km long and weighs 200 tons. The conversion module is 2 km in diameter and weighs 7000 tons. A 400 ton lens is also needed (discussed below). The lens is located between the Primary Mirror and the conversion module. Unfortunately all these components are mechanically connected.

It was suggested that solar reception and microwave transmission should be performed on the same surface (front side). This would free up the back side for heat release. Radiation activity (solar energy reception and microwave transmission) would occur on one side, and unwanted heat would be released from the other side. This is all illustrated in Fig. 2.4.8. As shown in this figure, solar cells and microwave antennas are all on the same surface, that is, aligned side-by-side.

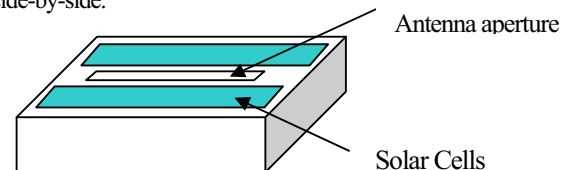

Fig. 2.4.8 Transmitting antenna with solar cells.

As indicated above, the 2002 Conversion Module with solar energy reception and microwave transmission on the same side

is feasible but entails the following issues.

1. It is difficult to match the efficiencies of the solar cell and the microwave generation process. It is hard to find a satisfactory compromise due to large impedance difference.
2. Modularization becomes necessary to transport the system to space. Each module would be as shown in Fig. 2.4.8. Unfortunately, it becomes necessary the need to transmit electric current between modules when the entire SPS System is assembled in space. This interaction between modules eliminates all the advantages of putting everything on the same surface.
3. A complicated refraction lens becomes necessary to direct sunlight from the mirror to the conversion module. This lens would be immensely difficult to design and construct.

Hence, the disadvantages owing to all activities on the same side or same surface outweigh the advantages of this conversion module. We must return to the Sandwich Concept, even though it still has the heat release problem. Some kind of technology breakthrough is needed.

(3) 2003 Model (Formation Flying SPS)⁹⁰

The NASA-DOE Reference Model hinted at the need for a rotating joint. This mechanism becomes necessary because the Primary Mirror and the Conversion Module inherently have different requirements. The Primary Mirror must constantly rotate in three dimensions to accommodate the Sun. It must reflect sunlight to the Conversion Module. However, the Conversion Module that beams energy down to an Earth station cannot be rotated. It was assumed by all SPS developers that the Primary Mirror must be mechanically connected to the Conversion Module.

In 2003, "Formation Flying", a major breakthrough in SPS development, was proposed. In this new proposal, the Primary Mirror is physically separated from the Conversion Module. The 2003 JAXA model is shown in Fig. 2.4.9. It is based on a formation-flight of a rotating mirror system and an integrated panel composed of a photo-voltaic cell surface on one side and a phased array microwave antenna on the other side. The lifting force provided by solar pressure can be used to fly the Primary Mirrors independently. Formation flying mirrors are used to eliminate the need for the rotary joints. The whole system becomes more mechanically stable and reliable.

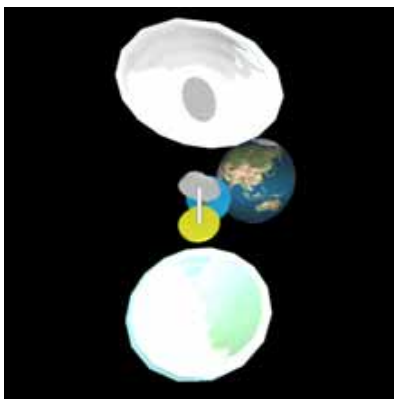

Fig. 2.4.9 Year 2003 Reference Model

The SPS main body will be placed on GEO, and the two

primary mirrors will be placed a few kilometers north / south of the main body. The solar collection mirrors receive solar pressure from the Sun. Since the primary mirrors are tilted against the GEO plane, this solar pressure is divided into the horizontal (parallel to GEO plane) force and the vertical force. The horizontal force should be canceled using some kind of actuators such as the ion thrusters. The remaining vertical force acts as the lifting force that moves the mirrors away from the GEO plane. The mirror also receives the gravitational force caused by the mirror's orbital motion. If the gravitational force is cancelled by the lifting force generated by the solar pressure, then the primary mirrors can stay north / south of the SPS main body, while the primary mirrors are placed on a slightly inclined orbit against GEO. A matter for future studies is how to control the shape and attitude of such light yet huge structures.

2.4.2.2 USEF Model^{91,92}

(1) Design Concept

An SPS with a simple, technically feasible, and practical configuration has been investigated. The Institute for Unmanned Space Experiment Free Flyer (USEF) proposed a simpler model. A study team organized by USEF conducted engineering research for an SPS demonstration experiment using the Japanese launch vehicle H2A.

An artist's concept of the Tethered-SPS is shown in Fig. 2.4.10. The system consists of a large power generation/transmission panel suspended by multi-tether wires from a bus system above the panel. The attitude is automatically stabilized by the gravity gradient force in the tether configuration without any active attitude control. The power generation/transmission panel consists of perfectly equivalent modules, which greatly contributes to the low-cost production, testing, and quality assurance. For the simplest configuration of the power transmission system, the small antenna element and the microwave circuit are integrated as a single entity using Active Integrated Antenna (AIA) technology. Another innovative feature of the module is the cableless interface using a wireless LAN system, which leads to a reliable deployment, integration, and maintenance. The tethered SPS is an assembly of equivalent miniature tethered SPS elements.

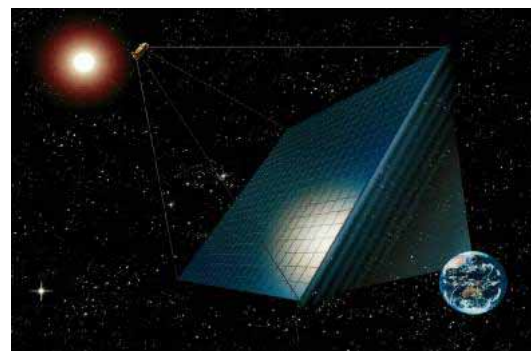

Fig. 2.4.10 Artist's concept of the tethered-SPS

Since this system has no mechanism to track the sun for the power generation, the total power efficiency is 36% lower than that of the NASA-DOE reference model or other sun-pointing types of SPS. However, the simple concept resolves almost all the technical difficulties in previous SPS models. The absence

of a moving structure in a large scale makes this system highly robust and stable. Since a light concentrator is not used for power generation, a large-scale power generation area of km size is required, but the heat generated in the panel can be released into the space without any active thermal control.

From the construction view point, this configuration enables verifying the function of the SPS phase by phase. In most other SPS models, the concept of phased construction steps has not been implemented, but is very important for a large space infrastructure. The miniature tethered element, a part of the commercial SPS, can be used for demonstration experiments in the near future. This strategy provides a scenario for the development from a demonstration model to a commercial SPS

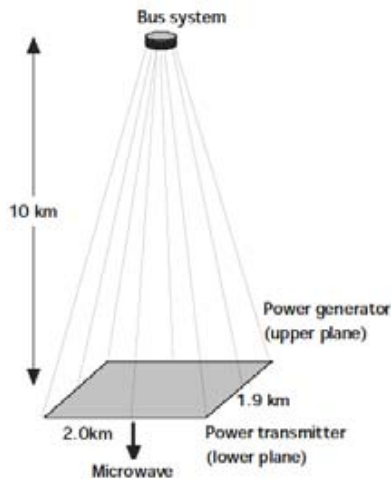

Fig. 2.4.11 1GW class Tethered-SPS

in the technology road map.

(2) Tethered Solar Power Satellite

The SPS proposed by USEF is illustrated in Fig. 2.4.11. This tethered SPS is capable of 1.2 GW power transmission and 0.75 GW average power reception on the ground. It is composed of a power generation and transmission panel of 2.0 km x 1.9 km suspended by multiple-wires deployed from a bus system located 10 km above the power panel. The panel weighs 18,000 tons, and the bus system, 2,000 tons 0.1 m thick. The panel consists of 400 subpanels of 100 m x 95 m. Each subpanel has 9,500 power generation and transmission modules of 1 m x 1 m in area. In each power module, the electric power generated by the solar cells is converted to microwave power and used for other control units. Therefore, there is no power line interface between the modules. The microwave transmitting antennas are on the lower plane. Figure 2.4.12 depicts the concept of the power module. The power module can be realized in the plate configuration with thin film solar cells on both the upper and lower planes and with a planar transmission module including the small antenna and phase controlled magnetron and/or the microwave integrated circuit using Active Integrated Antenna (AIA) technology.

The module contains a power processor, microwave circuits, and their controller. Each module transmits 420 W maximum of microwave power. The power conversion efficiencies for the solar cells and the DC to RF converter are assumed to be 35% and 85%. The module weighs 5 kg and the specific weight of

the module is 12 g/W. These values are two or three times those of the existing technologies for the power conversion efficiencies and approximately 10 times less for the specific weight, but are considered to be realizable in 20 to 30 years.

Fig. 2.4.12 Power module

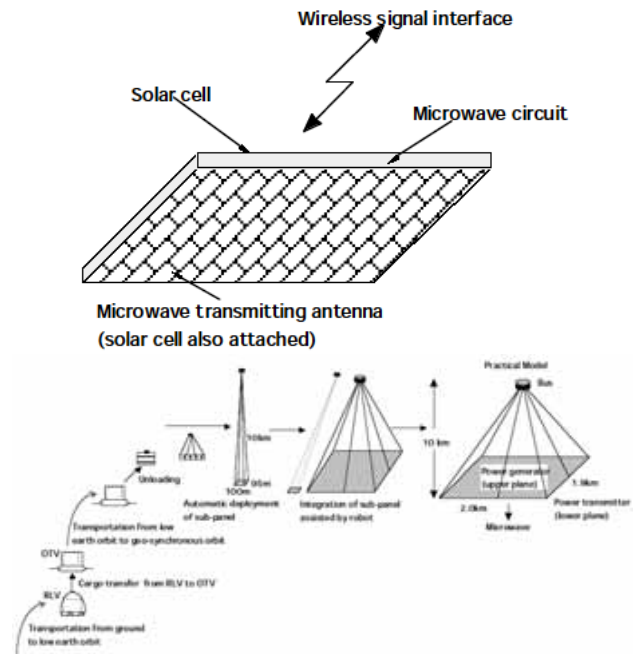

Fig. 2.4.13 Overall construction scenario

There is no wired signal interface between the power modules. The control signal and frequency standard for each module are provided from the bus system by the wireless LAN. The tethered subpanel is composed of a 100 m x 95 m subpanel suspended by four wires connected to a bus system. The 100 m x 95 m 0.1 m thick panel is regarded as a solid panel with the required flatness for phase control in the microwave power transmission. The subpanel consists of 950 structural unit panels of 10 m x 1 m x 0.1 m. The over-all construction scenario is illustrated in Fig. 2.4.13.

The structural unit panels are folded in a package of 9.5 m x 10 m that composes a unit cargo transported from the ground to low earth orbit (LEO) by reusable launch vehicles (RLV). The cargo is transferred to the orbit-transfer vehicle (OTV) in LEO around 500 km and transported to GEO. To avoid the degradation of the solar cells by trapped energetic particles in the radiation belt, the cargo is contained in a radiation shield vessel. If we use a 270 MT OTV equipped with an electric propulsion of 240 N thrust, the cargo is transferred to GEO in two months. The tethered subpanel is deployed automatically in GEO. After the function test of the tethered subpanel is completed, it is integrated to the SPS main body. Docking assistant robots that are manipulated from the ground control center will be required for the integration. This strategy makes it possible to verify the SPS function during the construction phase from the low power to the full power.

2.4.2.3 SPS 2000

The ISAS (Institute of Space and Astronautical Science) solar power satellite working group proposed SPS 2000⁹³ for demonstration of electric power supply to customers at the earliest opportunity. The 10MW model will be launched in a 1000-km equatorial orbit. The SPS 2000 system includes consideration of social, economic, political, legal, public relations⁹⁴ and other non-engineering aspect from the start and was designed in the hope that other organizations will build other satellites of various designs to deliver additional power supplies to the same rectenna. The detail is introduced in Appendix B.2.

2.4.3 European Research

Europeans proposed a Sail Tower SPS^{95,96} (Fig. 2.4.14). The Sail Tower design is similar to NASA's Sun Tower SPS but uses a thin-film technology and innovative deployment mechanisms developed for solar sails. The main characteristics are summarized in Table 2.4.1.

Each single sail is 150m×150m and is automatically deployed by extending four diagonal light-weight carbon fiber (CFRP) booms that are initially rolled up on a central hub. The power generated within the sail modules is transmitted through the central tether to the antenna where microwaves of 2.45 GHz are generated in mass-produced inexpensive magnetrons. Slotted carbon-fiber waveguides mounted on the antenna main structure are used as active antenna elements. As the phased arrays, several sets of wave guides radiate the microwave power to the rectennas on the Earth where the power is transformed and fed into the existing power distribution networks. The power intensity across the antenna surface is designed with a truncated 10 dB Gaussian distribution that minimizes side lobes and scattering.

This technology is much more developed than laser power transmission and promises much higher system efficiencies with almost no weather dependency.



Fig. 2.4.14 Sail Tower.

In 2003, the Advanced Concepts Team (ACT) of the European Space Agency (ESA) initiated a three-phased, multiyear program related to solar power from space. In Europe, terrestrial solar power is one of the fastest growing energy sectors with high growth rates sustained over more than a decade and very promising forecasts. The first phase of the European Program Plan therefore involved the terrestrial research community and was dedicated to assessing the general validity of space concepts for Earth power supply by comparing them with comparable terrestrial solar concepts.^{97,98} In parallel, the general validity of SPS concepts for space exploration and applications were assessed by comparing them with traditional solutions and

nuclear power sources.

Table 2.4.1 Sail Tower Characteristics

European Sail Tower SPS			
Orbit	GEO		
Final # of SPS	1870		
SPS Tower	length	15	[km]
	mass	2140	[mt]
	electricity prod.	450	[MW _e]
Twin module	dim.+tether	150x300x3	[m]
	mass	9	[mt]
	electricity prod.	7.4	[MW _e]
emitting antenna	400 000 magnetron		
	frequency	2.45	[GHz]
	radius	510	[m]
	mass	1600	[mt]
	energy emitted	400	[MW]
receiving antenna site	final number	103	
	antenna size	11x14	
	site including safety zone	27x30	[km]
power delivered	per SPS tower	275	[MW _e]

The first step was taken in August 2002 with the creation of the European Network on Solar Power from Space. It provides a forum for all relevant and interested European players in the field of SPS, including industry, academia and institutions. After the definition of the main aspects of the SPS Programme Plan with its three phases, the activities were done in parallel within studies by the Advanced Concepts Team and by European industrial and academic contractors.^{99,100,101,102}

(1) Integration of Terrestrial Solar Power Expertise

Two parallel industrial studies were undertaken. The two consortia were led by independent energy consultant companies, which coordinated the space as well as terrestrial solar power expertise.

(2) Power Consumption Profile

The scenarios were divided into the provision of base-load power and the provision of peak-load power. For this purpose, the base-load power was defined as the constant provision of the lowest daily demand level. The peak load power was then defined as “non-base-load” power as shown in Fig. 2.4.14, which also gives a typical daily power load profile in Europe over one typical weekday.

(3) Supply Scenarios

Solar power satellites are frequently proposed in the multi-gigawatt range, while terrestrial plants are currently proposed in the several MW range. In order to derive the scaling factors for space and terrestrial solar power plants, different plant sizes ranging from 500 MW_e to 150 GW_e for the peak-load and 500 GW_e for the base-load scenarios have been analysed.

(4) Launch Costs

Launch costs are the single most important parameter in assessing the economic viability of solar power satellites. Any assumption of fixed launch costs would predetermine the outcome of the system comparison studies.

As a consequence, the launch costs were treated as open parameters for these assessments between boundaries given by the current launch cost as upper and the fuel costs as lower limit. In order to overcome the “chicken-egg” problem of the launch frequency required by the construction of SPS reducing the launch costs to values required for the economic construction and operation of SPS, a “learning curve approach” was agreed upon by both consortia. Starting from current launch costs, a 20% reduction was assumed by each doubling of the total launch mass (progress rate of 0.8).

In the first step, space and terrestrial plants were compared by excluding the transportation costs. This comparison and difference of the total costs determine the maximum costs allowed for transportation in the space scenario to remain competitive with terrestrial plants.

In the third step, the progress rate was used to determine the reduction of the launch costs due to the required number of launches of the SPS components for all scenarios. These values were then compared to the required value to become competitive for a certain scenario as determined in step two. The approach did not take into account potential multiplication factors due to possible opening of additional markets created by lower launch costs.

For the base-load power supply scenario, one consortium opted as most likely a system of multiple 220 MWe solar thermal tower units distributed within the south European sunbelt region (including Turkey). The other consortium based the analysis on a solar thermal trough system installed in an unpopulated area in Egypt. Both consortia considered PV plants as higher-cost alternatives with current technology but with large cost reduction potential for the 2020/30 timeframe.

The system of choice for the peak load power supply of one consortium was a highly distributed PV-based scenario, where the amount of unused, potentially available and usable building surfaces were taken into consideration. The other one opted for the same design as for the base-load solar power plant.

Given the restriction to European scenarios, only geostationary space systems were taken into account. While one consortium has opted for wireless power transmission by laser, the other preferred the 5.8 GHz microwave wavelength. Both concepts rely on land-based terrestrial receiver sites (instead of sea-based receivers).

In principle, the first phase was not intended to develop new space solar power station designs, but to rely on the most advanced technical concepts proposed (European Sail Tower concept, the concepts proposed during the NASA Fresh Look and follow-on studies as well as Japanese concepts).^{103,104,105}

Because of limited data on concepts relying on laser power transmission, some further assumptions have been made. The general outline of the laser-based space plant is a geostationary space unit with 111 km² of thin film PV cells augmented by concentrators of the same area. The 20% efficient system generates 53 GWe in orbit, feed into a 50% efficient IR-laser generation system at 1.06 m transmitted with average losses of about 38% essentially due to beam shaping and atmospheric attenuation to an almost 70 km² large PV reception site in North Africa. The ground PV system would have a 20% efficiency for direct sunlight but a 52% conversion efficiency for the IR-laser beam. Adding additional 4% collection losses in space and 4% losses on

ground, the space segment would deliver a constant supply of 7.9 GWe to the terrestrial power grid.

The comparison results are presented below.

(1) Base-load Power Supply

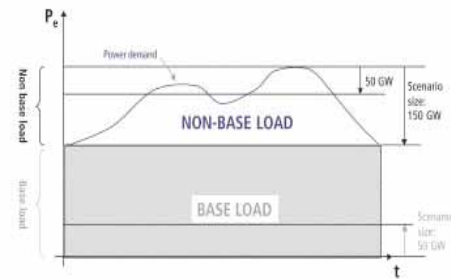

Fig. 2.4.15 Definition of base- and peak-load (non-baseload) power as used for the present assessment.

In the case of base-load scenarios, terrestrial solar tower plants with local hydrogen storage capacities promise electricity generation costs between 9 €/cent/kWh for the smallest (500 MWe) and 7.6 €/cent/kWh for the largest (500 GWe) plants.

Under those conditions, the SPS would not be competitive with the smallest scenarios even without any launch costs. For the 5 GWe and larger scenarios, the launch costs between 620 and 770 €/kg are required for the SPS to be competitive with terrestrial plants. In case local pumped hydrostorage facilities are available, the required launch costs would be significantly lower, dropping to roughly one third of these values.

(2) Non base-load Power Supply

For non-base-load scenarios, solar tower plants with local hydrogen storage capacities have generation costs between 10 €/kWh for the smallest scenarios to 53 €/cent/kWh for the largest (150 GWe) plants. Solar power satellites reach potentially competitive electricity generation costs only above relatively large plant sizes of about 50 GWe.

For the 50 GWe and higher scenarios, launch costs between 155 and 1615 €/kg would be required for SPS to reach a competitive level with terrestrial plants. If locally pumped hydrostorage facilities are available, the required transport costs would be lowered by about a factor two.

(3) Energy payback times - primary validity

Space as well as terrestrial solar power plant concepts have been “accused” of violating the fundamental law of every power plant: generating more energy than necessary for their proper construction. It was therefore important to assess the exact cumulated energy demand (CED) of the systems and compare it with the energy output over their lifetime. The resulting energy payback time provides a measure for the validity of the concepts as power plants.

There are several methods to assess the cumulated energy demand of any system. The fast but most imprecise method is an energetical input/output analysis. This method was already partially applied to SPS systems in the past, in part based on energy estimates derived from material costs, assuming a reliable €-Joule relationship. If all the components are known, a material balance analysis can be made, combining the masses of all components with their specific energy demands obtained from specialized databases.

The European analysis relies on a complete material flow analysis, the most precise method to determine the CED. For some parts of the space system for which the data for the exact material flow analysis were not available, the method of material balance was used, partially based on CEDs provided by specialized databases.

In all considered cases, the energy payback times for space and terrestrial solar power plants were shorter than or equal to one year. For the Egypt-based terrestrial system, the energy payback times seem to be slightly higher than for the distributed system in the European solar belt. In both cases, from a purely energetic point, solar power satellites promise a slightly shorter energy payback time, ranging from 4 months to 2 years depending on the size and the concept (all including the launchers).

It should be noted that while using slightly different methods and different space concepts, the assessments by the two independent consortia for the space segments derive almost the same values (3.9 to 4.8 months) despite their different transmission technologies. The terrestrial scenario based on solar thermal tower plants (local hydrogen storage) in south Europe leads to energy payback times of 8.4 months, the solar thermal trough case (with pumped hydroelectric storage) in North Africa has a calculated payback time of 8.1 to 8.9 months. The energy payback times for the terrestrial photovoltaic case in north Africa are expected to fall from about 31 months with advanced current technology to 8.3 months based on 2030 PV technology.

The detailed assessments have shown that both space and terrestrial solar plants have extremely short energy payback times and are, from a purely energetic point of view, attractive power generators.

ESA will start the second phase of the European SPS Programme Plan in late 2005/ early 2006, expected to provide advanced results concerning the integration of space and terrestrial solar power plant concepts and laser power transmission techniques.

2.4.4 Worldwide Activities

As world-wide activities, the SPS research groups have initiated international collaboration such as Japan-US SPS workshop,¹⁰⁶ International Conference on SPS and WPT,¹⁰⁷ International Astronautical Congress (IAC) Space Power Committee,¹⁰⁸ and URSI inter-commission working group.

¹ Insolation examples: 5.0 (Cairo, Egypt), 4.8 (Austin, Texas, USA), 4.52 (Sydney, Australia), 3.71 (Rome, Italy), 3.25 (Kagoshima, Japan), 3.83 (Madrid, Spain).

² G. Maral and M. Bousquet, *Satellite communications systems*, 3rd Ed., John Wiley & Sons, 1993.

³ H. Hayami, M. Nakamura, and K. Yoshioka, *The Life Cycle CO₂!* Emission Performance of the DOE/NASA Solar Power Satellite system: A Comparison of Alternative Power Generation Systems in Japan, IEEE Trans. Systems, Man, and Cybernetics - Part C: Applications and Reviews, vol. 35, no. 3, 391-400, 2005.

⁴ F. R. Shapiro, *Utilities in the sky?*, ReFocus, 54-57, Nov./Dec., 2002.

⁵ Incoming solar radiation.

⁶ J. K. Strickland, *Solar Energy*, Vol. 56, No.1, 23-40, 1996. See also, J. K. Strickland, in P. Glaser, et al. (eds.), *Solar Power Satellites: A Space Energy System for Earth*, pp.133-205, England: Praxis, 1998.

⁷ B. Olsen, December 3, 1998, Computer Lab, Cecil Community College, North East, Maryland, USA, <http://clab.cecil.cc.md.us/faculty/biology1/Solar%20power%20Satellites.s.HTM>

⁸ http://redec.nrel.gov/solar/old_data/nsrdb/redbook/atlas/serve.cgi

⁹ Arthur Smith, April 2004 issues of *Physics and Society Newsletters* published by the American Physical Society (<http://www.aps.org/units/fps/newsletters/>).

¹⁰ Fetter, S., *Space Solar Power: An Idea whose Time will never come?* *Physics and Society*, 33, 1, 10-11, 2004

¹¹ Smith, Arthur, *Physice and Society*, April 2004, Web Issue, <http://www.aps.org/units/fps/newsletters/2004/april/article2.cfm>

¹² DOE and NASA report; "Satellite Power System; Concept Development and Evaluation Program", Reference System Report, Oct. 1978! (Published Jan. 1979).

¹³ NEDO (New Energy Development Organization) /MRI (Mitsubishi Research Institute), Ministry of Trade and Industry, Research of SPS System (in Japanese), 1992, 1993, and 1994.

¹⁴ http://www.aerospace.nasa.gov/library/event_archives/home&home/glenr/invasp/sld003.htm

¹⁵ <http://space-power.grc.nasa.gov/ppo/sctm/11>

¹⁶ Kuminaka, H., K. Nishiyama, Y. Shimizu and K. Toki, "Deep Space Maneuver by Microwave Discharge Ion Engine (in Japanese)", Proc. of the 6th SPS symposium, pp.39-44, 2003

¹⁷ Utashima, M., "In-Orbit Transportation of SSPS Considering Debris and Cell Degradation by Radiation (in Japanese)", Proc. of 47th Space Sciences and Technology Conference, pp.662-667, 2003

¹⁸ $\text{=(number density of atom)} \times (\text{satellite velocity}) \times (\text{time interval})$

¹⁹ M. Izumitani, et al., Results of flight demonstration of terrestrial solar cells in space, *Progress in Photovoltaics: Research and Applications*, 13, pp. 93-102, 2005.

²⁰ m_{req} is defined as the mass of the SPS on GEO that produces a power of 1GW on the ground with no cell degradation. m_{req} is currently estimated to be about 10 thousand tons.

²¹ Air mass zero, or extraterrestrial spectrum.

²² Kushiya, K., Proc. of 3rd World Conference on Photovoltaic Energy Conversion, CD:2PL-C1-02, 2003

²³ Kawakita, S., M. Imaizumi, S. Matsuda, K. Kushiya, T. Ohshima, A. Ohi, and T. Kamiya, Proc. of 3rd World Conference on Photovoltaic Energy Conversion, CD:3P-B5-11, 2003

²⁴ Imaizumi, M., K. Tanaka, S. Kawakita, T. Sumita, H., Naito, and S. Kuwajima, "Study on Power Generation System for a Space Photovoltaic Power Satellite", Proc. of 48th Space Sciences and Technology Conference, pp.111-115, 2004

²⁵ A.K.Misra & J.D.Whittenberger, Proc. 22nd IECEC, 188, IEEE, 1987.

²⁶ L.M.Sedgwick, K.J.Kauman, K.L.McLallin & T.W.Kerslake, Proc. 26th IECEC, 262, IEEE, 1991..

²⁷ R.K.Shaltens, L.S.Mason, Proc..31th IECEC, Washington, D.C., 1996, Vol.2 p.660, IEEE, 1996.

²⁸ "Advanced Solar Dynamic Technology", Glenn Research Center, http://www.grc.nasa.gov/WWW/tmsb/dynamicpower/doc/adv_sd_tech.html

²⁹ G.Johnson, M.E.Hunt, W.R.Determan, A.Hosang, J.Ivanenok, M.Schuller, "Design and Integration of a Solar AMTEC Power System with an Advanced Global Positioning Satellite", Proc. 31th IECEC, Vol.1, Washington, D.C., 1996, P623, IEEE, 1996.

³⁰ R.V.Boyle, M.G.Coombs, C.T.Kudiyar: "Solar Dynamic Power Option for the Space Station", Proc. 23rd IECEC, Vol.3, Jul. Aug. 1988, Denver, Colorado, p.319, the American Society of Mechanical Engineers, 1988.

³¹ A.Y.Ender, et al., "Cascade Space Solar Power System with High Temperature Cs-Ba Thermionic Converter and AMTEC", Proc.. STAIF,

p.1565, 1998.

³² H. Kawasaki, S. Toyama, and M. Mori, "Thermal Control System for Space Solar Power System", Proc. of the 47th Space Sciences and Technology Conference, pp.67-70, 2003 (in Japanese)

³³ Study on Space Solar Power Systems, JAXA Contractor Report (in Japanese), 2004.

³⁴ Kimbara, "Membrane, its function and applications," p. 109, Japanese Standards Association, 1991. (In Japanese)

³⁵ Research and Study of SSPS (Space Solar Power System) (in Japanese), NASDA/MRI, Science and Technology Agency, 1999

³⁶ Study on Space Solar Power Systems, JAXA Contractor Report (in Japanese), 2001.

³⁷ Mitani, T., N. Shinohara, H. Matsumoto, and K. Hashimoto, "Experimental Study on Oscillation Characteristics of Magnetron after Turning off Filament Current", Electronics and Communications in Japan, Part II : Electronics., Vol. E86, No. 5, 2003, pp.1-9

³⁸ Brown, W. C., The SPS transmitter designed around the magnetron directional amplifier, Space Power, vol.7, no.1, pp.37-49, 1988.

³⁹ Shinohara, N., J. Fujiwara, and H. Matsumoto, Development of Active Phased Array with Phase-controlled Magnetrons, Proc. ISAP2000, Fukuoka, vol.2, pp.713-716, 2000.

⁴⁰ Shinohara, N., and H. Matsumoto, "Phased Array Technology with Phase and Amplitude Controlled Magnetron for Microwave Power Transmission", Proc. of the 4th Int. Conf. on Solar Power from Space - SPS '04., pp.117-124, 2004

⁴¹ Shinohara, N., H. Matsumoto, and K. Hashimoto, "Phase-Controlled Magnetron Development for SPORTS : Space Power Radio Transmission System", The Radio Science Bulletin, No.310, pp.29-35, Sep. 2004

⁴² Fujiwara, E., Y. Takahashi, N. Tanaka, K. Saga, K. Tsujimoto, N. Shinohara, and H. Matsumoto, "Compact Microwave Energy Transmitter (COMET)", Proc. of Japan-US Joint Workshop on SSPS (JUSPS), pp.183-185, 2003

⁴³ V. L. Granatstein, P. K. Parker, and C. M. Armstrong, "Scanning the Technology: Vacuum Electronics at the Dawn of the Twenty-First Century," *Proc. IEEE*, vol. 87, pp. 702-716, May 1999

⁴⁴ Bosch, E., P. Y. Cabaud, and B. Cotteau, "Industrial Program GEN 2000 from TTE Improved Ku-Band TWT with Efficiency More Than 70% Efficiency", AIAA2000-1160, pp.613-618, Apr. 2000.

⁴⁵ Katakami, K., "Review of Performance Improvement and Development Trends (in Japanese)", Tech. Report of IEICE, SPS2003-03(2004-02), pp.15-22, 2004

⁴⁶ S. Kitazawa, Commercialization of the on-Board Equipments for Communications Satellites in Japan, Proc. of MWE'96 Microwave Workshop Digest[WS14-3], pp.387-395, 1996

⁴⁷ M. Skolnik, Radar Handbook, 2nd Ed., McGraw-Hill, 1990.

⁴⁸ S. Ogura, A. Kiyohara, K. Abe, T. Ohshima, T. Ono, K. Seino, H. Hirose, Development of 60W C-band solid State Power Amplifier for Satellite Use, 19th AIAA International Communications Satellite Systems Conference, AIAA-2001-0103, 2001.

⁴⁹ Ishii, K., T. Okamoto, H. Maeda, H. Ishida, and M. Shigaki, Characteristics of a high power and high efficient solid state power amplifier for 2.5 GHz band mobile communication satellites, Tech. Rept. IEICE, AP94-47, 53-59, 1994.

⁵⁰ SPS 2000 Concept Design Documents (in Japanese), S2-I1-X, ISAS, 1993.

⁵¹ Hikage, T., K. Munakata, T. Nojima, M. Omiya, and K. Itoh, Cavity-Backed Slot Antennas and Arrays with Simple Geometry Adapted to Microwave The Radio Science Bulletin, No.310, pp.23-28, Sep. 2004

⁵² Research of SPS System (in Japanese), NEDO (New Energy Development Organization) /MRI (Mitsubishi Research Institute), Ministry of Trade and Industry, 1992, 1993, and 1994.

⁵³ Takano, T., N. Kamo, and A. Sugawara, Simplification of an array antenna by reducing the fed elements, Trans. Institute of Electronics, IEICE, vol. E88-B, No. 9, pp. 421-424, 2005.

⁵⁴ Murao, Y. and T. Takano, Proposal and analysis of ultra-large aperture array antennas (in Japanese), Trans. IEICE, vol.J80-B-1, No. 6, pp. 501-506, 1997.

⁵⁵ Miyamoto, R. Y., and T. Itoh, "Retrodirective arrays for wireless communications", IEEE Microwave Magazine, vol. 3, pp. 71-79, Mar. 2002.

⁵⁶ Sung et al., IEEE Topical Conference on Wireless Communication Technology, 2003, pp. 220 - 221, Hawaii, U.S.A., 15-17, Oct. 2003

⁵⁷ Van Atta, L. G., "Electromagnetic Reflector", U. S. patent No. 2,908,002; Oct. 6, 1959.

⁵⁸ Leong, K. M. H., R. Y. Miyamoto, and T. Itoh, "Ongoing Retrodirective Array Research at UCLA", . Tech. Report of IEICE, SPS2002-08(2002-11), pp.15-20, 2002

⁵⁹ Matsumoto, H., N. Shinohara, and K. Hashimoto, "Activities of Study of Solar Power Satellite/Station (SPS) in RASC of Kyoto University (in Japanese)", Tech. Report of IEICE, SPS2002-07(2002-11), pp.9-14, 2002

⁶⁰ Mikami, I., T. Mizuno, H. Ikematsu, H. Satoh, H. Matsumoto, N. Shinohara, and K. Hashimoto, "Some Proposals for the SSPS Actualization from Innovative Component Technology Standpoint", Proc. of URSI EMTS 2004, pp.317-319, 2004

⁶¹ Hashimoto, K., K. Tsutsumi, H. Matsumoto, and N. Shinohara, "Space Solar Power System Beam Control with Spread Spectrum Pilot Signals", The Radio Science Bulletin, No.311, pp. 31-37, 2004

⁶² Little, F. E., S. J. Kokel, C. T. Rodenbeck, K. Chang, G. D., Arndt, and P. H. Ngo, "Development of Retrodirective Control Transmitter for Wireless Power Transmission", The Radio Science Bulletin, No.311, pp. 38-46, 2004

⁶³ Tominaga, M., K. Morishita, T. Nakada, and USEF SSPS Study Team, "Phase Synchronous System of Separated Units", Proc. of the 4th Int. Conf. on Solar Power from Space - SPS '04., pp.139-144, 2004

⁶⁴ Hashimoto, K., H. Shibata, and H. Matsumoto, "A Self-Steering Array and Its Application to Phase Synchronization of transmitter units and SSPS (in Japanese)", Tech. Report of IEICE, SPS2004-06(2005-01), pp.5-10, 2005

⁶⁵ Research and Study of SSPS (Space Solar Power System) (in Japanese), JAXA/MRI, Science and Technology Agency, 2005

⁶⁶ Brown, W. C., "The History of the Development of the Rectenna", Proc. Of SPS microwave systems workshop, pp.271-280, Jan. 15-18, 1980, at JSC-NASA

⁶⁷ Gutmann, R. J. and J. M. Rorrego, "Power Combining in an Array of Microwave Power Rectifiers", IEEE Trans. MTT, Vol.MTT-27, No.12, pp.958-968, 1979.

⁶⁸ Yoo, T-W., and K. Chang, Theoretical and experimental development of 10 and 35 GHz Rectennas, IEEE Trans., MTT-40, 1259-1266, 1992.

⁶⁹ Shinohara, N. and H. Matsumoto, "Experimental Study of Large Rectenna Array for Microwave Energy Transmission", IEEE-MTT, Vol.46, No.3, pp.261-268, 1998

⁷⁰ Miura, T., N. Shinohara, and H. Matsumoto, "Experimental Study of Rectenna Connection for Microwave Power Transmission", Electronics and Communications in Japan, Part 2, Vol. 84, No.2, pp.27-36, 2001

- ⁷¹ Brown, W. C., "The History of Power Transmission by Radio Waves, IEEE Trans. MTT, Vol. 32, No. 9, pp.1230-1242, 1984
- ⁷² M. Shimokura, N. Kaya, N. Shinohara, and H. Matsumoto, Point-to-point microwave power transmission experiment, Trans. Institute of Electric Engineers Japan, vol.116-B, no.6, pp.648-653, 1996 (in Japanese).
- ⁷³ Matsumoto, H., K. Hashimoto, N. Shinohara, and T. Mitani, "Experimental Equipments for Microwave Power Transmission in Kyoto University", Proc. of the 4th Int. Conf. on Solar Power from Space - SPS '04,, pp.131-138, 2004
- ⁷⁴ Fujino, Y., M. Fujita, N. Kaya, S. Kunimi, M. Ishii, N. Ogihata, N. Kusaka, and S. Ida, "A Dual Polarization Microwave Power Transmission System for Microwave propelled Airship Experiment", Proc. of ISAP'96, Vol.2, pp.393-396, 1996.
- ⁷⁵ P. Glaser, Power from the Sun: Its future, *Science*, Vol. 162, 22 Nov. 1968.
- ⁷⁶ Refer to W. C. Brown, The history of power transmission by radio waves, IEEE Trans. Microwave Theory and Techniques, MTT-32, pp.1230-1242, 1984.
- ⁷⁷ Based on Introduction section of John C. Mankins, http://spacefuture.com/archive/a_fresh_look_at_space_solar_power_new_architectures_concepts_and_technologies.shtml
- ⁷⁸ US Department of Energy and NASA; Satellite Power System; Concept Development and Evaluation Program, Reference System Report, Oct. 1978 (Published Jan. 1979).
- ⁷⁹ J. C. Mankins, A fresh look at space solar power: New architectures, concepts and technologies, *Acta Astronautica*, Vol. 41, Nos. 4-10, 347-359, 1997.
- ⁸⁰ J. O. McSpadden and J. C. Mankins, Summary of recent results from NASA's Space Solar Power (SSP) Programs and the current capabilities of microwave WPT technology, *IEEE Microwave Magazine*, vol. 3, no. 4, 46-57, December, 2002.
- ⁸¹ C. Carrington and K. Feingold, Space solar power concepts: demonstrations to pilot plants, IAC-02-R.P.12, IAC, 2002 ; cited with permission of the American Institute of Aeronautics and Astronautics, Inc.
- ⁸² J. C. Mankins, Space Solar Power (SSP) New Energy Options for the 21ST Century Overview and Introduction Overview and Introduction, SCTM project, <http://space-power.grc.nasa.gov/ppo/sctm/11>
- ⁸³ H. Matsumoto, N. Kaya, I. Kimura, S. Miyatake, M. Nagatomo, and T. Obayashi, MINIX Project toward the Solar Power Satellite—Rocket experiment of microwave energy transmission and associated nonlinear plasma physics in the ionosphere, ISAS Space Energy Symposium, 69-76, 1982.
- ⁸⁴ N. Kaya, H. Matsumoto and R. Akiba, Rocket Experiment METS Microwave Energy Transmission in Space, *Space Power*, vol.11, no.3&4, pp.267-274, 1992.
- ⁸⁵ M. Shimokura, N. Kaya, N. Shinohara, and H. Matsumoto, Point-to-point microwave power transmission experiment, Trans. Institute of Electric Engineers Japan, vol.116-B, no.6, pp.648-653, 1996 (in Japanese).
- ⁸⁶ H. Matsumoto, and T. Kimura, Nonlinear excitation of electron cyclotron waves by a monochromatic strong microwave: Computer simulation analysis of the MINIX results, *Space Power*, vol.6, 187-191, 1986.
- ⁸⁷ H. Matsumoto, Numerical estimation of SPS microwave impact on ionospheric environment, *Acta Astronautica*, 9, 493-497, 1982.
- ⁸⁸ Study on Space Solar Power Systems, JAXA Contractor Report (in Japanese), 2002.
- ⁸⁹ Study on Space Solar Power Systems, JAXA Contractor Report (in Japanese), 2003.
- ⁹⁰ Mitsushige Oda, Realization of the Solar Power Satellite Using the Formation Flying Solar Reflector, NASA Formation Flying symposium, Washington DC, Sept.14-16, 2004.
- ⁹¹ Sasaki, S., K. Tanaka, S. Kawasaki, N. Shinohara, K. Higuchi, N. Okuizumi, K. Senda, K. Ishimura, and USEF SPS Study Team, "Conceptual Study of SPS Demonstration Experiment", *The Radio Science Bulletin*, No.310, 2004, pp.9-14
- ⁹² Y. Kobayashi, T. Saito, K. Ijichi, and H. Kanai, Proc. of the 4th Int. Conf. on Solar Power from Space - SPS '04, July 2004, Granada, Spain (ESA SP-567, December 2004)
- ⁹³ M Nagatomo and K Itoh, "An Evolutionary Satellite Power System for International Demonstration in Developing Nations", *Proceedings of SPS91*, pp 356-363; 1991 also at http://www.spacefuture.com/archive/an_evolutionary_satellite_power_system_for_international_demonstration_in_developing_nations.shtml
- ⁹⁴ H Matsuoka & P Collins, "Benefits of International Cooperation in a Low Equatorial Orbit SPS Pilot Plant Demonstrator Project", *Proceedings of SPS '04, Esa SP-567*, pp 213-217, 2004; also at http://www.spacefuture.com/archive/benefits_of_international_cooperation_in_a_low_equatorial_orbit_sps_pilot_plant_demonstrator_project.shtml
- ⁹⁵ W. Seboldt, M. Klimke M. Leipold N. Hanowski, European Sail Tower SPS Concept, *Acta Astronautica*, Vol 48. No. 5-12. pp. 785-792. 2001.
- ⁹⁶ <http://www.esa.int/gsp/ACT/doc/ACT-RPR-2200-LS-0211-Kobe02%20Solar%20Power%20Satellites%20-%20European%20approach.pdf>
- ⁹⁷ L. Summerer, F. Ongaro, M. Vasile, and A. Gálvez. Prospects for Space Solar Power Work in Europe. *Acta Astronautica*, 53:571–575, 2003.
- ⁹⁸ ESA - Advanced Concepts Team. Advanced Power Systems. website. <http://www.esa.int/act>, (acc. June 04).
- ⁹⁹ L. Summerer, M. Vasile, R. Biesbroek, and F. Ongaro. Space and Ground Based Large Scale Solar Power Plants – European Perspective. *IAC-03/R.1.09*, 2003
- ¹⁰⁰ L. Summerer and G Pignolet. SPS European Views: Environment and Health. *URSI*, 2003..
- ¹⁰¹ L. Summerer. Space and Terrestrial Solar Power Sources for Large-scale Hydrogen Production. In Marini, editor, *Hypothesis V*, pages 233–258, 2003.
- ¹⁰² L. Summerer. Space and Terrestrial Solar Power Sources for Large-Scale Hydrogen Production - A Comparison. In *HyForum 2004*, Beijing, China, Mai 2004.
- ¹⁰³ J. Mankins et al., Space solar power - A fresh look at the feasibility of generating solar power in space for use on Earth. Technical Report SIAC-97/1005, NASA, SAIC, Futron Corp., April 1997
- ¹⁰⁴ N. Kaya. A new concept of SPS with a power generator/transmitter of a sandwich structure and a large solar collector. *Space Energy and Transportation*, 1(3):205, 1996.
- ¹⁰⁵ C. Cougnet, E. Sein, A. Celeste, and L. Summerer. Solar power satellites for space exploration and applications. In ESA, editor, *SPS'04 Conference - Solar Power from Space*, Granada, Spain, June 30 - July 2 2004.
- ¹⁰⁶ Special section on SSPS, *Radio Science Bulletin*, Nos. 310 and 311, 2004.
- ¹⁰⁷ Proc. of the 4th Int. Conf. on Solar Power from Space - SPS '04, July 2004, Granada, Spain (ESA SP-567, December 2004)
- ¹⁰⁸ http://www.iafastro.com/feder/structures/Tech_Committees/Com_Power.htm

Chapter 3 SPS Radio Technologies

This chapter describes the present and future research on SPS-related technologies. Microwave power transmission (MPT), including beam control, microwave devices, rectennas, measurements, and spin-off technologies are described. Influences of SPS and scientific topics are treated in Chapter 4. Antenna and power transmission technologies applied to SPS are basically extensions of conventional array antenna systems. There exist, however, some essential and important differences, which are itemized below.

- 1) For microwave power transmission (MPT), highly efficient energy transmission between the transmitter and the receiver antennas is required. The product of the transmitter and receiver diameters is a key parameter.¹ A huge array is necessary for high efficiency. The diameters are on the order of kilometers and the number of their elements is on the order of billions for the SPS. The efficiency is about 90%.
- 2) Radiation in an unwanted direction at an angle from the main beam is called a sidelobe. Sidelobes, which are also called grating lobes, are equal in amplitude to the main beam if the element spacing exceeds one wavelength in a uniform linear array. Suppression of grating lobes and sidelobes is necessary for safety and in order to avoid interference with communications. Tapering of the output power distribution or its equivalent in the transmitter antenna array is one way to decrease sidelobes and increase the transmission efficiency. However, this makes the antenna and power transmission system complex.
- 3) The microwave beam should be correctly directed to the rectenna site. Pointing accuracy 300 m or less from GEO (36,000 km in altitude) is required for the a rectenna diameter of a few to several kilometers. This corresponds to 0.0005°.
- 4) It is desirable to decrease the number of phase shifters as they cause extra losses and are expensive. It is also important to decrease the number of power dividers in the case of vacuum tube transmitters for the same reasons.
- 5) Highly efficient and light weight power transmitters with low harmonics need to be developed. The low weight to power ratio is important for decreasing the launch cost. The microwave devices for the SPS power transmitters are either semiconductor devices or microwave tubes.
- 6) Received power densities are not constant over the rectenna site. Rectennas that are highly efficient under various input power conditions must be developed. Connection of the rectenna output to the existing power network is another important issue.
- 7) Measurement and calibration of the huge antennas are essential.

The aperture of a transmitting antenna array of a typical 1 GW SPS is 1 to 2 km in diameter. The average microwave power density at the SPS array will be 1 kW/m². If we use 2.45 GHz (5.8 GHz) for the MPT, the number of antenna elements per square meter is of the order of 100 (400). Therefore, the power allotted to each element is of the order of 10 or 2.5 W/element. The output powers for typical models under the 10-dB Gaussian taper are shown in Table 2.3.2.

3.1 Microwave Power Transmission Technology

How much energy transmitted from the geostationary earth orbit can be received on the ground? Basically almost all the energy can be collected on the ground through the microwave power transmission (MPT). The transmission efficiency of the energy is about 90% in typical SPS designs. MPT characteristics are described below.

3.1.1 Use of EM waves to transmit energy

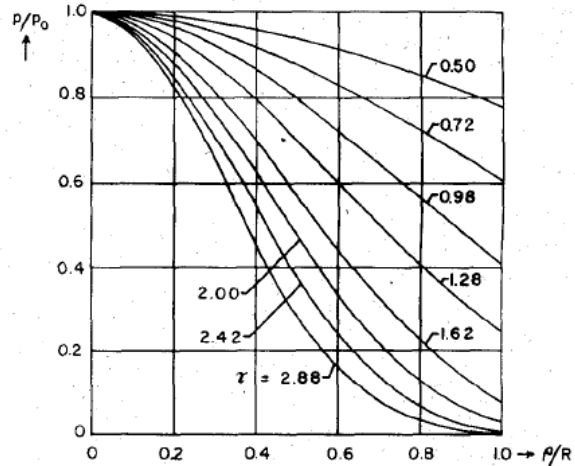

Fig. 3.1.1 Transmission efficiency as a function of parameter τ for optimum power density distribution across the transmitting antenna aperture as shown in Fig. 3.1.2^{1,2}

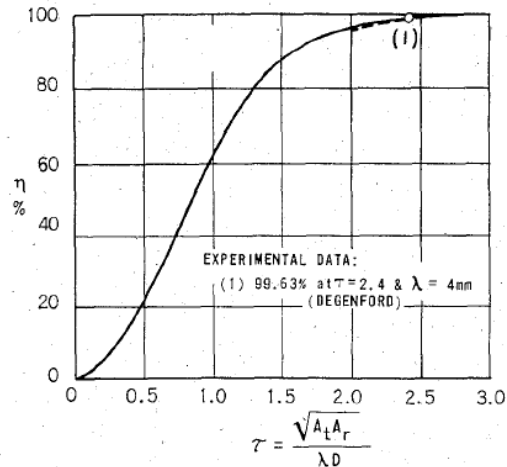

Fig. 3.1.2 Relative cross-section power density distribution across the transmitting and receiving antenna apertures for various values of τ as given in Fig. 3.1.1. R is the radius of the transmitting or collecting antenna and ρ is the radial distance from the center. The field at the collector extends beyond its edges.^{1,2}

Following the basic concept derived by Goubau and Schwering,³ Brown¹ showed that the power transmission efficiency can approach 100% if parameter $\tau = A/(\lambda D)$ is larger than 2 and the distributions on the aperture are Gaussian, where A is the geometric mean of the transmitter and receiver aperture areas (A_t and A_r), λ is the wavelength, and D is the separation

distance between the two apertures. For example, the efficiency is 99.63% at $\tau = 2.4$ as shown in Fig. 3.1.1. This can be attained if both diameters of the apertures, d_t and d_r , λ , and D are 1.4km, 4km, 5.17cm (5.8GHz), and 36,000 km, respectively. If $d_t = 1$ km as shown in the previous chapter instead of $d_t = 1.4$ km, then $\tau = 1.7$. High efficiency is obtained when the power density distribution over the apertures is close to Gaussian as shown in Fig. 3.1.2.

3.1.2 Application of Friis Transmission Equation

The conclusion in the previous subsection is contrary to the general belief that the power density falls off as the square of the distance. The Friis Transmission Equation can be written as

$$\frac{P_r}{P_t} = \frac{A_t A_r}{\lambda^2 D^2} = \tau^2 \quad (3.1.1)$$

where P_r and P_t are the receiving and transmitting powers, respectively. In the case of the previous subsection, the receiving power is larger than the transmitting power since $\tau > 1$. This unrealistic situation occurs because $D < 2d_t^2/\lambda$, that is, in the near field or Fresnel zone.⁴ It should be noted that the received power density is not constant and has a distribution with a maximum at its center as shown in Fig. 2.2.1 even in this geostationary distance. The Friis transmission equation is not applicable. In a case of communications, for example, parameters for a Japanese broadcasting satellite, $d_t = 0.73$ m, $d_r = 0.37$ m, $\lambda = 0.025$ m, and $D = 3600$ km, then $\tau = 2 \times 10^{-7} \ll 1$ as expected.

3.1.3 Characteristics of microwave power transmission

Characteristics of the microwave or wireless power transmission are presented below.^{5,6}

1. Applications of MPT

The main application is an SPS. Some other applications are explained in Section 3.5 (Spin-off technologies). More applications are introduced in Appendix A.

2. Characteristics of the MPT signal

The bandwidth of the SPS is quite narrow since an essentially monochromatic wave is used without modulation. An interference assessment at 2.45 GHz was published in IEEE Microwave Magazine.⁷ If power flux densities of harmonics of the WPT frequencies are regulated by the ITU power flux density (PFD) limits, some modulation might be necessary.

3. Category of spectrum: ISM, or other?

The industrial, scientific and medical (ISM) bands at 2.45 and 5.8 GHz, which are common in frequency allocation throughout the world, have been used for WPT applications for demonstration and experimental purposes. The 2.45 GHz ISM band (2,400-2,500 MHz) and the 5.8 GHz ISM band (5,725-5,875 MHz) are allocated to various services. Recently, the 2.45 GHz ISM band has been widely used for Radio LAN (IEEE 802.11b and g) applications. The 5.8 GHz ISM band is also heavily used for various applications. The 5,725-5,850 MHz band is allocated to Radiolocation service and is expected to be used for Dedicated Short-Range Communications (DSRC) applications described in Recommendation ITU-R M.1543-1. The 5,850-5,925 MHz band is allocated to

Fixed/Mobile services and is used for terrestrial ENG (Electronic News Gathering) in some countries including Japan. The upper half, 2.45-2.5 GHz cannot be used for SPS as the second harmonic is allocated to radio astronomy (4.9-5.0 GHz). It should be noted that these commercial applications are designed at low cost and are quite vulnerable to interference.

4. Most suitable frequency bands

Suitable frequencies for Space-to-Ground WPT such as an SPS and related satellites are 1-10 GHz (the radio window) in order to avoid atmospheric absorption and ionospheric scintillation as high transmission efficiency is essential for SPS. Since the ISM bands are widely used in various fields, however, frequencies other than these bands should also be taken into consideration. As compatibility with wireless communications is one of the most important issues, interference simulations will be conducted in the future. Suitable frequencies are different in applications other than Space-to-Ground WPT.⁸

5. Effects on radio propagation

The SPS must radiate at intensities lower than the safe level (1mW/cm²) outside the reception field. No effect on the propagation has been found except for a case under an intense electric field,⁹ although the intensities exceed the safe level. Near the satellite, however, the power density will be high and its effects on the ionosphere or the magnetosphere shall be examined experimentally.

3.2 Microwave devices

Microwave semiconductors and vacuum tubes are reviewed.

3.2.1 Microwave semiconductors

From manufacturing points of view, semiconductor technologies being advanced currently should benefit the SPS technology. Silicon based devices and III-V or other compounds have been investigated extensively by the electronic industry and solid state research groups all over the world. Recent progress in GaN and SiC technologies may provide significantly improved power output. Reliability in space needs to be investigated. Power added efficiency (PAE) and the thermal properties of the devices need to be improved if cooling is difficult in space. Also important is a phase-locked power combining scheme at the device, circuit and quasi-optical levels.

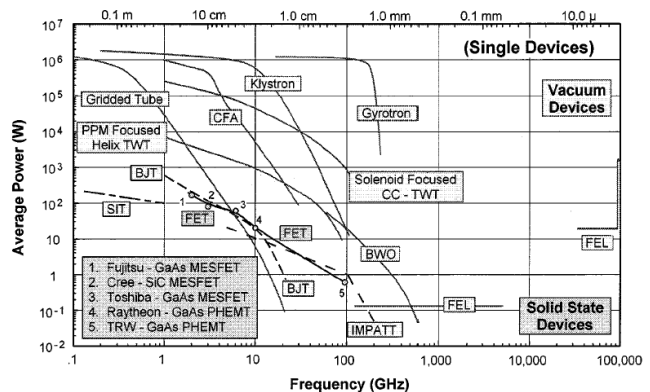

Fig. 3.2.1 Average RF output power versus frequency for various electronic devices¹⁰ and semiconductors.¹²

Semiconductor spatial-power-combining oscillator arrays are addressed for the SPS.¹¹ The oscillator arrays consist of optical-link distribution networks, phase-correction loops, and extended resonance oscillator arrays. The beam-scanning capabilities are investigated.

Trew¹² reviewed state-of-the-art microwave semiconductor technology. The current state of the art of microwave solid-state devices and microwave tubes is shown in Fig. 3.2.1. GaAs metal-semiconductor FETs (MESFETs), GaAs pseudomorphic high electron mobility transistors (PHEMTs), and SiC MESFET have the best of semiconductors. The output of a single solid-state device is less than 100W, but higher output power can be obtained through power-combining and phased-array technology. Recent improvements in the growth of wide bandgap semiconductor materials, such as SiC and the GaN-based alloys, provide the opportunity to design and fabricate microwave transistors that demonstrate performance previously available only from microwave tubes. Microwave power amplifiers fabricated from 4H-SiC MESFETs and AlGaIn/GaN HFETs have an RF power performance, particularly at an elevated temperature, superior to comparable components fabricated from GaAs MESFETs or Si transistors.

3.2.2 Microwave vacuum tubes

The average RF output power versus frequency for various electronic devices is shown in Fig. 3.2.1. Some of the SPS designs are based on a microwave power transmitter with microwave tubes such as klystrons and traveling wave tubes (TWTs). The electronic tubes are characterized by their high efficiency (>70%) and high power output (normally of the order from several hundreds of watts to kW). Since the output power is a few to 10 W per element in the typical cases, the high power from one electronic tube must be distributed to individual antennas via power dividers. A recent analysis shows that the vacuum tube devices are superior to semiconductor devices for microwave power transmission system in terms of the weight per unit power, DC-to-microwave conversion efficiency, and total cost. Magnetrons have many advantages compared with other microwave devices. The output power of magnetrons can be much smaller than that of klystrons adopted in the NASA SPS reference system. Magnetrons are inexpensive because they are mass-produced for microwave ovens. They were, however, not entirely suitable for application to the SPS because they lack frequency and phase stabilities essential for the microwave beam control.

A new concept of a microwave transmitter, called a phase controlled magnetron (PCM),¹³ satisfying both requirements of high efficiency and beam controllability, has been developed. A new phased-array system with the PCMs is also proposed for the SPS. The injection-locking technique and phase-locked loop (PLL) feedback by controlling an anode current are used for the PCM. The PCM can stabilize and control the frequency and phase of the microwave. A phased array with a phase and amplitude controlled magnetron (PACM) has recently been proposed.¹⁴ The PACM is developed with an injection locking technique and PLL feedback to an anode current for frequency and phase control and to an external coil current controlling the magnetic field for amplitude control.

3.2.3 Phase shifters and power dividers

Microwave technology development is essential to the MPT. Examples of microwave devices to be developed are listed below.

- 1) High-efficiency power transmitters with low harmonics
Very low harmonics and spurious emissions are required to avoid interference with communications.
- 2) Low-loss phase shifters
Drive currents to control PIN diodes used in phase shifters are not negligible since the order of power losses of the diodes is comparable to the power treated.
- 3) Low-loss power dividers
Losses are especially high in high-power stages.

3.2.4 Microwave devices, circuits, and systems

(1) Power generation devices and circuits

Many advanced solid state devices have recently been developed and improved. For instance, wide-bandgap devices such as GaN have significant power outputs particularly at relatively low microwave frequencies of 2.4 and 5.8 GHz. Linearity and efficiency are always desired not only for these devices but also for many other applications. From the viewpoint of manufacturing huge quantities required for SPS, III-V based devices have disadvantages over Si-based devices, simply because III-V compounds are not abundant or cheap. Associated circuit technologies such as high efficiency amplifiers need to be advanced while keeping their linearity. This is a challenge even for conventional communication and radar applications but is particularly relevant to SPS where the total power is huge and loss abatement in order to decrease the heat generation in space is a problem. Power combining schemes have also been investigated. To date, however, no convincing results practical to the MPT have been realized.

It is important to seek alternative solutions such as vacuum tube technology, while keeping the efficiency, linearity and reliability issues in mind.

(2) Beam Control

It is important that all power should be harvested in the MPT as opposed to enhancement of the antenna gain for the specific target in the case of conventional phased-array systems. Pointing of the beam is another important issue. In the past, retrodirective methods based on the phase conjugation and digital control as well as combination thereof has been investigated. These technologies should receive more attention particularly in connection with total SPS architecture and control aspects.

(3) Power recovery on the ground

Rectennas based on efficient diodes have been the primary vehicle for this subject. Although DC conversion efficiency exceeding 80% has been demonstrated in the laboratory environment, the large-scale feasibility has not been tested. In addition, there may still exist some room for improvement in both circuit technology and device technology. It should be investigated if there exist any other power recovery methods with potentially superior overall system efficiency.

Rectennas consist of antennas and rectifiers for transforming microwave to direct current (DC). The development of a highly efficient system is essential. The power densities in the receiving area are not constant. How to combine rectenna elements with

different output powers is also important for the total efficiency. Harmonic emissions generated by the nonlinearity of the diode rectifiers should be minimized.

(4) Emerging Technologies

There may be possibilities to use new material and device development such as carbon nanotubes and other exotic materials including artificial or metamaterials for new devices and components. Circuit architecture and technology require a new look from the MPT point of view rather than traditional microwave communication and sensor applications. Issues include high power, large-scale deployment, manufacturability, efficiency, linearity, reliability and controllability.

5 Active Integrated Antenna (AIA)

There are unique developments for the SPS from the microwave point of view as distinguished from the ordinary use of the microwave technology such as telecommunications. These three points include 1) pureness in spectrum, 2) high-power and high-efficiency power generation and highly efficient detectors in small, light packages, and 3) precise beam control for a large phased-array antenna combining a huge number of subarrays.

To cope with the second requirement for the microwave technology, the large plate model with a layered sandwich configuration was proposed. The advantage of this configuration is the effective integration with DC power generation, microwave circuit operation and radiation, and their control. The Active Integrated Antenna (AIA) technique is also considered.

The AIA is defined as a single entity consisting of an integrated circuit and a planar antenna. The AIA has many features applicable to the SPS. The small, thin, light and multifunctional AIA can realize a power transmission part of the spaceterenna (space antenna) with a thin structure.

The AIA is roughly categorized into two types: the cavity type and the array type (Fig. 3.2.2). The cavity type AIA consists of a resonant cavity and a gain medium plate composed of a solid-state device and a radiator. In this case, the gain medium is made with a high-density active device alignment resulting in the high power generation by mode locking. In the array type AIA, periodic alignment of the active device and the radiator for producing the selected mode is adopted. As a result, the AIA is made more compact by removing the resonant cavity. By using these natures, many applications of the AIA have been proposed. For instance, a 2x2 AIA panel array was demonstrated in Fig. 3.2.3.¹⁵

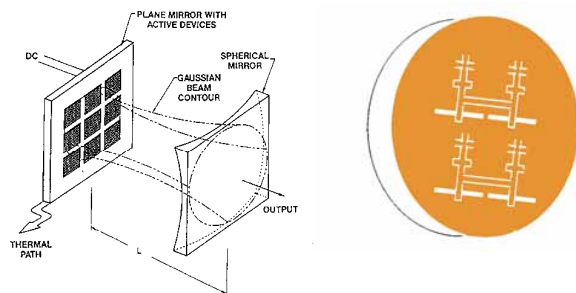

(a) Cavity type! ! ! ! ! (b) Array type

Fig. 3.2.2 Category of AIA.¹⁶

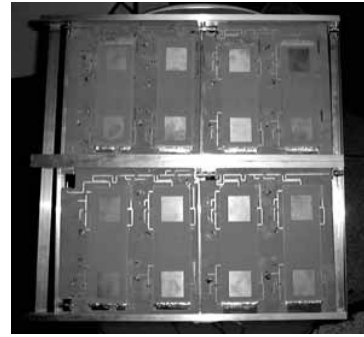

Fig. 3.2.3 The 2x2 AIA panel array.¹⁵

3.3 Beam Control

High transmission efficiency is essential for the SPS. In order to attain this efficiency, a huge antenna system is required. Phase synchronization among units becomes important since the system is too huge to distribute a reference signal to all the units. A retrodirective system is used in transmitting power in the direction of an arriving pilot signal. Precise beam control, low sidelobes, and low grating lobes are necessary in this system. Effects of amplitude and phase errors should also be taken into account.

3.3.1 Transmission efficiency

If all elements of an array are equally excited, this is simple and the gain factor and antenna efficiency become maximal, but the main beam covers only a part of the total energy. For higher transmission efficiency, a rectenna site must cover the first sidelobe including the first null. This needs more area and is inefficient since the extended area includes a weak region. Sidelobe levels decrease slowly as a function of a distance from the center, and sidelobes have higher energy and could interfere with nearby communications. When the distributions on the transmitter aperture are Gaussian (Gaussian taper), a high transmission efficiency is obtained. The fact that the output power is maximal at the center of the transmitting array, however, causes the following problems. The output power of the center amplifiers is the maximum and heat dissipation is quite difficult. Although different kinds of outputs for the Gaussian distribution are necessary in the array, their efficiencies should be high. The same effects as the tapering could be obtained under the equal excitation if phases of the elements are adjusted properly through optimization methods such as genetic algorithms and particle swarm optimization.¹⁷

Three kinds of antenna configurations for the SPS, array of small radiators, array of apertures, and a single aperture, are presented and their realization is compared.¹⁸

3.3.2 Phase synchronization among units

An SPS system is so huge that the array is composed of many units. 'Unit' is defined as the area where the surface of the array is assumed to be flat from the view point of antenna with an accuracy of less than 0.1 wavelength. The system is too large (a kilometer) to distribute a reference signal generated by a single reference oscillator. Although beam steering is possible in each unit, a beam radiated from a unit could cancel that of another one depending on the phases of their reference signals. Although the reference signal could be distributed by cables, optical fibers,

or radio, it would be difficult to use it as a phase reference for an oscillator because the cable length and phase shift inside each circuit must be taken into account. If independent oscillators are used, their requirements for stability and accuracy would be quite strict. Although their frequency can be synchronized, it would be difficult to adjust their phases. Some studies on the phase adjustment have been conducted.¹⁹

3.3.3 Retrodirectivity

A rectenna site sends a pilot signal to the SPS in order to indicate its position. The SPS system sends a power beam back to the rectenna site. This is called retrodirectivity, in which a signal is reflect back in the direction of the incoming signal as described in section 2.3.5. A signal from each antenna element (radio frequency; RF) is mixed with a local oscillator (LO), and the intermediate frequency (IF) signal is transmitted back through the antenna element in the direction of the sender. The lower sideband of the output of the mixer is a phase conjugation of the received signal as shown below.²⁰

$$\begin{aligned} V_{IF} &= V_{RF} \cos(\omega_{RF}t + \theta_n) \times V_{LO} \cos(\omega_{LO}t) \\ &= \frac{1}{2} V_{RF} V_{LO} \{ \cos((\omega_{LO} - \omega_{RF})t - \theta_n) + \cos((\omega_{LO} + \omega_{RF})t + \theta_n) \} \end{aligned} \quad (3.3.1)$$

The sign of the phase part θ_n of the lower sideband, $\omega_{LO} - \omega_{RF}$, is opposite to that of the input, ω_{RF} . For safety, any coherent beam should not be transmitted if no pilot signal exists for safety. The number of hardware systems is the same as that of antenna elements, totaling more than several hundred million in the SPS. It would be unrealistic to apply this system to all elements. Let's call this the hardware retrodirective system. The number of receiving elements is the same as that of transmitting elements and is huge in the SPS. Calibration of each element would be quite difficult.

A transmitter and frequency doubler are demonstrated with high-efficiency AlGaIn/GaN based on a HEMT active integrated antenna (AIA).²¹ Their application to retrodirective arrays based on the above principle and their use for beam-control applications to the SPS are also presented. The transmitting frequency is equal to the pilot frequency, ω_{RF} if $\omega_{LO} = 2\omega_{RF}$.

A retrodirective control transmitter was developed and demonstrated.²² A subarray is composed of 63 5.8 GHz-microstrip patch transmitter antennas and a 2.9 GHz antenna. Two subarrays are used for the demonstration. The phase conjugation was attained through a digital signal processor at down-converted 10 MHz signals.

3.3.4 Software retrodirective system

The retrodirectivity can be attained by measuring the direction of arrival (DOA) with fewer elements and setting the direction of the beam of the transmitting array to the DOA. This method is less expensive than hardware methods and various beam-forming methods can be applied. We call this the software retrodirective system. This system forms beams using optimization methods like genetic algorithms and particle swarm¹⁷ in order to obtain lower sidelobes, high transmission efficiency, and multiple beam formation. This method is expected to be feasible in the SPS as the required response time for the change of arrival directions can be slower than

communication applications.

A new beam control system for SPS is proposed and demonstrated.²³ This system is a kind of software retrodirective system and uses a spread-spectrum pilot signal for the DOA estimation. The same frequency is used for power transmission and a carrier of the pilot signal and the DOA is measured under the transmission. Band-pass filters and software synchronization are used.

3.3.5 Effects of antenna array amplitude and phase errors

Accurate beam control is necessary for maximizing energy transfer to the Earth and limiting radiation in the undesired directions so that existing telecommunication systems are not adversely affected. The center of the microwave beam should stay confined to within 0.0005 degrees of the center of the rectenna. A retrodirective system will be used for this severe requirement. The beam control accuracy of the SPS-MPT system will be achieved by a huge number of the power-transmitting antenna elements. The beam control accuracy is proportional to phase errors of each subarray and $N^{3/2}$, where N is the number of subarrays.²⁴ N depends on the total diameter of the transmitting antenna and spacing of subarrays. The phase errors must include errors in target detection, structure distortion errors, and errors of phase shifters. In order for an SPS-MPT system to realize the 0.0005 degree beam control, the total phase errors in the system must be suppressed to a few degrees. These technologies are under research at present.²⁵ It is noted that the beam collection efficiency is as important as the beam control accuracy. The beam collection efficiency depends on the sidelobes and the grating lobes. Amplitude and phase errors of an antenna array do not cause significant errors on the direction of the main beam if these errors are not too large, but they can increase in the sidelobe level and decrease the transmission efficiency. They are not desirable for the SPS.

3.3.6 Current antenna technology and future forecast.

The antenna specifications for the SPS are still quite demanding. The best solution would be a hybrid design, combining the array technology and deployable reflector antenna technology. In this approach, we may also use a sparse array concept by filling the largest aperture with smallest number of elements. An antenna system with a reconfigurable beam-steering reflector is proposed.²⁶

Optimization methods such as genetic algorithms and particle swarm¹⁷ can be used in the optimal array configuration. Currently, mesh reflector antennas operating at the desired frequencies with up to 35-meter diameter are feasible. Additionally, due to the narrow band operation of the design, one may also consider membrane deployed Fresnel reflector antennas with much large diameters. These reflector/Fresnel antennas can be used as the elements of the large sparse array. Many issues need to be addressed including array topology, VLBI type operation among the elements, stability and self correcting, and power handling.

3.4 Rectennas

A rectenna is composed of a rectifier (diode) and an antenna. A high efficiency in the power conversion is essential. A typical

experimental satellite will transit 100-400 kW of 5.8 GHz microwave from 10-20m square phased array antenna in a low-Earth orbit to the ground, and a rectenna will receive less than 1mW of microwave power. High efficiency rectennas have been developed to cope with such low power are developed. Suppression of harmonics caused by the nonlinearity of diodes in a rectenna should also be studied as soon as possible. Low-power rectennas can be applied for ubiquitous power sources (see Sec. 3.6) and the RF-ID (radio frequency identification).²⁷

In a large rectenna array used for the SPS, the power density of the microwave beam is not constant over the entire array. The output of a large rectenna array composed of some rectenna panels depends on their connections because outputs of the panels are not the same. It is thus important to optimize the total output.²⁸ The power density in the rectenna site used for the SPS system has to be kept low for environmental health and safety. It is necessary to develop a high efficiency rectenna for low power.

It is important to use a diode with a low turn-on voltage for high efficiency rectennas. To rectify multiple octaves, a different approach from standard matching techniques was used. In a rectenna application, the antenna itself can be used as the matching mechanism instead of using a transmission-line matching circuit.²⁹

The sum of the outputs of two or three rectenna panels depends on whether they are connected in parallel or in series or in a hybrid configuration under the same microwave circumstances. Conclusions²⁸ based on the experiments are: (1) The sum of the dc outputs from two rectenna panels connected in parallel is larger than that from those connected in series. (2) The sum of the dc outputs of two rectenna panels is generally smaller than the sum of the dc outputs of the individual panels unless their outputs are equal. (3) A higher output of dc power from a rectenna array can be achieved when the array elements are carefully balanced. Based on experiments, an optimum method is proposed for connection of individual rectenna elements to form a high-efficiency rectenna array. Obtained is a similar conclusion³⁰ that it is effective to divide the entire aperture by smaller apertures or smaller panels inverse-proportionally to the power density

Characteristics of almost all past rectennas are for rectifying over 100mW, and the RF-DC conversion efficiency is less than 20% at 1mW microwave input. Kyoto University recently developed a new mW-class rectenna. All circuit parameters were surveyed for a higher efficiency at 1mW microwave input, and the efficiency of a new rectenna at 1mW is approximately 50%. The new rectenna is composed of a printed-circuit dipole, an LPF and a rectifying circuit on a coplanar line whose impedance is 200Ω.

3.5 Measurement and Calibration

Measurement and calibration are important issues for the SPS and MPT. Some problems and test programs for the SPS system are described below.

3.5.1 Huge antenna array measurements on the ground and in space

Microwave measurements are necessary for evaluation of power, interference, spurious emissions, etc. The SPS uses a

huge antenna array on the order of kilometers. Its radiation pattern and output power must be evaluated before launch. The system requires retrodirectivity. Correct measurement of the arrival direction of the pilot signal is essential as well as precise beam steering with an accuracy of less than 100 m for the SPS in GEO at a distance of 36,000 km.

3.5.2 Rectenna measurements

Transmitters and rectennas radiate harmonics because of the nonlinearity of rectifiers used in them. A new method of measuring harmonics has been proposed.³¹

3.5.3 Self calibration of antenna gain and phase errors

Errors of antenna elements result in errors in the direction of arrival (DOA) estimation of a pilot signal and in the beam formation in the transmission. It would be important to make a self-calibration system for a large number of elements in the array. A very long baseline interferometry (VLBI) system for radio astronomy uses known stars as references for its calibration.

3.5.4 SPS Antenna Test Program

3.5.4.1 General Considerations.

Space is a harsh environment with large temperature gradients, high solar wind, and strong ionizing radiation. It is possible to approximate such physical conditions only in restricted laboratory environments. The testing of large antennas presents not only the usual difficulty of making accurate RF measurements on a substantial aperture, but also the unusual problems of devising tests that accurately predict the performance impact of the harsh mechanical and thermal conditions of the operating environment of the antenna.

The large assembly of panel arrays that constitutes the SPS antenna must be tested at each construction level for both electromagnetic and environmental performance. The following are building blocks of the antenna. 1) The basic radiating element, 2) A subpanel of size large enough to test the radiation pattern performance of the basic element in the array environment. This subpanel may be formed by assembling a few rows and columns of basic radiators. 3) An antenna panel, that is the array of radiating elements that is repeated to form the SPS antenna, 4) The whole SPS antenna.

The test program consists of radiation measurements and data collection to evaluate by computer extrapolation the performance of the SPS antenna in the extraterrestrial environment.

3.5.4.2 SPS Antenna Element Test Program.

The basic antenna element can be tested both for radiation and environmental performance in conditions close to those of space.

If temperature gradients are expected between the front (radiating side) and the back (feed side) of the element, these environmental temperature conditions should be reproduced as closely as possible during the radiation test program.

The radiation patterns, the gain and the feed matching conditions over the operational frequency band can be evaluated by the usual means of an antenna test site and a network or antenna analyzer. The antenna should be placed over a ground plane of dimension close to the subarray discussed in the next

section.

Of interest is the evolution of the antenna element performance with aging in space. The ionizing radiation, the temperature gradients and the particle bombardment change the metal and dielectric properties of the construction materials. Some materials may have been used for space application and historical data may exist on their aging. Whether novel materials are employed or not, it is suggested that an accelerated aging test program be performed on the radiating element and the antenna performance be evaluated at various stages of the aging test to establish the limits of acceptable performance.

With the highly automated instrumentation available from a variety of suppliers it is possible to prescribe a very detailed test set of gain and matching conditions for the antenna element. Over the bandwidth of the radiator 100 match and boresight absolute gain measurements should be collected for initial performance evaluation. Hemispherical radiation maps (contour plots) for polarization and cross polarization do not need to be recorded with such repetition. Only five recordings over the operating band should suffice.

A much more detailed test program can be established as the element design nears completion, depending on the materials and the geometry of the radiator.

3.5.4.3 SPS Antenna Subarray Test Program.

This program evaluates, under extraterrestrial environmental conditions, the performance of the radiating elements within the array and investigates the effects of aging on their gain, pattern and matching conditions. This step is necessary because it may not be possible to realistically test the performance of an entire panel in simulated space ambient conditions. If such testing is possible, then the subarray test program could be skipped. However, it is good engineering practice to simulate the effects of mutual coupling between the array elements without building an entire array antenna.

The mutual coupling between array elements can substantially change the performance of the single radiator in terms of matching and pattern performance. With aging of materials, the coupling conditions can give rise to substantial reflections at the element aperture and surface waves over a dielectric layer covering the antenna. Most effects can be predicted by computer simulation, but a test program is an insurance of later performance.

Without the specific element physical design, it is possible to give only some general rules for the construction of a subarray. The strongest intra-element coupling happens in the plane of the E-polarization, the weakest in the H-plane. It is possible to reproduce array conditions for an element by constructing a subpanel of 11 rows and five columns of radiators. Only the element at the center of the subpanel needs to be excited, all the others can be match-terminated.

As in the case of the single element program, the tests evaluate the effects of the space environment on the radiation and matching conditions of the subpanel gather data for confirming the computer simulation of the SPS array performance.

Space ambient temperature gradients should be recreated during the tests to investigate their effects on possible warping of the radiating elements and their mechanical support structure. The adverse effects of aging of the array materials with

temperature changes, ionizing and particulate radiation can be detected during this test program. Subtle changes in the array element pattern point to degradation of side lobe performance. Changes in gain, polarization and matching conditions (return loss) should be carefully analyzed for the possible degradation of the SPS antenna.

With computerized data collection, absolute boresight gain and return loss measurement losses can be performed at 100 frequencies equally spaced over the SPS antenna band.

As in the case of the single isolated element, hemispherical radiation maps can be collected for the E-field polarization and the cross-polarization.

3.5.4.4 SPS Panel Test Program

The SPS antenna is formed by assembling a number of arrays. The physical size of these antennas is large and the costs of simulating the temperature gradients in space over the extent of the array may be prohibitive. From the subarray test program data, the maximum possible mechanical misalignment of the array elements can be computer simulated and may not need to be tested. The array tests consist of gain measurements, radiation patterns and radiation maps (contour plots of the sidelobes). The contour plots may not be difficult to measure if the panel is too large to be tested with an antenna positioner in an open range.

Given the size of the SPS antenna panels, the measurement of gain and radiation patterns are most conveniently performed in a compact range.³² Following the methods given in,³² it is possible to compensate for many of the measurement errors arising in a compact range. A spherical or a planar compact range can be used for this set of measurements

The evaluation of the far out sidelobes is always somewhat compromised in a compact range. A well designed open range is the best means to collect contour plots of an antenna's far sidelobes. The antenna must be mounted on a two- or three-axis positioner. It is advisable to reduce the size of a panel so it can be tested on an open range, for two reasons.

- 1) Far sidelobes can be mapped with accuracy.
- 2) It is necessary to test the effects of panel warping and spacing on the far out sidelobes.

Although computer simulations can predict with some precision the effects of geometrical changes on the sidelobes, it is always a good engineering practice to test the accuracy of the computations. A large antenna positioner (e.g. from Scientific Atlanta) can orient with great accuracy (few milliradians) a large and heavy structure up to 100 kg. It is suggested that a support structure be built for at least two panels of the SPS and the effects of panel separation and warping on gain and sidelobe performance be tested experimentally.

The data collected in this test phase make it possible to construct realistic computer models for the performance of the SPS antenna.

These considerations point out the advisability of building an ensemble of panels as large as feasible for testing in a compact and an open range.

3.5.4.5 SPS Antenna Test.

The antenna is expected to be so large that it cannot be tested in its entirety on the ground. Computer simulations can give a sufficiently close evaluation of expected antenna performance in terms of gain, beamwidth and near sidelobes.

The antenna can be tested with some accuracy once in orbit. A series of gain and pattern tests can be performed with receivers on airplanes or a group of RF receivers located in predetermined positions on the ground. These measurements are performed to substantiate the computer simulations performed in the previous phase of the tests.

These measurements should be performed with reduced RF power from the SPS until it has been tested that the beam is positioned on the collector-receiver and that no strong sidelobes radiate in unwanted areas.

3.6 Spin-off technologies

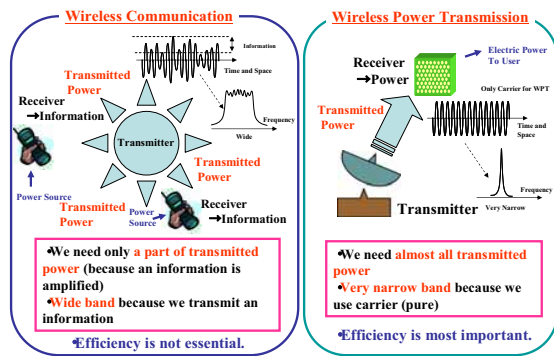

Fig. 3.6.1 Difference between wireless communication and wireless power transmission. ©RISH, Kyoto University

The wireless power transmission (WPT) technologies including MPT are not only applied to the SPS, but also have applications on the ground. The WPT and wireless communication technology are fundamentally the same technology. Maxwell's equations govern both. The difference is the viewpoint of waves (Fig. 3.6.1). For wireless communication, a radio wave is used only as a carrier of information. The WPT system uses the carrier of a radio wave. Therefore, almost all transmitted power must be received and only a very narrow band is necessary. Efficiency is very important for the WPT system. The power densities are different. The WPT uses many orders of magnitude higher power density than communications. The energy carrying wave is in principle a monochromatic wave without modulation.

The advantages of the WPT over conventional power transmission using stationary conducting lines are as follows.

- ! As WPT does not need any power lines connecting a power generator and power consumers, it has more freedom of choice of both transmitter and receiver locations. Even mobile transmitters and receivers can be chosen for the WPT system.
- ! One transmitter site can distribute power toward multiple customers simultaneously like broadcasting.
- ! A receiver called a rectenna is lighter than a commonly used batteries or photovoltaic cells. Furthermore, power is available at rectenna sites as long as the WPT is operating. This removes the worry of a power shortage due to battery exhaustion.

The power loss of WPT is much less than that of line transmission although this depends on antenna aperture sizes. The power loss in propagation is less than 1% even for a long distance transmission of several tens of thousands kilometers

like used for the SPS.

One application is the MPT for moving targets, e.g., a fuel-free airplane, a fuel-free electric vehicle (EV), and moving robot in a limited area. In the late 1980's, Canada proposed a program to develop a long-endurance, high-altitude platform called SHARP (Stationary High Altitude Relay Platform).³³ The idea is to float an unmanned light-weight airplane for a long period, circling at an altitude of about 21 km for the purpose of relaying radio communications signals over a wide area. To maintain the platform airborne for weeks or months, fuel-less airplanes powered by microwave energy transmitted from the ground were proposed and investigated by experiments in Canada and in Japan. The Japanese experiment was called MILAX (Microwave Lifted Airplane eXperiment).³⁴ In Japan, MPT to an electric vehicle (EV) was also proposed and the MPT experiment was carried out with small scale functional model of the EV.

Another application of the MPT is ground-to-ground (G-to-G) power transmission without wires toward a distant place where wired power distribution networks are either unavailable or with very poor distribution. Two experiments were carried out, one in the USA in 1975 and one in Japan in 1995-96. In the Japanese experiment, fundamental data on microwave power transmission were collected under various weather conditions and experiments on the connection of the rectennas were carried out. The merits of the G-to-G MPT are quick installation and easy disassembly because there are no lines between the transmitter and the receivers. The MPT can thus be used as an emergency power supply.

The most recently proposed MPT application is "Ubiquitous Power Source (UPS)" or "Wireless Power Source." In a ubiquitous power source, where power is fed via microwave, one can extract electric power from weak microwaves anywhere and at any time. Laboratory experiments have already been carried out in a shielded room.³⁵ In the UPS concept, the use of the microwave is very similar to that in the communication system. The emitted microwave expands and weak microwave power is received in many receivers. A recent system similar to UPS is RF-ID (radio frequency identification). The RF-ID is based on a chip. This chip carries information that can be retrieved through radio waves. The power used in the chip is also provided by the radio waves. The most common application of the RF-ID is a verification system. This is also called an "IC tag," and is receiving attention all over the world, in the form of standardization and research. The rectenna technology can be applied to the rectifier of the RF-ID.

Presently, most RF-ID research assumes the 915 MHz band. RF-ID is still in the development phase. If energy exchange through microwaves becomes necessary for RF-ID, rectennas would be necessary. However, to our knowledge, only communication needs are being studied. Hitachi has come up with a micro-chip operating near 2.45GHz.³⁶ It is a super-miniature RF-ID chip, called μ chip. It has dimensions of 0.4mm×0.4mm×0.06mm, and is being pursued so that it can be inserted into a sheet of paper. The rectenna part of a μ chip is shown in Figs. 3.6.2 and 3.6.3.

Table 3.6.1 RF-ID and frequencies³⁷

Frequency	120-150kHz	13.56MHz	915MHz	2.45GHz
Method	Electromagnetic induction	Electromagnetic induction	Microwave	Microwave
Distance	∩ 50cm	∩ 1m	∩ 5m	∩ 1m
Cost	fair	good	Very good	excellent
Applications	Immobilizer (car theft prevention) Livestock control	IC card Baggage control		μ chip

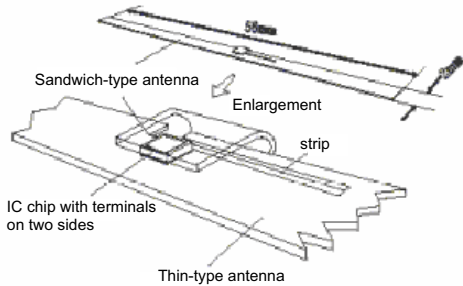

Fig. 3.6.2 μ-chip antenna³⁸

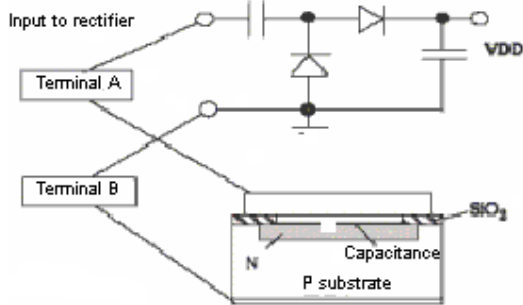

Fig. 3.6.3 μ-chip rectifier³⁸

¹ W. C. Brown, Beamed microwave power transmission and its application to space, *IEEE Trans. Microwave Theory Tech.*, vol. 40, no. 6, 1239-1250, 1992.

² Similar results are obtained in Uno, T. and S. Adachi, A design of microwave wireless power transmission by the aperture illumination of maximum transmission efficiency (in Japanese), *IEICE Trans.*, vol. J66-B, no. 8, 1013-1018, 1983.

³ G. Goubau and F. Schwing, On the guided propagation of electromagnetic wave beams, *IRE Trans. Antennas and Propagation*, AP-9, pp. 248-256, 1961.

⁴ Kraus, J.D., *Antennas* (2nd ed.), McGraw Hill, 1988.

⁵ This is based on a Response to the Question ITU-R 210/1 on wireless power transmission in ITU by the following contribution; JAXA, Present status of wireless power transmission toward space experiments, Document No. 1A/53-E, ITU Radiocommunication study groups, October 1, 2004.

⁶ Each item corresponds to that of the Question ITU-R210/1.

⁷ T. Hatsuda, K. Ueno., and M. Inoue, Solar power satellite interference assessment, *IEEE Microwave Magazine*, vol. 3, no. 4, 65-70, December, 2002.

⁸ Applications and Characteristics of Wireless Power Transmission, Document No. 1A/18-E, Task Group ITU-R WP1A, Reference Question 210/1, ITU Radiocommunication Study Group, October 9, 2000.

⁹ Matsumoto, H., Microwave power transmission from space and related nonlinear plasma effects, *Radio Science Bulletin*, no.273, pp.11-35, June 1995.

¹⁰ V. L. Granatstein, P. K. Parker, and C. M. Armstrong, "Scanning the Technology: Vacuum Electronics at the Dawn of the Twenty-First

Century," *Proc. IEEE*, vol. 87, pp. 702-716, May 1999

¹¹ J. Choi and A. Mortazawi, Free-space power-combining oscillator array for solar power transmission, *The Radio Science Bulletin*, no. 311, 47-53, 2004.

¹² R. J. Trew, SiC and GaN Transistors—Is There One Winner for Microwave Power Applications?, *Proc. IEEE*, vol. 90, no. 6, 1032-1047, June 2002.

¹³ Naoki Shinohara, Hiroshi Matsumoto, and Kozo Hashimoto, Solar power station/satellite (SPS) with phase controlled magnetrons, *IEICE Trans. Electron.*, E86-C, 1550-1555, 2003.

¹⁴ Naoki Shinohara and Hiroshi Matsumoto, Design of Space Solar Power System (SSPS) with Phase and Amplitude Controlled Magnetron, *Proc. of 2004 Asia-Pacific Radio Science Conference*, pp.624-626, 2004.

¹⁵ Shigeo Kawasaki, A unit plate of a thin, multilayered active integrated antenna for a space solar power system, *The Radio Science Bulletin*, No.310, pp.15-22, 2004.

¹⁶ S. Kawasaki, A Patch-Plate Array Type of Active Integrated Array Antenna for SPS2000, *ISAS Bulletin*, 43, pp. 47-55, 2001.

¹⁷ Y. Rahmat-Samii, et al, Particle Swarm Optimization (PSO): A novel paradigm for antenna designs, *The Radio Science Bulletin*, no. 305, 14-22, 2003.

¹⁸ T. Takano, A. Sugawara, and S. Sasaki, System considerations of onboard antennas for SPS, *The Radio Science Bulletin*, no. 311, 16-20, 2004.

¹⁹ e.g., R. Chernoff, R., "Large Active Retrodirective Arrays for Space Applications," *IEEE Trans. on Antennas & Propagation*, Vol. AP-27, No. 4, pp. 489-496, July 1979.

²⁰ R. Y. Miyamoto and T. Itoh, Retrodirective arrays for wireless communications, *IEEE Microwave Magazine*, vol. 3, no. 1, 71-79, March 2002.

²¹ K.M.K.H. Leong, et al., Active antenna approach for power transmission. *The Radio Science Bulletin*, no. 311, 21-30, 04.

²² F. E. Little, et al., Development of a retrodirective control transmitter for wireless power transmission, *ibid*, 38-46, 2004.

²³ K. Hashimoto, et al, Space solar power system beam control with spread-spectrum pilot signals, *ibid*, 31-37, 2004.

²⁴ R. J. Mailloux, *Phased array antenna handbook*, Artech House, 1994.

²⁵ N. Shinohara, Y. Hisada, M. Mort, and JAXA SSPS WG4 Team, Request and Roadmap for Microwave Power Transmission System of Space Solar Power System (SSPS), *Proc. of IAF2005, Japan*, 2005.

²⁶ Varadan, V.K., J. Xie, K.J. Vinoy, and H. Yoon, Nano- and Micro-Devices for Performance Improvement of Space Solar Power System, *The Radio Science Bulletin*, no. 310, 36-46, 2004.

²⁷ See, 3.6 Spin-off technologies.

²⁸ Shinohara, N. and H. Matsumoto, Dependence of dc Output of a Rectenna Array on the Method of Interconnection of Its Array Elements, *Electrical Engineering in Japan*, 125, 9-17, 1998.

²⁹ J. A. Hagerty et al., Recycling Ambient Microwave Energy with Broadband Rectenna Arrays, *IEEE Trans. on Microwave Theory and Techniques*, Vol. 52, Issue 3, pp. 1014 – 1024, March 2004.

³⁰ Murao, Y., and T. Takano, An Investigation on the Design of a Transmission Antennas and a Rectenna with Arrayed Apertures for Microwave Power Transmission, *Electronics and Communications in Japan*, vol.83, no.2, 1-9, 2000.

-
- ³¹ Y. Fujino and M. Fujita, An experimental study of re-radiation of higher harmonic waves from a rectenna for microwave power reception, IEEJ Trans. Vol. 117-A, No. 5, 490-495, 1997 (In Japanese).
- ³² D. A. Leatherwood and E.B Joy, Plane Wave, Pattern Subtraction, Range Compensation, IEEE Trans. on Antenna and Propagation, Vol. 49, No. 12, December 2001, pp 1843-1851.
- ³³ J. J. Schlesak, A. Alden and T. Ohno, A microwave powered high altitude platform, IEEE MTT-S Int. Symp. Digest, 283-286, 1988.
- ³⁴ H. Matsumoto, et al., MILAX Airplane Experiment and Model Airplane, 12th ISAS Space Energy Symposium, Tokyo, Japan, March 1993
- ³⁵ N. Shinohara, T. Mitani, and H. Matsumoto, Study on Ubiquitous Power Source with Microwave Power Transmission, C07, Proc. of URSI GA, India, 2005.
- ³⁶ M. Usami and M. Ohki, The μ -chip: an ultra-small 2,45 GHz RFID chip for ubiquitous recognition applications, IETCE Trans, Electronics, vol. E86-C, no. 4, 521-528, 2003.
- ³⁷ SSK seminar, RFID business (in Japanese), January 23, 2004.
- ³ M. Usami, An Ultra Small RFID Chip: μ -chip (in Japanese), Microwave Workshop MWE2003, WS09-01, Yokohama, Japan, Nov. 2003.

Chapter 4 Influence and Effects of SPS

This chapter describes the SPS interaction with space and the atmosphere, compatibility with communications and radio astronomy, and influence of the SPS and MPT on human health and bio-effects; it also summarizes the pros and cons of the SPS. To assure environmental safety and health, the proposed limit of the maximum power at the center of the microwave transmission beam should be controlled by tightly tuned phased-array techniques and by automatic beam defocusing.

4.1 Interaction with space and the atmosphere

4.1.1 Atmospheric effects

Very few groups have worked on possible effects of microwaves on the atmosphere. Studies presently available refer to potential effects via heating of the ionospheric electrons or via ionization of the air. Observations of transient luminous events (sprites, blue jets, elves, ...) in the upper atmosphere set basic questions on the electrical processes that develop in the Earth environment. It is clear that new studies are needed on all phenomena that may influence the atmospheric electrical conductivity and thus the global electric circuit.

Heating of the ionospheric electron population may affect the ionospheric plasma and the atmosphere in different ways (see section 4.1.2). The effects are probably more important between 100 and 250 km where the main chemical process controlling the ionospheric plasma concentration is the electronic recombination of O_2^+ and NO^+ . They obviously depend on the level of enhancement in the electron temperature.

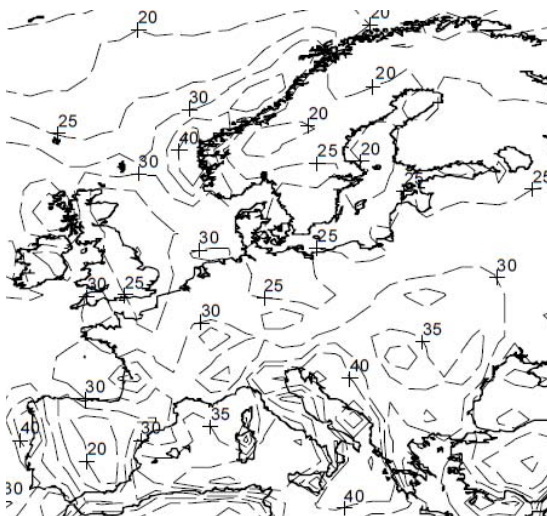

Fig. 4.1.1 Rain rate (mm/h) exceeded for 0.01% of the average year (Rec. ITU-R P.837-4).¹

The rain attenuation can be calculated based on

ITU-R PN618.² In case of Tokyo, the specific attenuation $\gamma_R = 0.2$ dB at 5.8 GHz since its rain rate is 50 mm/h for 0.01% of the time (about 52.5 minutes per year). Rain rates for a part of Europe are shown in Fig. 4.1.1. Since the effective path length $L_e = 4.5$ km, the value of attenuation $A = 0.9$ dB (81%). However, $\gamma_R = 0.1$ dB and $A = 0.45$ dB (90%) at 5 GHz. These values are smaller in Europe due to less rain as shown in the figure.

The microwave SPS beam is scattered by rain or hail.³ For a rain rate, $R = 50$ (mm/hour), frequency of 2.45 GHz, and the elevation angle of 47 degrees, the attenuation is about 0.015 dB/km. Furthermore, the maximum interference intensity P (W) received by an antenna for terrestrial radio relay links near the rectenna site for a power density of 23 mW/cm² is

$$P = 6.7 \times 10^{-11} R^{1.4} h,$$

where h (m) is the scatterer length. If $R = 50 \sim 150$ mm/hour and $h = 3 \sim 10$ km, then $P = 0.1 \sim 1$ mW. This level, however, would not cause nonlinear problems and interference can be removed by filters.

Batanov et al.⁴ studied the effects of powerful microwaves on the atmosphere have been studied both theoretically and experimentally. Of particular interest are the experimental studies devoted to cleaning the troposphere of ozone. The idea involves artificially ionizing the air using high power electromagnetic waves. The necessary threshold field strength and intensity are 680 kV/m and 6×10^4 W/cm² at 15 km, corresponding to a 6 GHz continuous wave. Since microwave pulses are used for the excitation of discharges, this breakdown electric field level can be several times higher. Although both levels are much higher than the values that will be achieved from the SPS, one sees that microwave radiation may have positive effects on the Earth environment. We also need to study and monitor potential negative consequences.

4.1.2 Ionospheric effects

Although much more published works are available, there are no conclusive observations or propagation models to provide a definitive view about the effects of microwave radiations on the ionosphere.

(1) Ohmic heating

The first obvious effect of high power microwaves on the ionosphere is resistive or Ohmic heating. The absorption of the radio waves can be calculated from the electron density and electron-neutral collision frequency profile. The effect is largest in the lower ionosphere (D and E regions) where the collision frequency is highest. Although the effect is expected to be small with

increasing frequency, it could still be significant. Several authors⁵ have calculated the heating effect of 3 GHz waves. They estimate that, for a power density of about 16 mW/cm², the electron temperature could increase from about 200 K in the E region to about 1000 K. A temperature increase would result in a decrease of electron density because of a decrease in the temperature-dependent recombination rate of O₂⁺ and NO₂⁺. In the D region an increase in the attachment rate to O₂⁺ also reduces electron density. To our knowledge no measurements of electron heating from high power microwaves in the ionosphere exist. The reason is probably two-fold: the difficulty of measuring electron temperatures on short time scales in the D region, and the lack of microwave heating experiments. Even if VHF and UHF radars of sufficient power-aperture produce heating effects, it is difficult to use them as both heating and measuring devices. It should also be noted that the heating effects may not be well represented by Maxwellian electron distribution function analysis⁶ that is often assumed in analysis of incoherent scatter radar data, so that standard analysis techniques may not be applicable.

Microwave injections from a rocket have been tried⁷ (and presented in a poster review⁸), but Ohmic heating effects could not be observed. The lack of measured microwave heating in the ionosphere should not cast doubt on the reality of Ohmic heating caused by powerful microwaves, but only points out the shortcomings of the attempts made so far to measure it. On this rocket flight, the expected heating effect was less than 100K, which was below the detection limit of the Langmuir probe. However, the illuminated plasma volume was very small.⁷

Because the ionospheric heating efficiency varies as the inverse square of the radio frequency, heating effects equivalent to those from high-power microwaves can be achieved at much lower powers by heating at a lower frequency. This is done using ionospheric modification or heating facilities that are simply high-power (~1MW) short-wave (2 to 10 MHz) transmitters radiating upwards using high gain (16 to 30 dB) antenna arrays. D-region Ohmic heating effects are clearly observable indirectly through the conductivity and current modulation experiments⁹ and the sometimes dramatic heating effects on polar mesospheric summer radar echoes.^{10, 11} Direct measurements of the temperature enhancement using incoherent scatter radar are, however, difficult and rare.¹²

(2) Self-focusing effects

Thermal self-focusing takes place as a result of a positive feedback loop. Small natural density

fluctuations give rise to a spatial variation in the refractive index, resulting in slight focusing and defocusing of the microwave. This slight differential heating of the ionospheric plasma results in a temperature gradient driving the plasma from the focused region and thereby amplifying the initial perturbation. Such effects are well known and have been studied from HF-heating experiments, but it is unclear how important this is for an underdense plasma where the microwave frequency is much greater than the plasma frequency.

(3) Three-wave interactions

The heating effects discussed above are the result of non-resonant interactions with the plasma. Another effect of high power microwaves is the production of plasma waves through resonant interactions, in particular through parametric instabilities. There have been several theoretical predictions that microwaves at high power may produce instabilities in the ionosphere. Matsumoto¹³ and Matsumoto et al.⁷ demonstrated that the microwaves may decay into forward-traveling electron plasma waves (Raman scattering) or ion acoustic waves (Brillouin scattering) and a backward-traveling secondary microwave. The electron plasma waves could be Langmuir waves when the excitation is parallel to the geomagnetic field, or electron cyclotron waves for excitation perpendicular to the field. Dysthe et al.¹⁴ and Cerisier et al.¹⁵ examined the case of two powerful microwaves having a frequency difference equal to the local ionospheric plasma frequency, typically 2 to 10 MHz. The ponderomotive force, which is proportional to the product of the two electric fields, can be strong enough to excite a parametric instability that results in Langmuir waves being produced. One result of a ground-based radar experiment near 1 GHz¹⁶ shows that such effects may indeed take place in the ionosphere. The three-wave interactions are expected to be most effective in the F region, above about 170 km.

Apart from the radar experiment of Lavergnat et al.,¹⁶ there is, to our knowledge, only one other report of plasma waves being caused in the ionosphere by powerful microwave transmissions. This was from a 830W, 2.45 GHz transmitter on a mother-daughter Japanese rocket experiment (MINIX) where electrostatic electron-cyclotron waves at 3/2 the local electron gyrofrequency and electron plasma waves above the local plasma frequency were observed^{17,7} and presented in a poster review.⁸ It was found that the excited waves differed from the initial theoretical expectations¹⁸ in that the line spectrum expected from a simple three-wave coupling theory was in fact a broad spectrum, and the electron cyclotron

harmonics were stronger than the Langmuir waves. Both these features could be successfully modeled using a more realistic computer simulation¹⁹ where the nonlinear feedback processes were fully incorporated. From these simulation results, it was estimated that 0.01 percent of the microwave beam energy from the SPS would be converted to electrostatic waves.

In conclusion, there have not been enough experiments with powerful microwaves in the ionosphere to determine with confidence the importance of instabilities as a loss mechanism for the beam and as a source of plasma waves and heating of the ionosphere. In the neighborhood of the satellite the power density will be high and its effects on the ionosphere will be examined experimentally. Care must be taken in the choice of frequency separations if multiple frequencies are used to beam down the power. Effects on the atmosphere are not expected.

4.1.3 Effects of electric propulsion on the magnetosphere

In the process of SPS construction, large high-power electric propulsion systems are needed. The electric propulsion systems inject heavy ions accelerated by electrodes powered by the photovoltaic cells. For transformation of orbits around the equator, the heavy ions are injected perpendicular to the Earth's magnetic field. The injection can strongly disturb the electromagnetic environment surrounding the ion engine in the plasma sphere and the magnetosphere through interaction between the heavy-ion beam and the magnetospheric plasmas. The interaction between the heavy-ion beam and the magnetic field has been studied theoretically.^{20,21} Based on an MHD analysis, Chiu²⁰ predicted that Argon ion injection could excite Alfvén waves propagating along the magnetic field down to the ionosphere and being reflected back. He also predicted that injected Argon ions can accumulate in the magnetosphere, significantly changing the plasma environment. Curtis and Grebowsky²¹ showed that the bulk of the injected ion beam is not stopped in the magnetosphere. However, the relatively small fraction of the beam that is not stopped may give rise to a large distortion in the magnetospheric plasma population. They also evaluated possible loss mechanisms from the magnetosphere for this artificial ion component.

The interaction of the heavy ions and the surrounding magnetized plasma field has been studied by particle simulations using hybrid code, where motions of ions are solved as particles while electrons are treated as a neutralizing fluid. As an initial response to the injection, a shock structure can be formed in the ambient plasma

along with generation of magneto-hydro-magnetic waves and associated heating of the background plasmas.²²

It has to be noted that heating processes and parametric instabilities may also take place within the plasmasphere, in the neighborhood of the satellite. The plasma is less dense but there is a high level of wave activity. The artificial generation or loss of extremely low (ELF) and ultra low (ULF) frequency waves in that region may have consequences on the dynamics of the radiation belts

4.2 Compatibility with other radio services and applications

Undesired emissions, such as grating lobes, sidelobes, carrier noise, harmonics, spurious, and out-of-band emissions of any Space Solar Power System must be suppressed sufficiently to avoid interference with other radio services and applications, in accordance with the provisions of the ITU-R Radio Regulations (RR). This applies not only to any eventual full power operational systems, but also to all developmental, test and intermediate power prototype systems, both in space and on the ground. Hence this is a near term issue, even though it may take decades before full systems become operational.

Most SPS microwave systems are assumed to use frequency bands around 2.5 GHz or 5.8 GHz. These are allocated in the ITU-R Radio Regulations to a number of radio services and are also designated for Industry, Science and Medical (ISM) applications.

The ITU Radio Regulations define ISM applications as follows.

RR 1.15 Industrial, scientific and medical (ISM) applications (of radio frequency energy): Operation of equipment or appliances designed to generate and use locally radio frequency energy for industrial, scientific, medical, domestic or similar purposes, excluding applications in the field of telecommunications.

Note that as presently defined the ISM bands are for local use only.

The following Radio Regulations govern the use of the ISM applications.

RR 5.150 The following bands: 13,553-13,567 kHz, 26,957-27,283 kHz, 40.66-40.70 MHz, 902-928 MHz in Region 2, 2,400-2,500 MHz, 5,725-5,875 MHz, and 24-24.25 GHz are also designated for industrial, scientific and medical (ISM) applications. Radiocommunication services operating within these bands must accept harmful interference which may be caused by these applications. ISM equipment operating in these bands is subject to the provisions of No. 15.13.

RR 15.13 Administrations shall take all

practicable and necessary steps to ensure that radiation from equipment used for industrial, scientific and medical applications is minimal and that, outside the bands designated for use by this equipment, radiation from such equipment is at a level that does not cause harmful interference to a radiocommunication service and, in particular, to a radionavigation or any other safety service operating in accordance with the provisions of these Regulations.

The intended bandwidth of SPS emissions is quite narrow, as an essentially monochromatic wave without modulation will be used. As noted in Section 4.1.2, care must be taken in the choice of frequency separations if multiple frequencies are used to beam down the power.

4.2.1 Compatibility with other services such as Radio Astronomy

An interference assessment on mainly 2.45 GHz was published in IEEE Microwave Magazine.²³ The following is a partial list of mechanisms by which an SPS could cause interference.²⁴

- 1) The power transmission signal, its harmonics, and any sidebands that might be present in the fundamental frequency reference, which will appear coherently at all power amplifiers of the system.
- 2) Noise generated in the power output stages. This will not be coherent at individual power amplifiers and so will not be beamed like the power signal but spread much more widely in angle. The spectrum might only be a few tens of MHz wide if the transmitter elements are highly tuned (e.g. klystrons) and could be broader for solid-state devices.
- 3) Thermal noise emitted by the solar collector arrays. This may represent a significant broadband component of radiated power in the microwave spectrum.
- 4) Reflection by the collector arrays of high-powered transmitters in space or on the ground. This can occur over a wide range of frequencies.
- 5) Spurious emission at unwanted frequencies or in unwanted directions from the power transmitters associated with component failure of the amplifiers themselves or of parts of the antenna system. It is not certain whether failing transmitters might become unlocked in frequency, generate spurious modes or just die quietly.
- 6) Harmonics and noise generated in the rectenna.
- 7) Intermodulation between the power signal and other radio signals generated in a rectenna or in nonlinear elements in the high field areas near a rectenna.

Carrier noise, harmonics, and spurious emissions of the WPT signal must be quite small to avoid interference with other radio services in operation around the world. Grating lobes and sidelobes of the WPT beam should be low enough to make the affected region as small as possible. Also, grating lobes should be mitigated because they are a direct loss of transmitter power.

It is important that compatibility be evaluated for full systems, not just single units. Many units of 1 GW will be required if satellite solar power is to represent a significant contribution to future energy needs.

The 2.45 and 5.8 GHz ISM bands share a common frequency allocation worldwide. Familiar applications include radio controllers, microwave ovens, RF-ID (radio tags) and drying of cut lumber. To date they have been used for WPT applications for demonstration and experimental purposes.²⁵

The 2.45 GHz ISM band (2400-2500MHz) and the 5.8 GHz ISM band (5725-5875 MHz), however, have already been allocated to various other services as well. Recently, the 2.45 GHz ISM band has been widely used for Radio LAN (IEEE 802.11b and g) applications. The frequency allocation of the 2.45 GHz Radio LANs occupies almost the whole band.

The 5.8 GHz ISM band is also heavily used for various applications. The 5725-5850 MHz band is allocated to the Radiolocation service. DSRC (Dedicated Short-Range Communications), described in Recommendation ITU-R M.1543, is also expected to use the band. The 5850-5925 MHz band is allocated to Fixed/Mobile services and is used for terrestrial Electronic News Gathering (ENG) in some countries.

The second, the sixth, ninth and 20th harmonics of the 2.45 GHz ISM band overlap with radio astronomy bands (4.9-5.0, 22.1-22.5 and 48.96-49.06 GHz). It is expected that the interference level near 4.9 GHz would be very much higher (40 dB or more, depending on the system) than the harmful interference threshold. Hence the upper half, 2.45-2.5 GHz, cannot be used for SSPS.

The harmonic situation is better for the 5.8 GHz band. However, many harmonics of the 2.45 GHz and the 5.8 GHz band overlap the 76 - 116 GHz radio astronomy band.

The spurious and out-of-band (OOB) emission from high-power transmitters is likely to interfere with adjacent radio astronomy bands. Frequency allocation for SPS must avoid harmful interference with radio astronomy applications, which use very sensitive passive receivers. Spurious emissions must be suppressed sufficiently to protect the Radio Astronomy Service, and rectennas must be located far from

radio astronomy observing sites. As radio astronomy is fully passive and celestial objects have no lower limit in intensity of emission, its observing systems have been advanced to become extremely sensitive.

4.2.2 Reflection and Thermal Emission from Solar Cells^{26,24}

In the radio region, solar cells reflect solar radio emission in a continuous frequency region of 100 MHz through 100GHz and beyond. The power flux densities are 0.1 - 1 $M \times 10^{-26}$ W/m²/Hz (quiet Sun) and 100 - 1000 $M \times 10^{-26}$ W/m²/Hz (burst).

These values are six to ten orders of magnitude higher than those from typical cosmic radio sources. This means that radio astronomical observations may be affected by these reflections, depending on the telescope location on the Earth.

The apparent angular size of the solar cell array with a diameter of about 13 km is close to 1 arcminute, which is 1/30 of those of the Sun and the Moon, and a little larger than Jupiter (about 40 arcseconds), the largest planet of the solar system. Because the SPS systems are always seen at the same locations, they would prevent astronomical observations of those regions of the sky. Even the JAXA 2002 Model, for example, whose diameter of the primary mirror is about 3km (about 15 arc seconds in angular diameter), would obscure many celestial objects forever. This model system does not represent a large addition to the terrestrial power capability. The effect grows as multiple such systems are added to make an operational system.

Optical and infrared astronomy will suffer from reflection by the solar cells. This was studied extensively for the earlier US system. The National Research Council panel concluded:²⁷ "The diffuse night-sky brightness produced by the reference SPS would interfere seriously with optical astronomical measurements from the Earth. This interference would be concentrated in an area on either side of the satellite arc and would prevent the measurement of weak astronomical objects in those areas."

An important effect of the SPS on radio astronomy arises from the passive thermal radiation of the solar cells. There will be zones centered on the geostationary orbit in which observations over a wide range of frequencies will be precluded, not just at harmonics of the power transmission. For example, in the studies of the US reference system proposed in 1978, the thermal radiation from the collectors of one satellite were estimated to produce a level about 10 dB below the detrimental threshold levels of Recommendation ITU-R RA.769 assuming a unity gain antenna over a wide range of

frequencies. The interference is detrimental if one points a radio telescope so that receiving sidelobes above 10 dBi lie on the orbit. For 32-25log(ϕ) sidelobes, that means pointing closer than about ± 7.5 degrees to the orbit. There will also be noise generated in the transmitting tubes or power transistors, which could be rather wide in bandwidth if these power amplifiers are not narrow-band devices. This could be stronger than the thermal noise, but will depend on the characteristics of the particular devices used.

With a full system of satellites in orbit, satellites would be distributed fairly continuously around the GEO, so that at any radio or optical observatory a band of sky centered on the orbit would be permanently blocked from certain observations at essentially all frequencies. The substantial loss of observable sky resulting from such wideband noise emission would be severely harmful.

Such effects are, however, expected to be smaller. For example, in the case of the JAXA 2003 model shown in Fig. 2.4.9, the reflected light by the huge mirror is specific and directed to the solar cell panels and the light reflected by the cells is directed perpendicular to the direction of the Earth.

4.3 MPT on Human health and bio-effects

The concept of solar-power satellites (SPS) and wireless-power transmission (WPT) envisions the generation of electric power by solar energy in space for use on Earth.^{28,29} The system would involve placing a constellation of solar power satellites in geostationary Earth orbits. Each satellite would provide between 1 and 6 GW of power to the ground, using a 2.45 or 5.8-GHz microwave beam (see Table 2.3.2). The power-receiving rectenna on the ground would be a structure measuring 1.0 to 3.4 km in diameter. The higher (5.8 GHz) frequency has been proposed since it has a similar atmospheric transparency. Although, in principle, the higher frequency could involve a reduced size for the transmitting and receiving antennas, it can be seen from the table that current designs have opted for larger transmitting antennas and smaller rectenna sites, but a larger power density on the ground to conserve land use, especially in Japan.

A joint effort between the Department of Energy (DOE) and the National Aerospace Administration (NASA) in the US extensively investigated the feasibility of SPS-WPT during 1976-1980. The effort generated a Reference System Concept for Solar Power Satellites. The DOE-NASA Reference System involved placing a constellation of solar power satellites (5 x 10 x 0.5 km deep) in geostationary Earth orbits, each of which would provide 5-GW of power to major

cities on the ground, using a 2.45-GHz microwave beam. The Reference System's sixty satellites were contemplated to deliver a total of 300 GW of generating capacity. The transmitting antenna was about 1 km in diameter. The power-receiving rectenna on the ground was a 10 x 13-km structure.

Japan's Ministry of Economy, Trade and Industry (METI) had announced plans to launch research for a solar-power-generation satellite and to begin operating a giant solar-power station by 2040. This program is expected to design and operate an SPS-WPT system that would ensure the microwaves would not interrupt cellular mobile telephone and other wireless telecommunications services. The Japan Aerospace Exploration Agency (JAXA) has proposed and evaluated various system configurations for operation at 5.8 GHz (see Table). For example, the JAXA2 model would have a maximum power density of 100 mW/cm² (1000 W/m²) on the ground. A smaller transmitting system would have a density of 26 mW/cm² (260 W/m²) at the rectenna site on the ground.

A variety of environmental considerations and safety-related factors continue to receive consideration, albeit at a low priority level. The biological effects and health implications of microwave radiation have been a subject of study for many years.^{30,31,32} In fact, the cumulative data have allowed the establishment of recommendations for safety levels for humans under a variety of exposure conditions. For example, the ICNIRP (and Japanese) guideline is 5 or 1 mW/cm² for occupationally exposed vs. the general public, at either 2.45 or 5.8 GHz.³³ Although the corresponding limits for IEEE standards for maximum permissible human exposure to microwave radiation, at 2.45 or 5.8 GHz, are 8.16 or 10 mW/cm² averaged over six min, and 1.63 or 3.87 mW/cm² averaged over 30 min, respectively, for controlled and uncontrolled environments,³⁴ the IEEE standards have recently been changed to the similar one to that of the ICNIRP.³⁵ The controlled and uncontrolled situations are distinguished by whether the exposure takes place with or without knowledge of the exposed individual, and is normally interpreted to mean individuals who are occupationally exposed to the microwave radiation, as contrasted with the general public.

As can be seen from the Table, the proposed power densities range from 23 to 180 mW/cm² above the rectenna at the center of the microwave beam, where power densities would be maximum. At 2.45 GHz, the power density is projected to be 1 mW/cm² at the perimeter of the rectenna. Beyond the perimeter of the rectenna or 15 km,

the side lobe peaks would be less than 0.01 mW/cm². Clearly, beyond the perimeter of the rectenna, the potential exposure would be well below that currently permissible for the general public.

The danger of loss of control of highly focused beams may be minimized by tightly tuned phased-array techniques and by automatic beam defocusing to disperse the power if loss of control occurs. Defocusing would degrade the beam toward a more isotropic radiation pattern, which would give rise to even lower power density on the ground.³⁶

Near the center of the microwave beam, power densities would be greater than the permissible level of exposure for controlled situations. Except for maintenance personnel, human exposure would normally not be allowed at this location. In the case of occupationally required presence, protective measures, such as glasses, gloves and garments could be used to reduce the exposure to a permissible level.

However, at 25 mW/cm², research has shown that some birds exhibit evidence of detecting the microwave radiation. This suggests that migratory birds, flying above the rectenna, might suffer disruption of their flying paths. Moreover, at higher ambient temperatures, larger birds tend to experience more heat stress than smaller ones, during 30 min of exposure.³⁷ This result is consistent with the knowledge that the larger birds, having a larger body mass, absorb a relatively greater quantity of microwave radiation than do the smaller birds. The additional heat, from microwave energy deposited inside the body, could be stressing the thermal regulatory capacity of the larger birds. Thus to assure environmental health and safety, the proposed limit for the "center-of-beam" power densities is approximately 25 mW/cm² for microwave transmission. Note that the average absorption remains fairly stable for frequencies above 2 GHz,^{30,38} except when the frequency becomes much higher, i.e., 10 GHz, where the skin effect takes over, the maximum tolerable exposure at 5.8 GHz would be essentially the same as for 2.45 GHz.

We have to discuss the microwave (over GHz) effect on human health imposed by the SPS system. There is a long history concerning the safety of microwave energy.³⁹

Contemporary RF/microwave standards are based on the results of critical evaluations and interpretations of the relevant scientific literature. The specific absorption rate (SAR) threshold for the most sensitive effect considered potentially harmful to humans, regardless of the nature of the interaction mechanism, is used as the basis of the standard. The SAR is only related to a heating

problem, which is regarded as the only microwave effect on human health.

Discussions about the maximum microwave power density inside the rectenna site are necessary. The maximum power density depends on the antenna size and the frequency, which directly affect the total cost. In the present JAXA2 model, the microwave power density is 100 mW/cm² at the center of the rectenna site, which is above the safe level. This area should be strictly controlled. Outside of the rectenna area, the intensities are kept below the safe level. A possible change of the safe level in the future could cause changes of the SPS design.

4.4 Precautionary Principle

Any new technology has to face the "Precautionary principle." As shown in several papers,⁴⁰ the way to apply the Precautionary principle has considerably evolved. Guidelines for applications have been recommended by several administrative bodies. They are explicitly aimed at risk management. Political decisions are taken according to risks identified at a given time and to the research activities that must be pursued or undertaken. As far as the application of the SPS technology is concerned, where the main risks are environmental, it must be clear that:

- the present expertise must be used to identify and prioritize the risks, and to define critical parameters to continuously monitor in the preparation phase as well as in the operation phase, and
- complementary research programs must be set up.

If there is a recommendation from the URSI council on SPS, it will have to include the concept of the Precautionary Principle.

4.5 Summary of Pros and Cons of SPS

Arguments for promoting SPS projects have recently been re-activated due to increasing interest in clean energy. Opinions in favor of the SPS concept are based on experiment data and feasible technological arguments, while those against or suspicious of the SPS concept arise from concerns about unknown factors that might be harmful to human life or about possible strong interference with radio astronomy and existing telecommunication networks. The arguments are categorized and listed in the following two subsections. In sections 4.5.1-3, the number after 'See #' means that of the items listed in section 4.5.4. Pros and Cons of SPS in Q&A.

4.5.1 Pros of SPS

- SPS is the cleanest base-load power that can substitute for fossil fuels. [See #1.]
- SPS is one of promising solutions for the

global warming problem.

- Sustainable energy sources include wind, solar power, geo-thermals and biomass. SPS is a clean energy source that does not generate CO₂ once in operation. It is recognized the only power source that can be a base-load supplier for 24 hours among various non-atomic clean power sources. [See (2)]
- SPS is believed to contribute to reducing CO₂ emission since SPS does not generate CO₂ under operation. [See 2.1.2.]
- The incoming energy transmitted by SPS from space to the Earth is five orders of magnitude less than the total solar radiation reaching the Earth. Therefore, SPS does not worsen global warming problems. [See #8.]
- Research for microwave technologies to realize the low cost SPS should be continued.
- SPS and radio astronomy may not be completely compatible on some frequency ranges, but this is left as a choice based on future priority of sustainability of human society.

4.5.2 Cons of SPS

(1) Economics and Environment

- Construction of a huge space structure usually is expensive and takes a long time. [See 2.1.4.]
- SPS is not compatible with nor superior to current electric power sources in terms of cost. [See 2.1.4.]
- The space environment (ionosphere, magnetosphere and the ozone layer) may be damaged when the SPS power beam passes through it. [See #4, 5, 6.]

(2) Launch and Transportation

- One worries about orbit congestion and interference with the current communication satellites. Therefore, suitable room on GEO can not be given for a huge space construction like SPS. [See #12.]
- It is hard to build a huge space structure in a short period.
- Space debris may seriously damage the SPS. [See 2.3.1.]
- Some believed that the energy (and the CO₂ production) required to build, launch, and transport SPS will exceed the energy generated as a power source. [See #11.]
- The construction cost may be rather high if we use the current launching system. [See 2.1.4.]
- High construction cost and long term project result in huge budget. [See 2.1.4.]

(3) Safety and Compatibility

- SPS microwaves might be hazardous for human beings. [See #15, 16.]
- Birds in flight are subject to monochromatic microwaves. [See #13.]
- Radiation by SPS is not compatible with

radio astronomical research. [See 4.2.2.]

- SPS may interfere with other electric equipments.
- Unexpected and harmful radiation resulting from malfunctions of the SPS operation might interfere with existing telecommunications networks and airplanes. [See e.g. #16.]
- SPS should follow ITU regulations for radio astronomy observation and other uses of the spectrum, which may limit its practical application. [See #7, 18.]

4.5.3 Other issues of SPS

- Is SPS really required, and if so, when should it be introduced to our society?
- For public acceptance, the exposure level of the microwave density must be less than the safe level set by the government based on scientific research. Currently, most of the microwave power beam is designed so that the microwave density is less than 1 mW/cm² at the edge of the rectenna on the ground. Problems due to malfunctions and exposure of people on Earth and in airplanes can be avoided by highly reliable technologies.
- To operate SPS safely, precise and reliable beam control for high-power beams might be achieved with a pilot signal from the Earth. [See 4.2.1.]
- SPS should be safe for flying vehicles such as airplanes. [See #3.]
- Insects and plants should not live under rectenna. [See #14.]
- The rectenna site should be located so as to minimize interference with the existing telecommunications systems. [See 4.2.1.]
- The SPS subsystems are launched to low-earth orbit (LEO) by reusable launch vehicle (RLV), where some of the subsystems are joined and checked their basic operation. These subsystems are transported to GEO by electric propulsion orbital transfer vehicle (EOTV). It is not clear that such a complicated construction process should be employed and the largest parts of the solar cell panels may well be carried directly to GEO. [See 2.3.1.]
- Scientific findings from radio astronomy contribute to the foundation of new technologies. Telecommunications systems are essential for our daily life. Therefore SPS research should consider compatibility with them. [See 4.2]

Investigation Themes

- To show the correct economic estimation based on higher reliability
- Compatibility with the radio astronomy and the telecommunications
- Observation of change in the layers surrounding the Earth imposed by high-power beams.

4.5.4 Pros and Cons of SPS in Q&A

Presently, there are many pros and cons for SPS. Some may disappear rapidly, while others may arise in the future. Here are answers to the most frequently asked questions based on present knowledge.

● General

1. Is SPS more sustainable and cleaner energy than solar power?

Yes. Base-load power is necessary for sustainable energy. Terrestrial solar power is good for intermittent use, but it is not appropriate for base-load power. SPS can be used as a base load. The land under the rectenna would be available for agriculture. See, 2.1.3.

● Economics and Environment

2. Is SPS expensive?

Power generation cost could be competitive or cheaper than other energy sources. This will require reduction of launch costs by very large factors. Innovative technologies, especially radio wave technologies, have to be developed in order to reduce the SPS cost. See, 2.1.4.

3. Is SPS hazardous to airplanes?

Yes, the power density at the SPS beam center is above the regulation of US Federal Aviation Administration (FAA). This area should be placed off limits to air traffic control.

4. Does SPS affect shortwave propagation in the ionosphere?

Nonlinear effects in the ionosphere at the SPS microwave intensities are expected in the center of the beam only. If shortwave propagation is affected it would be limited to that region. See 4.1.2.

5. Does SPS affect the atmospheric chemistry, the ozone layer, and more generally on the climate?

There would be no effects. See 4.1.1.

6. Will ion engines destroy the ozone layer?

Hardly. Hydrogen chloride used by solid rockets could destroy the ozone layer. However, SPS will be transferred by Reusable Launch Vehicles (RLVs) in stead of solid rockets. RLVs use liquid hydrogen and oxygen. Their destruction of the ozone layer is expected to be very small.

7. Does SPS change the night sky?

Angular size of the solar cells or mirrors assumed in the recent SPS models is smaller than that of Jupiter. The reflected direction is limited since the mirrors cause an almost *specular* reflection. See 4.2. If a huge number of SPS are orbited, more effects would occur.

8. Does sending energy from outside the Earth worsen global warming?

No. The power density of the beam is weaker than that of sunlight. The total energy used on the Earth is only 1/7000 of the amount of the solar

energy reaching the Earth. Since the efficiency of rectenna is quite high, the amount of heat radiation is very small and no CO₂ is emitted.

9. Will SPS become huge debris?

Present usage in GEO is to move satellites above GEO by several hundred km following end of life. Most parts of SPS, however, should be used multiple times in further SPS generations. The rest should be brought back to the Earth.

10. Could the microwave beams become weapons?

No. The maximum power density can never exceed the designed level. Microwave weapons will use high-power pulses at short ranges. Its design is quite different from SPS design. See 4.3.

11. Is more energy used to construct SPS than is obtainable from it?

No. The period to recover the energy for construction (energy pay-back time) is less than one year.

● Launch and Transportation

12. There is no space in Geostationary Earth Orbits.

If spectrum congestion were negligible, satellites would only require separation of about 64 km.⁴¹ This corresponds to 0.1° spacing. The spectra of signal interference, however, has led regulators to mandate orbital separations of from 1,280 to 2,560 km (2 to 4° spacing) or more in order to avoid signal interference among neighboring communications satellites using the same frequencies. SPS could be operated with less separation. There have not yet been adequate studies of the required separation between SPS and communication satellites.

● Safety and Compatibility

13. Are entire migratory flocks of birds cooked or at least influenced en route?

They are never cooked. The reporting is generally for power densities higher than the 23 mW/cm² peak in the center of the baseline SPS beam. It appears that the 23 mW/cm² power density did not disturb the birds much, but doubling that power density would strongly affect the birds.⁴²

14. Are insects affected by SPS?

No evidence has been found that 2.45 GHz continuous wave microwaves at selected power densities from 1 to 50 mW/cm² have biological effects on honey bees.

15. Is SPS safe?

According to our present knowledge, yes. The power density of the microwave beam is within the safe level at the perimeter of the rectenna site. See 4.3. Conservative government safety guidelines allow microwave ovens to leak 5 mW/cm². The allowable leak level in Japan is 1 mW/cm² at 5 cm from the oven.

16. Is SPS beam harmful if directed in the wrong direction?

If the direction deviates from the rectenna site, the beam is defocused and its intensity becomes very low. See 3.2.3. However, accidental or intentional redirection may be possible through the control software.

17. Does SPS interfere with communications?

Probably. Needless to say, grating lobes and sidelobes of the MPT beams and harmonics and spurious emissions should be suppressed to avoid possible interference with communications. See 4.2.

18. Does SPS interfere with radio astronomy?

Probably. Undesired emissions of the MPT beams should be suppressed sufficiently to avoid interference with radio astronomy in accordance with the provisions of the ITU-R Radio Regulations. See 4.2.

¹ Recommendation ITU-R P.837-4, Characteristics of precipitation for propagation modeling, ITU, 2003.

² G. Maral and M. Bousquet, Satellite communications systems, 3rd Ed., John Wiley & Sons, 1993.

³ Furuhashi, R., and S. Ito, Effects of high power microwave propagation to ionized atmosphere (in Japanese), Review of the Radio Research Laboratories, Vol. 28, No. 148, 715-721, 1982.

⁴ Batanov, G. M., Batanov, I. A. Kossyi, and V. P. Silakov, Plasma Physics Reports, Vol. 28, No. 3, 2002, pp. 204-228. (Translated from Fizika Plazmy, Vol. 28, No. 3, 2002, pp. 229-256.) Negative effects were first discussed by their group (G.A. Askar'yan, G.M. Batanov, I.A. Kossyi, and A. Yu Kostinskii, Sov. J. Plasma Phys., 17(1), 48-55, January 1991) but they changed their idea from negative to positive.

⁵ Perkins, F. W. and R. G. Roble, Ionospheric heating by radio waves: Predictions for Arecibo and the satellite power station, J. Geophys. Res., 83, A4, 1611-1624, 1978.

⁶ Stubbe, P., Modifying effects of a strong electromagnetic wave upon a weakly ionized plasma: a kinetic description, Radio Sci., 16, 3, 417-425, 1981.

⁷ Matsumoto et al., Rocket experiment on non-linear interaction of high power microwave energy beam with the ionosphere: Project MINIX toward the solar power satellite, ISAS Space Energy Symposium, 69-76, 1982.

⁸ Rietveld, M. T., Ground and in situ excitation of waves in the ionospheric plasma, J. Atmos. Terr. Phys., 47, 12, 1283-1296, 1985 (review of poster paper presented at URSI General Assembly, Florence, 1984)

⁹ Stubbe, P., H. Kopka, M. T. Rietveld, and R. L. Dowden, ELF and VLF wave generation by modulated heating of the current carrying lower ionosphere, J. Atmos. Terr. Phys., 44, 12, 1123-1135, 1982.

¹⁰ Chilson, P. B., E. Belova, M. T. Rietveld, S. Kirkwood, U.-P. Hoppe, First artificially induced

- modulation of PMSE using the EISCAT heating facility, *Geophys. Res. Lett.*, 27, 23, 3801-3804, 2000.
- ¹¹ Havnes, O., C. La Hoz, L. I. Naesheim, M. T. Rietveld, First observations of the PMSE overshoot effect and its use for investigating the conditions in the summer mesosphere, *Geophys. Res. Lett.* 30, 23, 2229, doi:10.1029/2003GL018429, 2003.
- ¹² Kero, A., T. Bösinger, P. Pollari, E. Turunen and M. Rietveld, First EISCAT measurement of electron-gas temperature in the artificially heated D-region ionosphere, *Ann. Geophysicae*, 18, 9, 1210-1215, 2000.
- ¹³ Matsumoto, H., Numerical estimation of SPS microwave impact on ionospheric environment, *Acta Astronautica*, 9, 8, 493-497, 1982.
- ¹⁴ Dysthe, K. B.; Mjølhus, E.; Trulsen, J. Nonlinear mixing in the ionosphere, *Physica Scripta*, 21, 122-128, 1980.
- ¹⁵ Cerisier, J. C., Lavergnat, J.; Rihouey, J. J.; Pellat, R. Generation of Langmuir waves by nonlinear wave-wave interaction in the ionosphere, *J. Geophys. Res.*, 86, 4731-4738, 1981.
- ¹⁶ Lavergnat, J., P. Bauer, J. Y. Delahaye, and R. Ney, Nonlinear sounding of the ionospheric plasma, *Geophys. Res. Lett.*, 4, 417-420, 1977.
- ¹⁷ Matsumoto, H., Microwave power transmission from space and related nonlinear plasma effects, *Radio Science Bulletin*, no. 273, pp. 11-35, June, 1995.
- ¹⁸ Matsumoto, H., H. Hirata, Y. Hashino, N. Shinohara, Theoretical analysis of nonlinear interaction of intense electromagnetic wave and plasma waves in the ionosphere, *Electronics and Communications in Japan*, Part3, 78, 11, 104-114, 1995b.
- ¹⁹ Matsumoto, H., Y. Hashino, H. Yashiro, N. Shinohara, Computer Simulation on Nonlinear interaction of Intense Microwaves with Space plasmas, *Electronics and Communications in Japan*, Part3, 78, 11, 89-103, 1995a
- ²⁰ Chiu, Y. T., Fate of Argon ion injection in the magnetosphere, *AIAA Paper* 80-0891, 1980.
- ²¹ Curtis, S. A., and Grebowsky, J. M., Energetic ion beam magnetosphere injection and solar powered satellite transport, *J. Geophys. Res.*, Vol. 85, No. A4, 1729-1735, 1980.
- ²² Y. Omura T. Sakakima, H. Usui, and H. Matsumoto, Computer experiments on interaction of heavy ion beam from a large-scale ion engine with magnetospheric plasma, *IUGG 2003, Sapporo*, (2003).
- ²³ T. Hatsuda, K. Ueno, M. Inoue, Solar power satellite interference assessment, *IEEE Microwave Magazine*, Vol. 3, No. 4, 65-70, December, 2002
- ²⁴ A. R. Thompson, Effects of a satellite power system on ground-based radio and radar astronomy, *Radio Science*, 16, 35-45, 1981.
- ²⁵ Present status of wireless power transmission toward space experiments, *Document No. IA/53-E, Task Group ITU-R WPIA, Question 210/1*, ITU Radiocommunication Study Group, October 1, 2004.
- ²⁶ Radiocommunication Study Group Document WP7D, submitted by Japan, February 1996.
- ²⁷ *Electric Power from Orbit, a Critique of a Satellite Power System*, National Academy Press, Washington, D.C. 1981
- ²⁸ National Research Council, 2001, *Laying the Foundation for Space Solar Power: An Assessment of NASA's Space Solar Power Investment Strategy*, National Research Council, Washington, D.C.
- ²⁹ Lin, J, "Space Solar-Power Stations, Wireless Power Transmissions, and Biological Implications", *IEEE Microwave Magazine*, pp. 36-42, March 2002.
- ³⁰ Michaelson, S. and J.C. Lin, 1987, *Biological Effects and Health Implications of Radiofrequency Radiation*, Plenum Press, New York.
- ³¹ Lin, J.C., "Biological Aspects of Mobile Communication Fields," *Wireless Networks*, vol. 3, pp 439-453, 1997.
- ³² Lin, J.C., "Biological Effects of Microwave Radiation," In *Electricity and Magnetism in Biology and Medicine*. F. Bersani, ed., Kluwer/Plenum, New York, pp 165-169, 1999.
- ³³ ICNIRP, "Guidelines for Limiting Exposure to Time-varying Electric, Magnetic, and Electromagnetic Fields (Up to 300 GHz)," *Health Physics*, 74, 1998, pp. 494-522.
- ³⁴ IEEE, Standard for Safety Levels with Respect to Human Exposure to Radio Frequency Electromagnetic Fields, 3 kHz to 300 GHz, IEEE, New York, 1999.
- ³⁵ Lin, J.C.. The New IEEE Standard for Human Exposure to Radio-Frequency Radiation and the Current ICNIRP Guidelines, *Radio Science Bulletin*, No. 317, 61-63, June, 2006.
- ³⁶ Osepchuk, J.M., Health and Safety Issues for Microwave Power Transmission, *Solar Energy*, 56:53-60, 1996.
- ³⁷ U.S. DOE, Proceedings of Solar Power Satellite Program Review, Office of Energy Research, Department of Energy, Washington, D.C., 1980.
- ³⁸ Lin, J.C. and O.P. Gandhi, "Computer Methods for Predicting Field Intensity," in *Handbook of Biological Effects of Electromagnetic Fields*, (C. Polk and E. Postow, Eds.), CRC Press, Boca Raton, pp 337-402, 1996.
- ³⁹ John M. Osepchuk and Ronald C. Petersen, "Historical Review of RF Exposure Standards and the International Committee on Electromagnetic Safety (ICES)", *Bioelectromagnetics Supplement* 6:S7-S16, 2003.
- ⁴⁰ see for instance Foster et al., 2000, http://www.biotech-info.net/science_and_PP.html
- ⁴¹ M.K. Macauley, Allocation of Orbit and Spectrum Resources for Regional Communications: What's at Stake? Discussion Paper 98-10, Resources for the future, December 1997 www.rff.org/Documents/RFF-DP-98-10.pdf
- ⁴² <http://www.permanent.com/p-sps-bm.htm> See also, R. Dickinson, "Estimated Avian Temperature Rise During Flyover of a 5.8 GHz Wireless Power Transmission Beamer," WPT-2001, La Reunion Island, France, May 14-17, 2001.

Chapter 5 URSI and SPS

5.1 Technologies

The International Union of Radio Science (Union Radio-Scientifique Internationale), a non-governmental and non-profit organization under the International Council for Science, is responsible for stimulating and coordinating, on an international basis, studies, research, applications, scientific exchange, and communication in the fields of radio science. Let us look at the relation of the SPS technologies with Terms of Reference of the URSI Scientific Commissions listed in Appendix of the White Paper. Various technical issues closely related to terms of specific Commissions are described below.

Commission D (Electronics and photonics) promotes research in electronic devices, circuits, systems and applications, and it has a broad interest in SPS, particularly in MPT. Substantial technological areas covered by the Commission have direct relevance to MPT. Many other emerging areas related to the Commission have significant potential for enhancing existing MPT technology. More correctly, a task of Commission D scientists and engineers is to find the deficiencies of the existing technology and to envision potential technologies to rectify the present shortcomings. In addition, since Commission D is closely related to devices and high frequency component industries, manufacturability should be an important criteria in assessing the particular technology for MPT. Since SPS requires huge investments even for the electronic parts, the availability of particular materials and the manufacturability are of serious concerns.

Commission D scientists and engineers can play important roles in microwave power generation, beam control and efficient power recovery as well as related technologies on microwave devices, circuits and systems. These activities are also related to antenna technologies primarily addressed by Commission B.

Examples to be developed are highly efficient power transmitters with low harmonics, low-loss phase shifters, and diodes for efficient rectennas at low power.

The interest of Commission B (Fields and waves) is fields and waves, encompassing theory, analysis, computation, experiments, and validation of fields and waves. One of the areas of emphasis is antennas and radiation. A huge antenna array is essential for microwave transmission from the SPS. High transmission efficiency (the ratio of the received power to the transmitted power) is required. The suppression of grating lobes and side-lobes must be suppressed to avoid interference with communications and to guarantee bio-safety. This can be achieved by tapering the output power distribution in the antenna array.

Microwave measurements and calibrations are necessary to evaluate power, interference, and spurious emissions from the SPS and the rectennas. Contributions from Commission A (Electromagnetic metrology) are expected. The Commission promotes research and development of measurements and standards in time and frequency, including infrared and optical frequencies, in

the time domain, in the frequency domain, in telecommunications, etc.

Direction finding and self-calibration systems should be developed to calibrate the SPS antenna array with its huge number of elements. These issues require signal processing techniques studied in Commission C (Radio communication systems and signal processing), which promotes research and development in Signal and Image Processing in the area of radio science.

5.2 Environments

Atmospheric effects, including the ozonosphere, produced by and imposed on microwave beams, linear and nonlinear interactions with the ionosphere and space plasma of the microwave beam should be evaluated through theories, experiments and computer simulations. (Commissions F, Wave propagation and remote sensing; G, Ionospheric radio and propagation; and H, Waves in plasmas) In SPS construction, a huge amount of materials must be transferred from Low-Earth Orbit (LEO) to Geostationary Earth Orbit (GEO) by electric propulsion where accelerated ions are ejected from ion engines. The interaction of the heavy ions with the surrounding plasma could change the electromagnetic environment of the magnetosphere. These plasma processes is quantitatively evaluated (Commission H, which includes the areas of solar/planetary plasma interactions).

Most SPS systems are assumed to use the frequencies of 2400 to 2500 MHz or 5725 to 5875 MHz for MPT. Compatibility of SPS with radio communications and radio astronomy are important issues for URSI. (Commission E, Electromagnetic noise and interference; and Commission J, Radio astronomy)

The evaluation of possible effects on human health and bio-effects by microwaves transmitted from SPS is essential for public acceptance. (Commission K, Electromagnetics in biology and medicine)

Chapter 6 Further Readings

(1) A recent text book on SPS is **P. E. Glaser, F. P. Davidson, K. I. Csigi, Eds., Solar Power Satellites (Wiley-Praxis, New York, 1997)**. This is composed of five parts, The solar power satellite concept Perceptions about energy for planet Earth civilization, International SPS-related activities, Earth-based and space-based infrastructure considerations, and SPS development, and covers a wide range of topics on SPS useful for the general public.

<http://www.praxis-publishing.co.uk/view.asp?id=64&search=home>

(2) A review by **National Research Council** is published in **“Laying the Foundation for Space Solar Power: An Assessment of NASA’s Space Solar Power Investment Strategy” (National Academy Press, Washington, D.C., 2001)**. The U.S. Congress became interested in SSP and in FY 1999 appropriated funds for NASA to conduct the SSP Exploratory Research and Technology (SERT) program. The SERT program and its follow-on, the SSP Research and Technology (SSP R&T) program, constitute the effort assessed in this report. <http://search.nap.edu/books/0309075971/html/>

(3) AP-RASC (Asia-pacific radio science) meeting was held in Tokyo, Japan, in August 2001. This conference was sponsored by the Japanese National Committee of URSI (the International Union of Radio Science) and The Institute of Electronics, Information and Communication Engineers (IEICE) in Japan and cosponsored by URSI. A selection of papers presented at the Union Session was entitled “Solar Power Satellite and Wireless Power Transmission,” were published in a **special section of the IEEE Microwave Magazine, vol. 3, no. 4, December 2002**. The four papers cover SPS research in Japan and the US, health and interference issues.

<http://ieeexplore.ieee.org/xpl/tocresult.jsp?isYear=2002&isnumber=25789&Submit32=Go+To+Issue>

(4) **A two-part Special Section on Space Solar Power Systems (SSPS) was published in the Radio Science Bulletin, nos. 310 and 311, in September and December 2004**. The eleven papers in the section are based on the invited talks at the 2003 Japan-United States Joint Work Shop on Space Solar Power Systems (JUSPS’03) held on July 3-4, 2003, at Kyoto University, Japan. These papers cover an SPS demonstration experiment, microwave semiconductor, tube, and nano- and micro-devices; passive and active antennas; power combiners; and retrodirective systems. They are available via the following URSI website.

<http://www.ursi.org/RSBissues/RSBSept2004.PDF>

<http://www.ursi.org/RSBissues/RSBdecember2004.PDF>

(5) History of Microwave Power Transmission

The following papers are recommended for the understanding of MPT.

1. W. C. Brown, The history of power transmission by radio waves, IEEE Trans. Microwave Theory and Techniques, MTT-32, pp.1230-1242, 1984.
2. W. C. Brown, The history of wireless power transmission, Solar Energy, vol. 56, 3-21, 1996.

3. H. Matsumoto, Microwave power transmission from space and related nonlinear plasma effects, Radio Science Bulletin, no. 273, pp. 11-35, June, 1995.

(6) **Space Solar Power Workshop** (<http://www.sspi.gatech.edu/>) is a continuing conceptual design of how to build, finance, deliver, market, support, operate, and maintain an Space Solar Power System for the world base load energy market. A book, "Silent Power", summarizing the work of the SSPW to date will be published here.

Some examples of SF (science fiction) books that treat SPS are as follows.

(7) **Ben Bova, Powersat, has been published in 2005**. Two hundred thousand feet up, things go horribly wrong. An experimental low-orbit spaceplane breaks up on reentry, falling to Earth over a trail hundreds of miles long. Its wake is the beginning of the most important mission in the history of space. America needs energy, and Dan Randolph is determined to give it to them. He dreams of an array of geosynchronous powersats, satellites that gather solar energy and beam it to generators on Earth, freeing America from its addiction to fossil fuels and breaking the power of the oil cartels forever. But the wreck of the spaceplane has left his company, Astro Manufacturing, on the edge of bankruptcy.

<http://b00ks.bankhacker.com/Powersat+%28The+Grand+Tour%29/>

(8) **Isaac Asimov, How Did We Find Out About Solar Power? published in 1981**. Ever since the first person sat in the sun to get warm, we’ve been tapping solar energy. The ancient Romans discovered how to trap the Sun’s warmth in glass "greenhouses" for growing plants. But it wasn’t until modern times that people began to search for ways to use the Sun’s light and warmth at home. As the costs of other fuels rise, the search for solar power continues on Earth, but its solution may lie in outer space!

<http://homepage.mac.com/jhjenkins/Asimov/Books/Book230.html>