

INTERNATIONAL
UNION OF
RADIO SCIENCE

UNION
RADIO-SCIENTIFIQUE
INTERNATIONALE

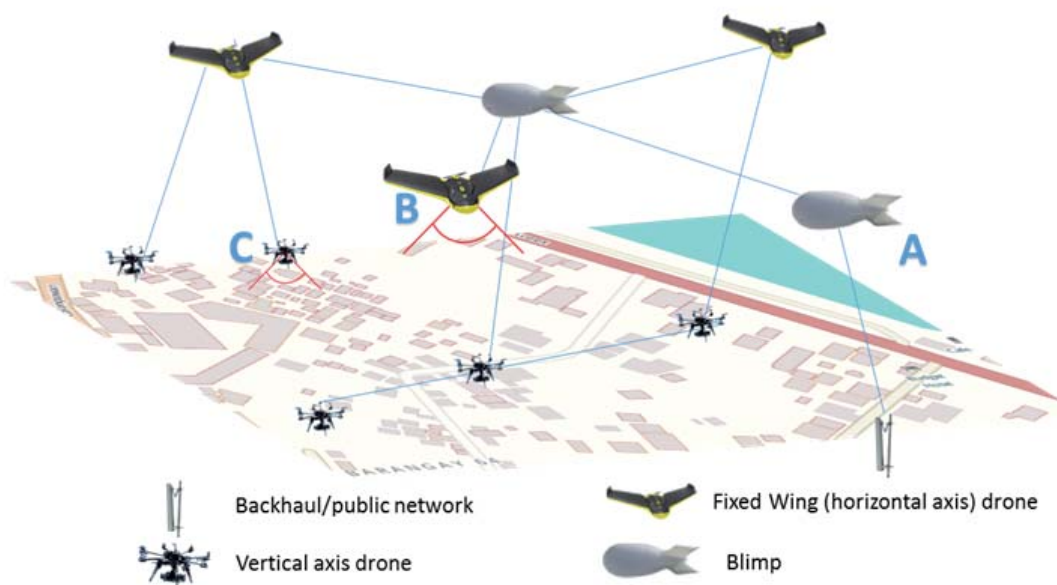
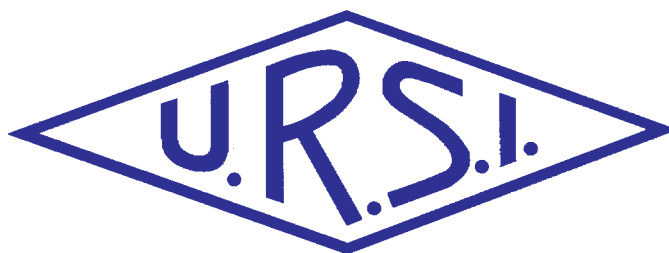

No 355
December 2015

URSI, c/o Ghent University (INTEC)
St.-Pietersnieuwstraat 41, B-9000 Gent (Belgium)

Contents

Radio Science Bulletin Staff	3
URSI Officers and Secretariat	6
Editor’s Comments	8
URSI AP-RASC 2016	10
Introduction to Special Section on Disaster Management	11
Some Thoughts on Disaster Management	13
DEMETER Results Related to Seismic Activity	18
Topology Control of a Network of Autonomous Aerial Drones	26
Designing Autonomous Crawling Equipment to Detect Personal Connected Devices and Support Rescue Operations: Technical and Societal Concerns ..	35
Calibration Procedures for Global Precipitation-Measurement Ground-Validation Radars	45
Et Cetera	74
Early Career Representative Column	75
Historical Column	78
Book Reviews	90
16th International Conference on Mathematical Methods in Electromagnetic Theory	91
IEEE RADIO 2015	92
The James Clerk Maxwell Foundation	93
USNC-URSI 2016 National Radio Science Meeting SPC	94
Conference Calendar	95
International Geophysical Calendar 2016	97
List of URSI Officials	104
Alphabetical Index and Co-ordinates	114
Information for Authors	135

Front cover: “An example of the deployment of a mission-based airborne network”. See the paper by Daniel Camara, pp. 26-34.

The International Union of Radio Science (URSI) is a foundation Union (1919) of the International Council of Scientific Unions as direct and immediate successor of the Commission Internationale de Télégraphie Sans Fil which dates from 1914.

Unless marked otherwise, all material in this issue is under copyright © 2015 by Radio Science Press, Belgium, acting as agent and trustee for the International Union of Radio Science (URSI). All rights reserved. Radio science researchers and instructors are permitted to copy, for non-commercial use without fee and with credit to the source, material covered by such (URSI) copyright. Permission to use author-copyrighted material must be obtained from the authors concerned.

The articles published in the Radio Science Bulletin reflect the authors’ opinions and are published as presented. Their inclusion in this publication does not necessarily constitute endorsement by the publisher.

Neither URSI, nor Radio Science Press, nor its contributors accept liability for errors or consequential damages.

Radio Science Bulletin Staff

Editor

W. R. Stone

Stoneware Limited
840 Armada Terrace
San Diego, CA 92106, USA
Tel: +1-619 222 1915, Fax: +1-619 222 1606
E-mail: r.stone@ieee.org

Editor-in-Chief

P. Lagasse

URSI c/o INTEC
Ghent University
Sint-Pietersnieuwstraat 41
B-9000 Gent, BELGIUM
Tel: +32 9-264 33 20, Fax: +32 9-264 42 88
E-mail: lagasse@intec.ugent.be

Production Editors

I. Lievens

I. Heleu
URSI, c/o INTEC
Sint-Pietersnieuwstraat 41
B-9000 Gent, BELGIUM
Tel: +32 9-264.33.20, Fax: +32 9-264.42.88
E-mail: ingeursi@intec.ugent.be, info@ursi.org

Senior Associate Editors

A. Pellinen-Wannberg

Department of Physics
Umea University
BOX 812
SE-90187 Umea, SWEDEN
Tel: +46 90 786 74 92, Fax: +46 90 786 66 76
E-mail: asta.pellinen-wannberg@umu.se

O. Santolik

Institute of Atmospheric Physics
Academy of Sciences of the Czech Republic
Bocni II
1401, 141 31 Prague 4, CZECH REPUBLIC
Tel: +420 267 103 083, Fax +420 272 762 528
E-mail os@ufa.cas.cz, santolik@gmail.com

Associate Editors, Commissions

Commission A

P. Tavella

INRIM
Strada delle Cacce 91
10135 Torino, ITALY
Tel: +39 011 3919235, Fax: +39 011 3919259
E-mail: tavella@inrim.it

P. M. Duarte Cruz

Instituto de Telecomunicações
Campus Universitário de Santiago
P-3810-193 Aveiro, PORTUGAL
Tel: +351 234377900
E-mail: pcruez@av.it.pt

Commission B

K. Kobayashi

Dept. of Electrical, and Communication Engineering
Chuo University
1-13-27 Kasuga, Bunkyo-ku
Tokyo, 112-8551, JAPAN
Tel: +81 3 3817 1846/69, Fax: +81 3 3817 1847
E-mail: kazuya@tamacc.chuo-u.ac.jp

L. Li

School of EECS
Peking University
Room 2843N, Science Building#2
Beijing 100871, CHINA CIE
Tel: +86-10-62754409-2, Fax: +86-10-62754409
E-mail: lianlin.li@pku.edu.cn

Commission C

S. E. El-Khamy

Dept. of Electrical Engineering
Alexandria University - Faculty of Engineering
Abou-Keer Street
Alexandria 21544, EGYPT
Tel: +2010-1497360, Fax: +203 5971853
E-mail: elkhamy@ieee.org, said.elkhamy@gmail.com

A. I. Zaghloul

Ece, Virginia Tech
7054 Haycock Rd
22043 Falls Church, USA
Tel: +1-703-538-8435, Fax: +1-703-538-8450
E-mail: amirz@vt.edu

Commission D

G. Gradoni

School of Mathematical Sciences
University of Nottingham
University Park
Nottingham NG7 2RD, UNITED KINGDOM
Tel: +44(0)7745368300, Fax: +44(0)1159514951
E-mail: gabriele.gradoni@gmail.com, gabriele.gradoni@nottingham.ac.uk

Commission E

F. Gronwald

Hamburg University of Technology
Harburger Schloss Strasse 20
21079 Hamburg, GERMANY
Tel: +49-40-42878-2177
E-mail: gronwald@tuhh.de

G. Gradoni

School of Mathematical Sciences
University of Nottingham
University Park
Nottingham NG7 2RD, UNITED KINGDOM
Tel: +44(0)7745368300, Fax: +44(0)1159514951
E-mail: gabriele.gradoni@gmail.com, gabriele.gradoni@nottingham.ac.uk

Commission F

V. Chandrasekar

Engineering B117
Colorado State University
Fort Collins, Colorado 80523, USA
Tel: +1 970 491 7981, Fax: +1 970 491 2249
E-mail: chandra@engr.colostate.edu, chandra.ve@gmail.com

M. Kurum

Department of Electrical and Computer Engineering
The George Washington University
800 22nd Street
NW, Washington, DC 20052, USA
Tel: +1 202 994 6080
E-mail: mkurum@gmail.com

Commission G

P. Doherty

Institute for Scientific Research
Boston College
140 Commonwealth Avenue
Chestnut Hill, MA 02467, USA
Tel: +1 617 552 8767, Fax: +1 617 552 2818
E-mail: Patricia.Doherty@bc.edu

Commission H

J. Lichtenberger

Eötvös University
Pazmany Peter Setany 1/a
H-1111 Budeapest
HUNGARY
Tel: +36 1 209 0555 x6654, Fax +36 1 372 2927
E-mail lityi@sas.elte.hu

W. Li

UCLA
7127 Math Sciences Bldg
405 Hilgard Avenue
Los Angeles, CA, 90095, USA
E-mail: moonli@atmos.ucla.edu

Commission J

J. W. M. Baars

Mm-astronomy
Max Planck Institute for Radio Astronomy
Auf dem Hügel 69
53121 Bonn, GERMANY
Tel: +49-228-525303
E-mail: jacobbaars@arcor.de

Commission K

P. Mojabi

Room E3-504B, EITC Building
Electrical and Computer Engineering Department
University of Manitoba
Winnipeg, R3T5V6, CANADA
Tel: +1 204 474 6754, Fax: +1 204 261 4639
E-mail: Puyan.Mojabi@umanitoba.ca

Associate Editors, Columns

Book Reviews

G. Trichopoulos

Electrical, Computer & Energy Engineering ISTB4 555D
Arizona State University
781 E Terrace Road, Tempe, AZ, 85287 USA
Tel: +1 (614) 364-2090
E-mail: gtrichop@asu.edu

Solution Box

Ö. Ergül

Department of Electrical and Electronics Engineering
Middle East Technical University
TR-06800, Ankara, Turkey
E-mail: ozgur.ergul@eee.metu.edu.tr

Historical Papers

J. D. Mathews

Communications and Space Sciences Lab (CSSL)
The Pennsylvania State University
323A, EE East
University Park, PA 16802-2707, USA
Tel: +1(814) 777-5875, Fax: +1 814 863 8457
E-mail: JDMathews@psu.edu

Telecommunications Health & Safety

J. C. Lin

University of Illinois at Chicago
851 South Morgan Street, M/C 154
Chicago, IL 60607-7053 USA
Tel: +1 312 413 1052, Fax: +1 312 996 6465
E-mail: lin@uic.edu

Et Cetera

T. Akgül

Dept. of Electronics and Communications Engineering
Telecommunications Division
Istanbul Technical University
80626 Maslak Istanbul, TURKEY
Tel: +90 212 285 3605, Fax: +90 212 285 3565
E-mail: tayfun.akgul@ieec.org

Historical Column

G. Pelosi

Department of Information Engineering
University of Florence
Via di S. Marta, 3, 50139 Florence, Italy
E-mail: giuseppe.pelosi@unifi.it

Women in Radio Science

A. Pellinen-Wannberg

Department of Physics and Swedish Institute of Space
Physics
Umeå University
S-90187 Umeå, Sweden
Tel: +46 90 786 7492
E-mail: asta.pellinen-wannberg@umu.se

Early Career Representative Column

S. J. Wijnholds

Netherlands Institute for Radio Astronomy
Oude Hoogeveensedijk 4
7991 PD Dwingeloo, The Netherlands
E-mail: wijnholds@astron.nl

URSI Officers and Secretariat

Current Officers triennium 2014-2017



President

P. S. Cannon
Gisbert Kapp Building
University of Birmingham
Edgbaston, Birmingham, B15 2TT,
UNITED KINGDOM
Tel: +44 (0) 7990 564772
Fax: +44 (0)121 414 4323
E-mail: p.cannon@bham.ac.uk
president@ursi.org



Vice President

M. Ando
Dept. of Electrical & Electronic Eng.
Graduate School of Science and Eng.
Tokyo Institute of Technology
S3-19, 2-12-1 O-okayama, Meguro
Tokyo 152-8552
JAPAN
Tel: +81 3 5734-2563
Fax: +81 3 5734-2901
E-mail: mando@antenna.ee.titech.ac.jp



Past President

P. Wilkinson
Bureau of Meteorology
P.O. Box 1386
Haymarket, NSW 1240
AUSTRALIA
Tel: +61 2-9213 8003
Fax: +61 2-9213 8060
E-mail: p.wilkinson@bom.gov.au



Vice President

Y. M. M. Antar
Electrical Engineering Department
Royal Military College
POB 17000, Station Forces
Kingston, ON K7K 7B4
CANADA
Tel: +1-613 541-6000 ext.6403
Fax: +1-613 544-8107
E-mail: antar-y@rmc.ca



Secretary General

P. Lagasse
URSI c/o INTEC
Ghent University
Sint-Pietersnieuwstraat 41
B-9000 GENT
BELGIUM
Tel: +32 9-264 33 20
Fax: +32 9-264 42 88
E-mail: lagasse@intec.ugent.be



Vice President

U. S. Inan
Director, STAR Laboratory
Electrical Eng. Dept
Stanford University
Packard Bldg. Rm. 355
350 Serra Mall
Stanford, CA 94305, USA
Tel: +1-650 723-4994
Fax: +1-650 723-9251
E-mail: inan@stanford.edu
uinan@ku.edu.tr



Vice President

S. Ananthkrishnan
Electronic Science Department
Pune University
Ganeshkhind, Pune 411007
INDIA
Tel: +91 20 2569 9841
Fax: +91 20 6521 4552
E-mail: subra.anan@gmail.com

URSI Secretariat



Secretary General

P. Lagasse
URSI c/o INTEC
Ghent University
Sint-Pietersnieuwstraat 41
B-9000 Gent
BELGIUM
Tel: +32 9-264 33 20
Fax: +32 9-264 42 88
E-mail: lagasse@intec.ugent.be



Assistant Secretary General AP-RASC

K. Kobayashi
Dept. of Electr and Commun. Eng.
Chuo University
1-13-27 Kasuga, Bunkyo-ku
Tokyo, 112-8551
JAPAN
Tel: +81 3 3817 1846/69
Fax: +81 3 3817 1847



Assistant Secretary General

P. Van Daele
INTEC- IBBT
Ghent University
Gaston Crommenlaan 8 bus 201
B-9050 GENT
BELGIUM
Tel: +32 9 331 49 06
Fax +32 9 331 48 99
E-mail peter.vandaele@intec.Ugent.be



Executive Secretary

I. Heleu
URSI, c/o INTEC
Sint-Pietersnieuwstraat 41
B-9000 Gent
BELGIUM
Tel. +32 9-264.33.20
Fax +32 9-264.42.88
E-mail info@ursi.org



Assistant Secretary General Publications

W.R. Stone
840 Armada Terrace
San Diego, CA 92106
USA
Tel: +1-619 222 1915
Fax: +1-619 222 1606
E-mail: r.stone@ieee.org



Administrative Secretary

I. Lievens
URSI, c/o INTEC,
Sint-Pietersnieuwstraat 41
B-9000 Gent
BELGIUM
Tel: +32 9-264.33.20
Fax: +32 9-264.42.88
E-mail: ingeursi@intec.ugent.be



Assistant Secretary General AT-RASC

P. L. E. Uslenghi
Dept. of ECE (MC 154)
University of Illinois at Chicago 851
S. Morgan Street
Chicago, IL 60607-7053
USA
Tel: +1 312 996-6059
Fax: +1 312 996 8664
E-mail: uslenghi@uic.edu

Editor's Comments



Ross Stone

Stoneware Limited
840 Armada Terrace
San Diego, CA 92106, USA
Tel: +1-619 222 1915, Fax: +1-619 222 1606
E-mail: r.stone@ieee.org

Special Section on Disaster Management

Our December issue begins with a “Special Section on Disaster Management,” guest edited by Tullio Tanzi. Radio science can play a significant role in mitigating the effects of both natural and manmade disasters before, during, and after their occurrence. This includes the science of most of the Commissions of URSI, and it is one of the clearest ways in which radio science has a direct positive impact on society. The first paper in the special section, by Tullio Tanzi, looks at the objectives of disaster management and the role of radio science. Ethical, legal, and social considerations are also discussed. The second paper, by Michel Parrot and Mei Li, presents a summary of what has been learned from the DEMETER micro-satellite investigations of ionospheric perturbations related to seismic activity. These results suggested the possibility of perhaps being able to develop a system that might provide very-short-term but highly useful warnings of significant seismic events. Daniel Camara’s paper looks at the use of a fleet of autonomous fully automated aerial drones for disaster-relief efforts. Approaches to the management and control of such a fleet are described. Finally, Tullio Tanzi, Olivier Sebastien, and Caroline Rizza consider the use of autonomous crawling devices to detect personal electronic equipment (e.g., cell phones) as a method of locating survivors in disasters. In addition to technical issues associated with the use of such drones, the authors consider the ethical, legal, and social issues involved in their use. Please see the introduction to the special section for a more-complete discussion of the special section.

The efforts of Tullio Tanzi and the authors of these invited papers are gratefully acknowledged.

A “Handbook” on Radar Calibration

V. Chandrasekar, Luca Baldini, Nitin Bharadwaj, and Paul Smith have provided us with a most interesting paper providing what amounts to a handbook on the calibration of weather radars. While comprehensive in scope, this paper is also written so that it is tutorial in nature. It not only provides a wealth of practical information for anyone working with radar in general (much of the information has application beyond weather radars). It also provides a good introduction to how such radars work at a very practical level. Examples including actual measurements from several radar facilities are used to illustrate the material presented.

Our Other Contributions

This issue contains the first example of some additional new columns for the *Radio Science Bulletin*.

The first of these is the History Corner. Giuseppe Pelosi has graciously agreed to be the Associate Editor for this column. In this first column, he and Stefano Selleri present a fascinating look at the life and work of Ottaviano-Fabrizio Mossotti. Mossotti’s contributions played a key role in James Clerk Maxwell’s development of the displacement current. Mossotti is also known for the Clausius-Mossotti equation, which, among other applications, relates the dielectric properties of a heterogeneous medium to those of an equivalent effective homogeneous medium. I think you will find this historical article and its illustrations quite interesting.

At the 2015 URSI GASS in Beijing, one or more Early Career Representatives (ECRs) were elected for each

URSI Commission. Stefan Wijnholds became Chair of the ECR Committee, and he has now agreed to join the *Radio Science Bulletin* as Associate Editor for an Early Career Representative Column. He introduces the column and his vision for it in this issue. The column also presents an article by Phil Wilkinson and Paul Cannon, the past and current Presidents of URSI. This article provides an introduction to URSI, and describes its structure and how it works. Even those who have been involved in URSI for some time are likely to learn something from reading this article.

Georgios Trichopoulos is taking over the Book Review column. George is look for suggestions for books to review, and volunteers interested in reviewing books of interest to radio scientists. Kristian Schlegel had been doing this for a number of years, and his efforts are greatly appreciated.

Since this is the December issue, a list of the officers and committees of URSI is included. Also included is contact information for all the people who give their time in these positions to make URSI work.

AP-RASC 2016

One of URSI's three "flagship" conferences, the Asia-Pacific Radio Science Conference (AP-RASC 2016), will be held August 21-25, 2016, at the Grand Hilton Seoul Hotel, Korea. This is going to be an exciting conference, with all 10 URSI Commissions participating. There is a Student Paper Competition, and Young Scientist Awards will be given. The call for papers appears in this issue. The paper-submission deadline is **March 15, 2016**. You should plan on making your submissions now!

Happy New Year!

We're into the second month of the Georgian calendar, and the lunar new year has just started. Whichever calendar you are looking at, I hope your new year is happy, healthy, safe, and prosperous – and that one of your resolutions is to share what you're doing in radio science in the pages of the *Radio Science Bulletin*!





The URSI Asia-Pacific Radio Science Conference (URSI AP-RASC) is a triennial conference for the exchange of information on the research and development in the field of radio science. It is one of the URSI Flagship Conferences with URSI GASS and URSI AT-RASC. The objective of the URSI AP-RASC is to review current research trends, present new discoveries, and make plans for future research and special projects in all areas of radio science, especially where international cooperation is desirable.

The 2016 URSI Asia-Pacific Radio Science Conference (URSI AP-RASC 2016) will be held at Grand Hilton Seoul Hotel, Seoul, Korea on August 21-25, 2016. We will have an open scientific program, composed of submitted papers within the domains covered by all the 10 Commissions of URSI.

Topical Areas

- Commission A: Electromagnetic Metrology, Electromagnetic Measurements and Standards
- Commission B: Fields and Waves
- Commission C: Radio-communication Systems and Signal Processing
- Commission D: Electronics and Photonics
- Commission E: Electromagnetic Noise and Interference
- Commission F: Wave Propagation and Remote Sensing
- Commission G: Ionospheric Radio and Propagation
- Commission H: Waves in Plasmas
- Commission J: Radio Astronomy
- Commission K: Electromagnetics in Biology and Medicine

Young Scientist Programs

The following two programs are planned for young scientists:

- Student Paper Competition (SPC)
- Young Scientist Award (YSA)

Paper Submission Deadline: **March 15, 2016**

All authors are requested to submit their papers written in English that are 2~4 pages in length. Please prepare your paper in PDF format for the submission. The detailed information on paper submission is now posted at the URSI AP-RASC 2016 website. (http://aprasc2016.org/Paper_Submission.php).

Special Issues

The following two special issues are scheduled for publication:

- URSI AP-RASC 2016 Special Issue (to be published in *Radio Science*)
- URSI AP-RASC 2016 SPC Special Issue (to be published in *Radio Science Bulletin*)

Important Dates

- **Paper Submission**
March 15, 2016
- **YSA/SPC Paper Submission**
March 31, 2016
- **Acceptance Notification**
April 30, 2016
- **Author Registration**
June 15, 2016
- **Early Registration**
July 15, 2016

Organized by



Co-organized by



Technically Co-sponsored by



Introduction to Special Section on Disaster Management

Tullio Joseph Tanzi

Institute Mines Telecom
Telecom ParisTech, LTCI UMR 5141 CNRS, France
E-mail: tullio.tanzi@telecom-paristech.fr

1. Disaster Management and URSI

Natural and man-made disasters cause indescribable losses in the areas concerned, both in terms of material wealth and human lives. Once the first emotions following a disaster are over and the topic is disappearing from the headlines, it is the turn of the scientists to analyze the disaster, its causes, and the way it has been managed.

Disaster management requires actions, ranging from anticipating possible consequences to responding and mitigating the effects of a real disaster. Risks inherent to all phases of a disaster are a challenge to our capacity to react quickly and efficiently. The risks may range from the safety of an individual to the economic situation of a region. Irrespective of the precise nature of the risk, it goes without saying that correctly applied knowledge reduces disaster-related risks.

To prevent certain of the worst aspects of disasters, science provides a broad scope of solutions. These include warnings of impending weather or other events (cyclones, tornadoes, floods, fires, droughts, tsunamis, and pestilence), or mitigation of their worst consequences. This is a continuing subject, raising the interest if not the participation of all scientists.

Radio science pervades society. It is an integral part of disaster management, including the mitigation of the effects of disasters. While the latter is often taken for granted, it is a significant part of all actions taken following disasters. For instance, the role of communications during and after a disastrous event is pivotal in assessing damage and providing relief. Each URSI Commission is a reservoir of specialized knowledge, able to contribute to finding new operational and technical approaches to public protection and disaster relief. With these objectives in mind, an Inter-Commission Working Group on Natural and Human Induced Hazards and Disasters was set up at the 2008 URSI GASS.

The impact of cooperation can be further increased when applied in conjunction with the other Scientific Unions of the International Council for Science (ICSU). In fact, this can open an even wider space of new applications for radio science. The International Society for Photogrammetry and Remote Sensing (ISPRS) and URSI have been working together to this end. This activity was initiated in 2009 by Prof. Francois Lefeuvre, when he was President of URSI, and Prof. Orhan Altan, the President of ISPRS. Joint meetings took place in Antalya (2010), in Istanbul (2011), and more recently, in Melbourne (2012). The joint approach will allow more complex problems to be recognized and addressed. URSI and ISPRS are two leading global scientific unions, providing complementary support and leadership to their respective communities. URSI is responsible, on an international basis, for stimulating and coordinating studies, research, applications, scientific exchange, and communication in the field of radio science. URSI encompasses the knowledge and study of all aspects of electromagnetic fields and waves. ISPRS covers complementary disciplines that are of particular interest for disaster management.

2. Disaster Management Special Section Papers

In the context of this issue, the following articles present various aspects covered by the reply URSI can bring to these problems.

2.1 Some Thoughts on Disaster Management

The first paper offers some thoughts on the field, and on the way to reach these objectives. Beyond science and technology, light is focused on aspects falling within the social sciences, such as ethics, legal, and social considerations.

2.2 DEMETER: Results Related to Seismic Activity

In the second paper, Michel Parrot and Mei Li offer us a detailed description of the DEMETER project and its results.

Do seismic and volcanic activity on the ground affect the electromagnetic environment of the Earth's atmosphere? Satellites have recorded some strange coincidences. The aim of DEMETER (Detection of Electro-Magnetic Emissions Transmitted from Earthquake Regions) was to obtain more-conclusive proof and explanations. Even though DEMETER did detect seismic activity affecting the ionosphere before certain tremors, the disturbances were so weak that they could only be statistically highlighted. Scientists therefore still cannot say if such disturbances of the electric field will appear before a specific tremor, and more broadly, whether we might one day be able to forecast earthquakes.

An original feature of DEMETER was its ability to measure transient very-low-frequency (VLF) electromagnetic phenomena. This provided new insights into the lower region of the ionosphere that had hitherto been studied very little, as it is too high for balloons to reach, and too low for satellites. Thanks to DEMETER's particle detector, research scientists have also been able to study the compression of the Earth's magnetic field during very strong magnetic storms, triggered by variations in the Sun's activity.

Launched in 2004, and operated by the French Space Agency, CNES, the DEMETER satellite observed electric and magnetic signals in the Earth's ionosphere for more than six years. The data it collected yielded more than 300 scientific articles.

2.3 Topology Control of Autonomous Aerial Drone Networks

In the third article, Daniel Camara discusses the use of a fleet of fully automated aerial drones for relief efforts. In particular, he focuses on the use cases of such a fleet, and the minimum requirements so that the drones can be effectively useful over disaster scenarios. After that, the paper presents a proposal for an autonomous topology management algorithm that is capable of maintaining a mission-based network topology. The algorithm is simple, yet capable of adapting to different requirements, and of enforcing a stable topology, even if all the nodes behave selfishly.

2.4 Designing Autonomous Crawling Equipment to Detect Personal Connected Devices and Support Rescue Operations: Technical and Societal Concerns

The last paper concerns the gathering and processing of reliable information, which is a major aspect of disaster management. Two new trends seem to currently be emerging. On the one hand, personal digital devices, such as smartphones, tablets, and smart watches are getting more and more popular. On the other hand, the range of applications for autonomous civilian drones and robots is becoming wider than before.

One can therefore make use of the latter to quickly detect the former when a crisis occurs, given the hypothesis that connected devices are nowadays mainly attached to a person rather than a place, as in the past. This paper thus aims at studying the technological and ethical, legal, and social questions that such a methodology raises. The paper proposes to frame our forthcoming research into an "ethics-by-design" approach, which will be supported by anticipating effective operational uses (an information-technologies appropriation approach).

Some Thoughts on Disaster Management

Tullio Joseph Tanzi

Institute Mines Telecom
Telecom ParisTech, LTCI UMR 5141 CNRS, France
E-mail: tullio.tanzi@telecom-paristech.fr

Abstract

A new generation of approaches has appeared in the field of disaster management. These serve to improve the awareness of the situation, and to lead the necessary assessment to ensure the collection of quality data, especially under difficult circumstances such as natural disasters. These approaches rely massively on automated gathering of qualified information. To reach this objective, two challenges must be addressed. The first challenge consists of achieving sufficient autonomy, both in terms of navigation and interpretation of the data, which will be turned into technical and scientific advances.

The second challenge concerns the reliability of systems (for example, unmanned aerial vehicles, or UAVs) being implemented from the point of view of the danger they may pose to the environment in which they operate. The design and development of new embedded architectures enable UAVs to be more autonomous, while mitigating the harm they can potentially cause. In this context, modeling, simulation, and various techniques of formal verification are used in order to validate the critical aspects of a platform, to increase its reliability and resilience. However, it is also necessary to take care of non-technical issues. Another consequence of the development of these new approaches is thus their impact on the preservation of privacy, and more generally, legal and administrative concerns. Taking into account aspects that are not normally our scientific and technological areas, such as, for example, the respect for the rights of the victim (privacy), must therefore be carried out jointly with the work of security (safety).

1. Introduction

Disasters, natural or manmade, inflict dreadful losses on the regions that experience them, both in terms of material wealth and human lives. In extreme cases, survivors may feel death is preferable, especially months

after the disaster, when recovery appears to have stalled. While media involve everybody in these events, the scale of the publicized devastation can be mind-numbing to the point of acting as an anesthetic, and time can erode the remaining compassion of the moment. Disasters demand action, from anticipating their potential to responding and mitigating their effects. Risks associated with all phases of a disaster are a measure of our ability to cope with them in a dynamic and highly stressful environment. These risks may refer to anything from the safety of an individual to the economic well-being of a region. Regardless of the exact nature of the threat, we believe that knowledge, correctly applied, will reduce the risks associated with a disaster.

Science has achieved much in alleviating some of the worst aspects of disasters, from providing warnings of impending weather events (cyclones, tornadoes, floods, fires, droughts, tsunamis, and pestilence) to mitigating the worst effects of the initial impact. This is an ongoing undertaking that engages the interest, if not the participation, of all scientists. Radio science pervades society, and plays a major role in disaster management and mitigation. This role is often taken for granted, even though it plays a significant role in the response to disasters. For instance, the role of communications during and after a disastrous event is pivotal for assessing damage and providing relief. Each URSI Commission is a reservoir of knowledge and contributions from experts. The assistance from all URSI Commissions can contribute to new operational and efficient approaches to manage the various events, that arise in our everyday life. With these objectives in mind, at the 2008 URSI GASS, an Inter-Commission Working Group on Natural and Human Induced Hazards and Disasters was created.

The effectiveness is even greater when radio science is applied in conjunction with other disciplines, represented by the other Scientific Unions of the International Council for Science (ICSU). In fact, this can open an even wider range of new applications for radio science. To this end, the International Society for Photogrammetry and Remote

Sensing (ISPRS) and URSI have been working together. This activity was initiated by Prof Francois Lefevre when he was President of URSI, and Prof Orhan Altan, the President of ISPRS. Joint meetings took place in Antalya, Istanbul, and more recently, in Melbourne. The joint approach will enable more complex problems to be recognized and addressed. URSI and ISPRS are two leading global scientific societies, providing complementary support and leadership to their respective communities. URSI is responsible for stimulating and coordinating, on an international basis, studies, research, applications, scientific exchange, and communication in the fields of radio science. It encompasses the knowledge and study of all aspects of electromagnetic fields and waves. ISPRS covers complementary disciplines of interest for a large scientific community.

In 2009, URSI and ISPRS agreed to organize common workshops on disaster management. Joint sessions were organized in Antalya (2010, GI4DM), Istanbul (2011, URSI GASS), Melbourne (2012, ISPRS GA), with contributions to the “VALID” document (the Value of Geo-Information for Disaster and Risk Management, 2013), edited by Prof. Orhan Altan.

As a continuation of the program, an URSI-ISPRS session will be organized during the XXIII ISPRS Congress 2016 in Prague. This will again focus on disaster and risk management. At the end of a session, the creation of a joint working group will be discussed to support longer-term coordination between ISPRS and URSI.

2. Disaster Management

Disaster management relies heavily on remote sensing and the underlying radio science that supports the remote-sensing and communication systems. Many of the challenges are interdisciplinary, and require sophisticated solutions. In this context, a good approach aims at highlighting and exploring the radio science and remote-sensing challenges that must be overcome to support humanitarian relief.

These include a wide variety of sensor systems, including ground-penetrating radars to look for buried people and objects, and the opportunistic detection of electromagnetic emissions from communications devices including cell phones and personal digital assistants (PDAs), which can help to locate lost persons. In both of these cases, the radio scientist is involved in the antenna design, the propagation of wideband signals through dispersive ground media, and also in the signal processing. The remote-sensing community then requires sophisticated search and recognition strategies to quickly identify targets.

All of the fields represented in our URSI Commissions and in the Technical Commission of the ISPRS are useful and necessary to develop an appropriate response to disasters. Indeed, when a natural disaster occurs in a populated zone, a fast and effective organization of disaster management

is required to assist the affected population, reduce the number of victims, and limit the economic impact [1]. At all phases of disaster management (pre-disaster, response, and post-disaster), one of the first actions to be taken is to set up a disaster-coordination authority. The detection and the monitoring of the impact of natural disasters on the terrain are mainly performed by spaceborne and airborne sensors, relying on radio and optical instruments [2, 3]. Contrary to optical observations, which may suffer from many constraints such as time of the day or weather (i.e., no observation at night or in the presence of cloud cover), radio observations are available 24/7, and relatively insensitive to atmospheric conditions. Radio observations are therefore particularly useful during the “response phase” of the disaster-management cycle, when information must be delivered as quickly as possible to the disaster coordination authority [4-6].

2.1 New Technological Trends for Disaster Management

UAVs may bring significant improvements with respect to these issues. Depending on the requirements of their potential mission, UAVs can be easily equipped with different kinds of sensors, including optical sensors. Of course, their altitude permits a higher quality of images and observation under the clouds. Finally, search and rescue teams may carry UAVs and deploy them following the needs of the site. For example, flying drones can be used to explore flooded areas, in order to find a practical path to victims. In this respect, UAVs extend the exploration range of rescue teams and, at the same time, improve their own safety in areas that may be dangerous. A good example is the senseFly UAV [7]. During the aftermath of the 2010 Haiti earthquake, this automatically mapped the region, enabling the authorities to quickly draw maps of devastated areas. These maps helped the rescue teams, and improved the lives of victims in the aftermath of the earthquake.

As explained in [8], new approaches and the use of new technologies are required for more-efficient risk management before, during, and after a potential crisis. Every specific action at each step of the crisis must be taken into account. For that purpose, new dedicated tools and methodologies are required to enhance the handling of crisis situations.

Use cases where drones have already been useful in humanitarian context are numerous. The cases described hereafter are just a small subset of these, for illustration purposes.

Danoffice IT has a commercial drone solution for disaster response [9]. It was used in real operation sites such as typhoon Yolanda in Tacloban, Philippines, where it helped in the identification of the operation site, and in the identification of feasible roads. During the same disaster, the CorePhil DSI team [10] used a fixed-wing drone, eBee,

to capture aerial imagery of downtown Tacloban. These images were further analyzed through crowd-sourcing, and helped in the generation of the most-detailed and up-to-date maps of the region. These maps were afterwards used by different humanitarian organizations, and even by the Filipino government.

The control of fleets of drones is also not a new theme. In fact, it is a well-studied subject in the military context. Of course, the purpose here is different, and the same goes for the flight control. However, even in military operations, the proposed fleet-control mechanisms basically intend to help humans control the drones, rather than providing a fully autonomous fleet. For example, Cummings et al. [11] proposed an automation architecture to help humans with the supervision of a fleet of drones. However, the drones were not completely autonomous: it was still up to the human operator to decide their mission. The same comments could apply for other work in the field, e.g., the work of Arslan and Inalhan [12], where the whole effort relied on helping one operator control multiple drones.

In a disaster scenario, drones can perform a number of different tasks to help with the relief effort. Tasks may vary from providing means of communication to the creation of high-resolution maps of the area, and the autonomous search for victims. Maintaining communications over disaster areas is challenging. One cannot just rely on the public communication networks: first, because these may be unavailable in remote areas, and second, because even if they are available, the network may be damaged or destroyed. Nevertheless, coordination of the relief efforts requires communication. Drones can work as temporary mobile access points for extending the coverage in affected areas. This service may be offered not only for the rescuers, but also for the general population, with the creation of small picocells. For example, after hurricane Katrina, in New Orleans, the public network was out of service. Verizon, the local provider, granted the right to use their frequencies to the first responders.

Another important task that can be autonomously performed is the creation of high-resolution maps of the affected area. Disasters may drastically change the affected region, which may completely void previous maps. Drones can fly over the region with three-dimensional cameras and, with the help of GPS and publicly available landscape maps of the region, automatically create up-to-date three-dimensional maps of the area. These maps can be used to understand the impact of the disaster over the region. For example, they can also be used to decide which roads need to be closed, which are the best paths to reach the most damaged areas, or even to help with the planning of the delivery of relief supplies.

Among active roles drones could play to help with search and rescue operations, we can highlight the infrared scan of the region, the use of ground-penetrating radars, or the systematic search for mobile phones by the detection of their specific radiation.

The next step consists in leading field experiments to acquire data to validate the approach. Indeed, so far we have not been able to anticipate certain behaviors. For instance, a typical mobile phone is supposed to look for a network while none is detected. This search requires the device to use full power, which drains a great amount of battery energy. That is why some manufacturers may decide for a time out, to spare this. We thus have to check to see if this type of policy is still compliant with the aim we try to reach. Another aspect concerns the adaptation of the approach considering the geographical area. Disasters can strike anywhere. The question is thus to determine how such a system can behave, for example, in developing countries with emerging network infrastructure, or compliance with the different local communication standards. Much remains to be done to reach an optimal operational use of drones.

From the technical point of view, sensors have to be improved to cope with the conditions available onboard drones. As far as instructions for use are concerned, international agreements are needed. (1) Several national administrations are opposing the identification of a dedicated harmonized frequency spectrum for public protection and disaster relief (PPDR), favoring a flexible solution that would enable national agencies to choose the most appropriate solution to meet national needs (see ITU-R Resolution 646 (Rev.WRC-15) and Resolution 647 (Rev.WRC-15)). (2) Agreement from the International Civil Aviation Organization (ICAO) is indispensable for using drones in any non-segregated space (see ITU-R Resolution COM4/5 (WRC-15)).

2.2 Ethical, Legal and Social Considerations

These extended capabilities introduce a new perception, which generates vulnerabilities that are essential to evaluate and assume. Even a catastrophic event such as a major crisis can be absorbed, a question remains: can victims' rights be bypassed to reach the goal of saving their life? Beyond the classical privacy concerns (pictures, video, etc.), there is also a technological aspect [13]. For example, through a hack can we take control of the mobile phone of a victim buried under rubble without his or her consent, even if it is to establish contact between the rescuers and the victim? Can we use the mobile device's embedded sensors (video, sound, etc.) to acquire information that will be used to determine how to reach the person [14]?

In "ELSI in Crisis, Do IT More Carefully," C. Rizza [15] demonstrated how research around the ethical, legal, and social (ELS) aspects of information technology (IT) for crisis management and response not only highlights challenges but reveals opportunities. She recognized that [15]

Emergency situations call for exceptions, including exceptions to fundamental and constitutional rights and suspension of normal moral rules and values, often

fuelled (but not always warranted) by fear of public moral disorder. Such exceptions can erode important civil liberties, and “the wrong kind” of IT innovation in crisis management can amplify a more pervasive “securitization” of society.

It is proposed to integrate information technology “more closely” into crisis response and management, with an explicit engagement with ethical, legal, and social considerations, in order to provide useful insights for a more informed and proactive approach to innovation.

The state of the art stresses three main concerns: data protection and privacy concerns; equality and social justice issues; and safety, liability, and responsibility issues. In our research, it is important to identify other ethical, legal, and social issues, such as the risk of the infringement of human dignity, and the potential impact upon civil liberties due to the pervasiveness of our systems (and algorithms).

We do not have answers to these questions, and part of them are statements of our colleagues in the humanities and social sciences. However, it is important for us to be aware of these issues, and to participate in their resolution. In 1524, Rabelais said “...*science sans conscience n'est que ruine de l'âme...*” [16] (...science without conscience is but the ruin of the soul...).

3. Conclusion

Among all the high-technology objects of our modern environment, drones have an impressively high potential to offer fast and efficient responses in rescue conditions, even if some difficulties must be tackled. New applications, such as intervention in hostile environments, require an effective autonomy of mini-drones concerning the energy (duration of the mission) and the command and control (decisional autonomy). Hardware and software issues have to be addressed: Which algorithmic architectures to adopt? Which embedded system configuration is the most suitable? Which kinds of interface are the most appropriate for victims standing in front of the drone? How can a drone help to appease people in critical conditions, or to provide useful information?

The design of a civilian UAV intended for intervention in post-disaster conditions is an important challenge. The gain in autonomy of drones, coupled with the use of unconventional sensors such as Lidar, IR cameras, etc., will strongly increase the response capabilities of the rescue teams on the ground, for example in people detection, rapid mapping, and damage estimation. To be effective, these customized sensor systems must perform their duties in an independent manner, and be able to communicate their data to the command center. The information will then be inserted into the decision-making cycle. It is also imperative that the manipulation of these systems does not

require any special skills. This condition is an indispensable requirement, which explains the rationale of our focus on autonomous flight and mission. Without that capacity, it would not be possible to correctly integrate these new tools within the flow of activities of rescue teams.

Under these circumstances, search and rescue can surely enough make use of drones for a large range of activities. However, if not autonomous and capable of self-organization, these elements can be more of a burden than helpful equipment in a catastrophe scenario. Rescuers must focus on the activity they have at hand: saving lives. It is not their job to spend their time handling drones and the tasks of drones. The proposed architecture intends to provide the organization required for a fleet of drones to autonomously, in a push-button way, scan the region, and provide useful information. Another intention for the proposed architecture is to use this fleet to provide communication over disaster areas, even for severely affected areas.

It is also important to notice that drones should be able to perform opportunistic communication, and to synchronize with nearby nodes. In a disaster scenario, store-carry-and-forward techniques may be the only way to convey important information among the computational elements. Drones can exchange information with each other about the route and the strategies they are taking. For example, if they are moving in the direction of the operations center, they can carry the messages of other drones until their final delivery at the destination. In the same way, message ferries have been designed [5].

Different kinds of drones may provide different services and, ideally, should play the roles they best fit. Even though we could exchange some of the tasks among the different drones, this would have an impact on the end results. For example, we could without a doubt use fixed-wing drones to create a mobile backbone. However, not only would the organization of the drones to provide constant full coverage be more complex, but the lifetime of the backbone would also suffer.

The use of these new tools – such as, for example UAVs – can induce a physical danger to victims and rescuers in case of malfunction. It is therefore essential to ensure that their use generates no risks to their environment. Taking into account aspects that are not, in principle, in our scientific and technological scope, such as respect for the rights of the victim (privacy), must be jointly conducted with the work of security (safety). It is important to ensure that information acquired in the crisis cannot be diverted for other purposes.

4. References

1. D. Guha-Sapir D, Ph. Hoyois, and R. Below, “Annual Disaster Statistical Review 2012: The Number and Trends,” Brussels, CRED, 2013.

2. T. J. Tanzi and F. Lefevre, "Radio Sciences and Disaster Management," *C. R. Physique*, **11**, 2010, pp. 114-224.
3. M. Chandra, "Overview of Modern Multi-Parameter Methods of Radar Remote Sensing in Context of Disaster Management," XXXI General Assembly and Scientific Symposium of the International Union of Radio Science (URSI GASS 2014), August 17-23, 2014, Beijing, China.
4. P. Wilkinson and D. Cole, "The Role of the Radio Sciences in the Disaster Management," *Radio Science Bulletin*, 335, December 2010, pp. 45-51.
5. F. Lefevre and T. Tanzi, "International Union of Radio Science, International Council for Science (ICSU), Joint Board of Geospatial Information Societies (jBGIS)," United Nations Office for Outer Space Affairs (OOSA), 2013.
6. T. Tanzi and F. Lefevre, "The Contribution of Radio Sciences to Disaster Management," International Symposium on Geo-Information for Disaster Management (Gi4DM 2011), Antalya, Turkey, 2011.
7. E. Ackerman, "Drone Adventures Uses UAVs to Help Make the World a Better Place," *IEEE Spectrum*, May 2013.
8. T. Tanzi and P. Perrot, "Télécoms pour l'Ingénierie du Risque," in Hermès (ed.) *Collection Technique et Scientifique des Télécoms*, Paris, France, 2009 (in French).
9. Jesper Pedersen, "Use of UAVs in the NGO World," CRS Conference – ICT4Development, Nairobi, Kenya, March 25-28, 2014.
10. Patrick Meier, "Humanitarians in the Sky: Using UAVs for Disaster Response," June 25, 2014, available at <http://irevolution.net/2014/06/25/>, last viewed June 30, 2014.
11. M. L. Cummings, S. Bruni, S. Mercier, and P. J. Mitchell, "Automation Architecture for Single Operator, Multiple UAV Command and Control," *The International C2 Journal*, **1**, 2, 2007, pp. 1-24.
12. Oktay Arslan and Gokhan Inalhan, "Design of a Decision Support Architecture for Human Operators in UAV Fleet C2 Applications," 14th International Command and Control Research and Technology Symposium (ICCRTS), Washington, DC, June 2009.
13. T. J. Tanzi, O. Sebastien, and F. Harivelo, "Towards a Collaborative Approach for Disaster Management Using Radio Science Technologies," *Radio Science Bulletin*, 348, March 2014, pp. 25ff.
14. O. Sebastien, F. Harivelo, and D. Sebastien, "Using General Public Connected Devices for Disasters Victims' Location," URSI XXXIth General Assembly and Scientific Symposium, 2014, pp. 1-4.
15. M. Büscher, M. Lieg, C. Rizza, and H. Watson, "Special Issue on How to do IT More Carefully: Ethical, Legal, and Social Issues (ELSI) in IT Supported Crisis Response and Management International," *Journal of Information Systems for Crisis Response and Management*, **6**, 4, October-December 2014, pp. iv-xxiii.
16. Pantagruel, "Comment Pantagruel, estant à Paris, receult lettres de son père Gargantua, et la copie d'icelles," in Gallimard (ed.), *Rabelais*, 1964, Chapter VIII, p. 137.

DEMETER Results Related to Seismic Activity

Michel Parrot¹ and Mei Li²

¹LPC2E/CNRS
3 Avenue de la Recherche Scientifique
45071 Orleans Cedex 2, France
E-mail: mparrot@cns-orleans.fr

²China Earthquake Network Center
China Earthquake Administration
No. 5, Sanlihe Nanhengjie, Xicheng District, Beijing, 100045
E-mail: limeixuxl@seis.ac.cn

Abstract

For many years, possible electromagnetic effects prior to earthquakes have been searched for in ground-based and satellite data. These events are interesting because they can be considered as short-term precursors (between a few hours and a few days). During more than six years, the DEMETER micro-satellite was dedicated to checking ionospheric perturbations in relation to seismic activity. However, seismic activity has only a small effect on the ionosphere, which is under the constraints of many different phenomena (solar activity, geomagnetic activity, meteorological events, and anthropogenic effects). To reveal a seismic effect, statistical analyses were then performed with the ionospheric parameters recorded by DEMETER. This paper mainly reports the conclusions of these analyses, which indicated that there were perturbations in the ionosphere prior to earthquakes. However, at the end, it was shown with the example of the 2010 Chile earthquake that it was impossible to make a full earthquake prediction.

1. Introduction

Since ancient times, it has been known that seismic activity is able to trigger electromagnetic disturbances in the atmosphere [1]. However, it was only in the 1980s that researchers started to widely study these phenomena, with various ground-based experiments. The main interest is that sometimes these events can be considered as short-term precursors. These events have been also detected in the ionosphere by satellite (see, for example, [2]). In 2000, CNES (the French National Space Agency) decided to launch a dedicated micro-satellite named DEMETER (Detection of Electro-Magnetic Emissions Transmitted from Earthquake

Regions). The main scientific objective of DEMETER was not to predict earthquakes, but to study these disturbances in the ionosphere due to the seismo-electromagnetic effects prior to earthquakes.

This paper summarizes the results obtained by DEMETER. The mechanisms that could be responsible for these effects in the ionosphere will not be discussed here: one can see, for example, the recent studies in [3-10]. Section 2 contains a short description of the satellite and its payload. Results of statistical analysis are shown in Section 3. A case study is processed in Section 4, to try to answer the question, “Is it possible to predict an earthquake?” Section 5 presents conclusions.

2. The DEMETER Satellite

DEMETER was a micro-satellite (130 kg), with a low-altitude (710 km) and nearly polar orbit [11]. The launch was in June 2004, and the mission ended in December 2010. The orbit was nearly sun-synchronous (10:30 – 22:30 LT). In order to achieve this objective, the payload of the micro-satellite allowed measuring waves in different frequency ranges, and also some important plasma parameters (ion composition, electron density and temperature, energetic particles). The scientific payload was composed of several sensors:

- Three electric and three magnetic sensors (six components of the electromagnetic field to investigate from dc up to 3.5 MHz)
- A Langmuir probe
- An ion spectrometer
- An energetic particle analyzer.

There were two modes of operation: (i) a survey mode, to record low-bit-rate data; and (ii) a burst mode, to record high-bit-rate data, above seismic regions. The difference between the burst and the survey modes mainly concerned the wave experiment. All details concerning the onboard experiments can be found in [12-16].

DEMETER recorded data all around the Earth, but with some restrictions. Data were not recorded in the auroral zones (invariant latitude $> 65^\circ$), because the seismic activity is low (except in Alaska), and the large level of natural noise could prevent observations of signals due to this seismic activity. The data were stored in the large onboard memory, which was downloaded when the satellite was above Toulouse (on average, two times per day). The data were then sent to the DEMETER mission center in Orléans for processing [17]. All data files were organized by half-orbits (day side, night side).

3. The results

During the lifetime of DEMETER, many ionospheric perturbations were observed in relationship to earthquakes. Many examples can be found in [18-46]. As the ionosphere also has variations not related to seismic activity, it was important to show that the observations that we attributed to earthquakes were very uncommon. This was done in [35, 41], where the ionospheric behaviors a long time before the occurrence of powerful earthquakes were studied at the same location. In the following, we will consider more complete statistics performed with the complete set of DEMETER data.

3.1 Statistics with the VLF Data

A statistical study of the variations of the electric field up to 10 kHz was performed in [47, 48]. The intensity of the signal received when the satellite passed close to the epicenter of an earthquake some days before and after was then compared with its mean intensity at the same place and under the same conditions. More than 2.5 years of satellite data have been analyzed, and about 2000 earthquakes with magnitudes larger than or equal to 4.8 were taken into account.

As a first step, geographic maps of the electric-field intensity were built as a function of various parameters (local time, magnetic activity, frequency, and season) that are known to have an influence on electromagnetic waves. During the period of analysis, a histogram of the wave electric-field intensity and a cumulative distribution function in the range between 0 and 1 were built for each cell of these maps.

In a second step, the data related to earthquakes (satellite orbits close to epicenters in space and in time) were considered. The values of the recorded data along the orbits

were compared with the histograms in the corresponding geographic cells to determine at which values of the cumulative distribution function they corresponded. A superposed epoch method (all earthquake occurrences were adjusted to a zero time) was then used to display these values of the cumulative distribution function considering the time (before and after the earthquakes) and the distance between the projection of the satellite orbit and the epicenters.

This study showed that in the night sector (22:30 LT), there was a statistically significant decrease, by 4 dB to 6 dB, of the measured wave intensity shortly (~ 4 hours) before earthquakes with their epicenter at a depth less than or equal to 40 km. Aftershocks were removed from the database, in order not to mix pre- and post-seismic effects. The results were presented as a function of the frequency under the form of relative intensity normalized by the standard deviation. They showed a decrease of the wave intensity measured by DEMETER (more intense when the magnitude was larger) in a frequency range between 1 kHz and 2 kHz. It is important to note that the frequency band where the decrease was observed could be related to the cutoff frequency, f_c , of the first TM mode in the Earth-ionosphere waveguide during the nighttime. It was shown in [49] that the frequency is given by $f_c = nc/2h$, where n is the mode number, c is the velocity of light, and h is the height of the Earth-ionosphere waveguide. For $n = 1$ and $h = 90$ km, one obtains $f_c = 1666$ Hz. If the intensity of the electric field decreases, this means that the cutoff frequency is increasing, and it then means that the height of the ionosphere is statistically lower above the epicenters. This study therefore statistically showed that there was an excess of ionization at the bottom of the ionosphere above epicenters.

The work in [47] was extended in [50, 51] using the complete DEMETER data set at the end of the mission (9000 earthquakes). With more than six years of data, these results exactly confirmed the previous results.

3.2 Statistics with the Density of the Ionosphere

Several statistical analyses have been performed with the complete sets of electron and ion density data. First, the density close to the epicenters of earthquakes between one and 30 days before the quake, and the density recorded at the same location between 31 and 75 days before the quake, were compared in [52, 53]. They normalized this ratio by the variance, and they averaged this quantity for all earthquakes as a function of the distance from the epicenters. Statistically, they have shown that there was an increase of the density close to the epicenters during nighttime. This increase did not occur if we replaced the locations of the earthquakes by locations which were randomly chosen. This increase was also more important if the magnitude of the earthquakes was larger. It disappeared if the depth of the earthquakes was larger than 60 km.

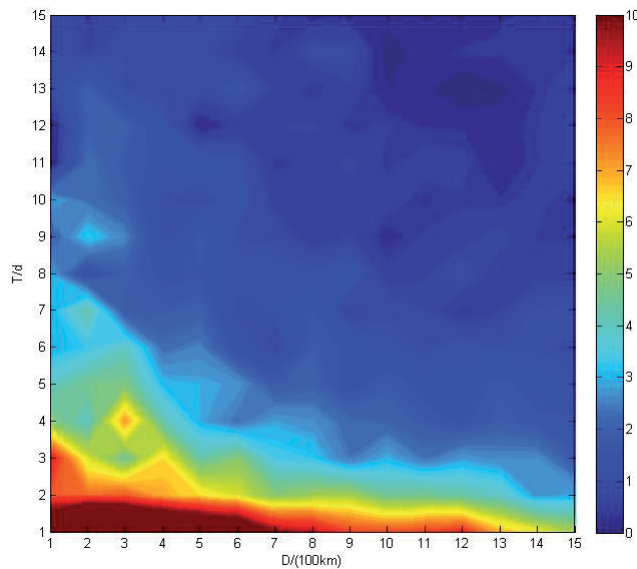

Figure 1. A two-dimensional histogram of the ionospheric anomalies as function of the days, T , before the earthquakes and the distances, D , between the epicenter and the projection of the DEMETER orbit on the Earth's surface. The color scale on the right is related to the number of events in each bin.

In relation to the variations of the density and the temperature, a study of the lower-hybrid resonance (LHR) frequency was done in [54], with three years of DEMETER data. They globally plotted the maps of the lower-hybrid resonance frequency, and the spectral intensity maps of VLF ground-based transmitters that had frequencies close to the lower-hybrid resonance frequencies. On the one hand, they showed that the spectral intensities depended on the relationship between the transmitter frequency and the lower-hybrid resonance frequency. On the other hand, they showed a variation of the lower-hybrid resonance frequency before earthquakes compared to the resonance frequency's regular behavior, over several seismic regions. They concluded that the variations of the VLF transmitter signal intensity could be used as a possible earthquake precursor (see, for example, [18, 20-23, 27, 28]).

In [55, 56] a statistical analysis was performed in two steps. In the first step, the authors automatically searched for ionospheric density peaks in the complete DEMETER data set (6.5 years). They then eliminated perturbations during large geomagnetic activity, and those not above seismic areas. The outputs were the amplitude, time, and location of the perturbations. In a second step, the authors used a list of earthquakes, and automatically checked to see if a given perturbation could be attributed to a given earthquake. The parameters were the earthquake's magnitude and depth; the maximum distance, D , between the earthquake's epicenter and the perturbation location; and the maximum time, T , between the earthquake and the perturbation occurrence. The outputs were the number of good detections (one perturbation corresponded to one earthquake), the number of false alarms (one perturbation but no earthquake), and the number of bad detections (no perturbation but one earthquake).

For $D = 0$ to 1500 km and $T = 0$ to 15 days, it was shown that r , the number of detected earthquakes over the

number of all earthquakes, was equal to 44.7%, 51.2%, and 72.9%, for earthquakes with magnitudes $M = 4.8$ to 5, 5.1 to 6, and > 6 , respectively. The average number of perturbations for a detected earthquake was equal to 3.1, 3.5, and 5.1 for the same three magnitude ranges. The number of false alarms was 22.9%. This meant that the numbers of false alarms and wrong detections were high.

The results of [55, 56] were used to develop a further analysis, which is shown in Figure 1. Considering all earthquakes (18778 out of 21863) that were at a latitude less than 45° , the number of detected earthquakes was 6263, and the number of corresponding perturbations was 14240 (there were earthquakes with several perturbations on the same day, or on different days). Here, we only selected the nearest perturbation of each detected earthquake, regardless of the detected time, and we then got 6263 perturbations. For all these 6263 perturbations, we created a statistic according to the perturbation day (from Day to Day-15), and the distance, D , with a 100 km bin (from 100 km to 1500 km). This spatio-temporal histogram related to these detected earthquake perturbations is shown in Figure 1.

The good points (the variations that were expected) of the statistical analysis in [55, 56] and in Figure 1 are:

- The number of earthquakes that were detected increased with magnitude.
- The number of perturbations increased with the earthquake's magnitude.
- The number of perturbations was maximum just the day before the earthquake. It remained important until four to five days before, and then decreased (see Figure 1).
- The average amplitude of the perturbations increased with the earthquake's magnitude.

However, these results must be considered with caution, because a good detection did not mean that we were able to predict the earthquake. Uncertainty about the position was large. Uncertainties about the time and the magnitude were much larger. The false alarms were due to natural variations of the ionosphere. The number of wrong detections was also important, and can be explained by the fact that the satellite was above a seismic area only a few minutes per day, and that we did not expect continuous perturbations from a given earthquake. Possible perturbations could thus be missed. It would be feasible to reduce this number of wrong detections if several satellites were simultaneously used. At the moment, the ESA (European Space Agency) SWARM mission has three identical satellites in the ionosphere.

4. A “Real Time” Analysis Related to the 2010 Chile Earthquake

This Chile earthquake of moment magnitude 8.8 occurred on February 27, 2010, with an epicenter located at 35.85°S, 72.72°W. The related ionospheric anomalies were already studied in [41, 57-60]. Here, we just wanted to see if it was possible to predict this earthquake using the database of ionospheric anomalies described in Section 3.2 [55]. It must again be noticed that these anomalies were automatically detected. We checked these anomalies day by day, as if we were in real time, considering an area limited in latitude (−50°, −25°) and longitude (90°W, 55°W) along the fault, which follows the coast of Chile. We assumed we knew nothing except the past. Using the first

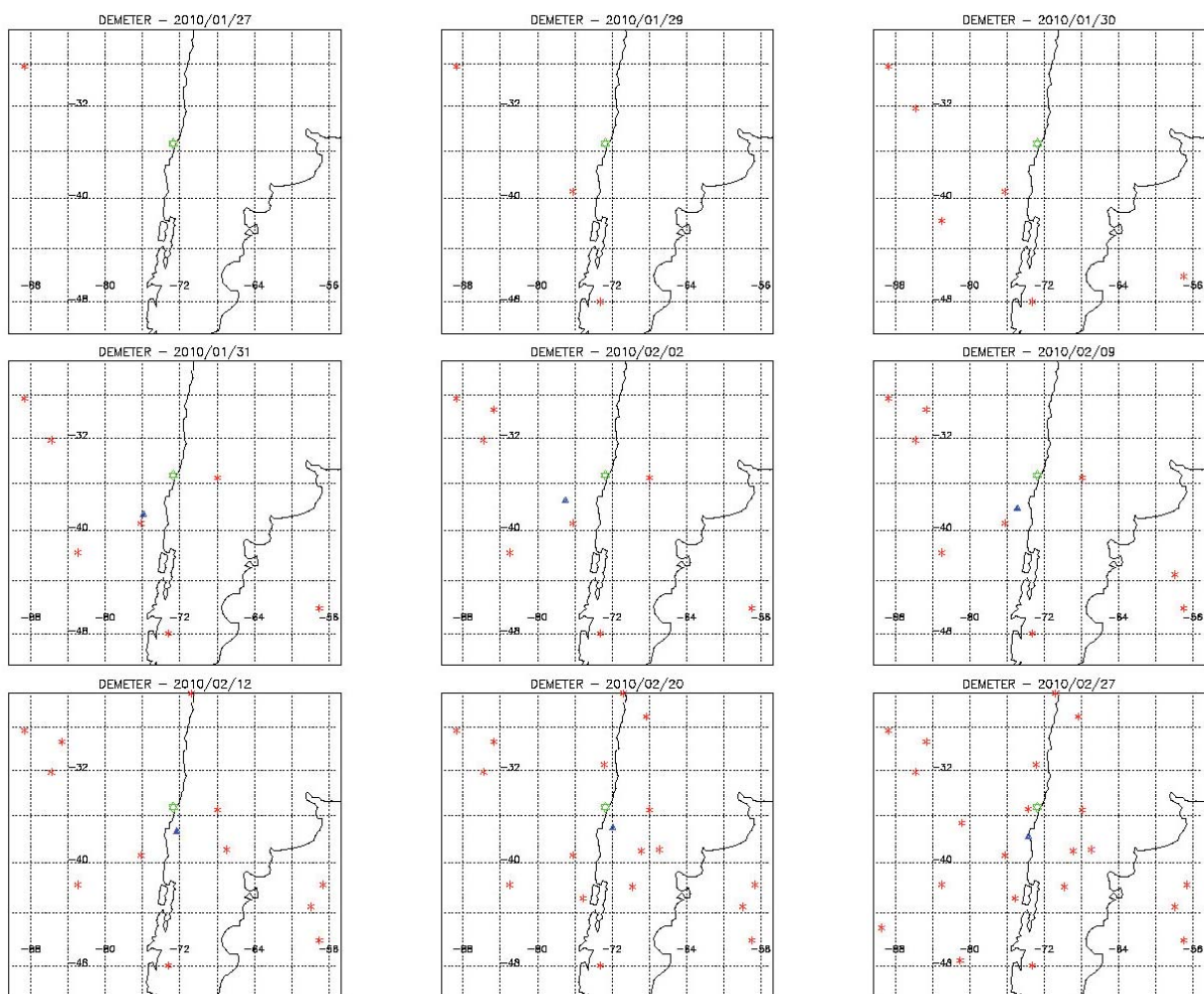

Figure 2. Maps of the Chile region, where the latitudes and the longitudes are indicated. The red crosses indicate the locations of the ionospheric perturbations recorded prior to the 2010 earthquake, which is indicated by the green star. From the left to right and from the top to bottom, each panel corresponds to the day written in the title. The last panel corresponds to the earthquake day. The blue triangle corresponds to the automatic determination of the epicenter obtained by the average of the anomaly positions (see the text for an explanation).

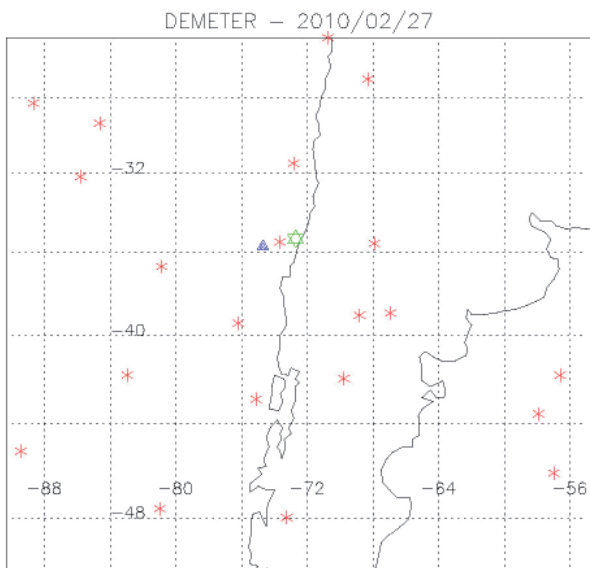

Figure 3. The same panel as the last panel in Figure 2, but wherein the automatic determination of the epicenter used the amplitude of the anomalies.

three months of the years 2007, 2008, and 2009, density variations were monitored in the vicinity of the epicenter at the same local time and seasonal conditions in [41]. Their Figure 5 indicated that an increase of the plasma density was very uncommon at this location and at this time. In our database, we selected relative anomalies larger than 20%.

The results of our process are shown in Figure 2. The days for each panel run from the left to the right and from the top to the bottom. We started to plot an anomaly on the map on January 27, 2010 (i.e., one month before the earthquake), and we then automatically plotted other anomalies for the other days. On January 31, 2010, there were several anomalies in the area, and we decided to average the positions of all anomalies in order to determine the position of a possible earthquake. This position is indicated by a blue triangle. The time was going on and we continued the automatic process. Each day, we recalculated the position of a possible earthquake. At the end, we arrived on February 27, 2010, the day of the earthquake, but it was impossible to know that it was the day of the earthquake. It was impossible to predict the time of the earthquake. We could just give a warning to say that anomalies were registered in the vicinity of a given location. Concerning the magnitude of this earthquake, we could just say that it must be a large magnitude, because anomalies started to appear tens of days before. A better determination of the epicenter would be found if we weighted the position of the anomalies with their amplitudes. This was done in Figure 3.

One must mention that when we visually selected the three half-orbits where the amplitude of the density perturbation reached a maximum, the locations of these maxima were aligned. The intersection of this line with

the known fault also gave a good approximation of the earthquake's epicenter location [41, Figure 4].

5. Conclusion

Using DEMETER data, we statistically showed that there are ionospheric perturbations prior to earthquakes. Density perturbations at the altitude of the satellite and at the bottom of the ionosphere were detected during nighttime. No amplitude perturbation of the electromagnetic waves was observed, but the wave anomalies concerned the propagation of these waves in the Earth-ionosphere waveguide. It was not possible to make earthquake predictions, because uncertainties about the occurrence time were too high.

At the moment, another dedicated ionospheric satellite, named CSES (China Seismo-Electromagnetic Satellite), is being developed in China (CIE) [61]. Its scientific payload will have more experiments than onboard DEMETER. The important point is that there are a lot of ground-based experiments in China, measuring many parameters linked to the seismic activity. It is expected that the comparison between the two data sets (ground and satellite) will lead to a better understanding of these seismo-electromagnetic effects.

A full earthquake prediction (location, time, magnitude) is unrealistic, but in the future, it will be possible to give an earthquake warning if many parameters (seismic, atmospheric, ionospheric) are simultaneously monitored. To our knowledge, this has been done only once in the past, on February 4, 1975, in Haicheng, China, prior to a M7.3 earthquake [62].

6. Acknowledgement

The DEMETER satellite was supported by the Centre National d'Etudes Spatiales. ML acknowledges funding from NSFC (National Natural Science Foundation of China) under grant agreement No. 41204057.

7. References

1. J. Milne, "Earthquakes in Connection with Electric and Magnetic Phenomena," *Transactions of the Seismological Society of Japan*, **15**, 1890, pp. 135-162.
2. M. B. Gokhberg, V. A. Pilipenko, and O. A. Pokhotelov, "Satellite Observation of the Electromagnetic Radiation above the Epicentral Region of an Incipient Earthquake," *Doklady Akademii Sciences USSR Earth Science Series*, **268**, 1, 1983, pp. 5-7 (English Translation).
3. F. Freund, A. Takeuchi, and B. Lau, "Electric Currents Streaming out of Stressed Igneous Rocks—A Step towards Understanding Pre-Earthquake Low Frequency EM Emissions," *Physics and Chemistry of the Earth*, **31**, 4-9, 2006, pp. 389-396.

4. S. A. Pulinet, "Physical Mechanism of the Vertical Electric Field Generation over Active Tectonic Faults," *Advances in Space Research*, **44**, 6, September 2009, pp. 767-773.
5. **R. G. Harrison, K. L. Aplin, and M. J. Rycroft**, "Atmospheric Electricity Coupling Between Earthquake Regions and the Ionosphere," *Journal of Atmospheric and Solar Terrestrial Physics*, **72**, April 2010, pp. 376-381.
6. S. Pulinet and D. Ouzounov, "Lithosphere – Atmosphere – Ionosphere Coupling (LAIC) Model – An Unified Concept for Earthquake Precursors Validation," *Journal of Asian Earth Sciences*, **41**, June 2011, pp. 371-382.
7. S. Pulinet, "Low-Latitude Atmosphere-Ionosphere Effects Initiated by Strong Earthquakes Preparation Process," *International Journal of Geophysics*, **2012**, Article ID 131842, 14 pp.
8. S. Pulinet and D. Davidenko, "Ionospheric Precursors of Earthquakes and Global Electric Circuit," *Advances in Space Research*, **53**, 5, March 2014, pp. 709-723.
9. R. P. Dahlgren, M. J. S. Johnston, V. C. Vanderbilt, and R. N. Nakaba, "Comparison of the Stress Stimulated Current of Dry and Fluid Saturated Gabbro Samples," *Bulletin of the Seismological Society of America*, **104**, 6, November 2014, pp. 2662-2672.
10. T. Xu, H. Zhang, Y. Hu, and J. Wu, "Electric Field Penetration into the Ionosphere in the Presence of Anomalous Radon Emanation," *Advances in Space Research*, **55**, 12, June 2015, pp. 2883-2888.
11. T. Cussac, M. A. Clair, P. Ultré-Guerard, F. Buisson, G. Lassalle-Balier, M. Ledu, C. Elisabelar, X. Passot, and N. Rey, "The DEMETER Microsatellite and Ground Segment," *Planetary and Space Science*, **54**, 5, April 2006, pp. 413-427.
12. J. J. Berthelier, M. Godefroy, F. Leblanc, E. Seran, D. Peschard, P. Gilbert, and J. Artru, "IAP, the Thermal Plasma Analyzer on DEMETER," *Planetary and Space Science*, **54**, 5, April 2006, pp. 487-501.
13. J. J. Berthelier, M. Godefroy, F. Leblanc, M. Malingre, M. Menvielle, D. Lagoutte, J. Y. Brochot, F. Colin, F. Elie, C. Legendre, P. Zamora, D. Benoist, Y. Chapuis, and J. Artru, "ICE, the Electric Field Experiment on DEMETER," *Planetary and Space Science*, **54**, 5, April 2006, pp. 456-471.
14. J. P. Lebreton, S. Stverak, P. Travnicek, M. Maksimovic, D. Klinge, S. Merikallio, D. Lagoutte, B. Poirier, Z. Kozacek, and M. Salaquarda, "The ISL Langmuir Probe Experiment and its Data Processing Onboard DEMETER: Scientific Objectives, Description and First Results," *Planetary and Space Science*, **54**, 5, April 2006, pp. 472-486.
15. M. Parrot, D. Benoist, J. J. Berthelier, J. Blecki, Y. Chapuis, F. Colin, F. Elie, P. Fergeau, D. Lagoutte, F. Lefeuvre, C. Legendre, M. Lévêque, J. L. Pinçon, B. Poirier, H. C. Seran, and P. Zamora, "The Magnetic Field Experiment IMSC and its Data Processing Onboard DEMETER: Scientific Objectives, Description and First Results," *Planetary and Space Science*, **54**, 5, April 2006, pp. 441-455.
16. J. A. Sauvaud, T. Moreau, R. Maggiolo, J. P. Treilhou, C. Jacquy, A. Cros, J. Coutelier, J. Rouzaud, E. Penou, and M. Gangloff, "High Energy Electron Detection Onboard DEMETER: The IDP Spectrometer, Description and First Results on the Inner Belt," *Planetary and Space Science*, **54**, 5, April 2006, pp. 502-511.
17. D. Lagoutte, J. Y. Brochot, D. de Carvalho, F. Elie, F. Harivelo, Y. Hobara, L. Madrias, M. Parrot, J. L. Pinçon, J. J. Berthelier, D. Peschard, E. Seran, M. Gangloff, J. A. Sauvaud, J. P. Lebreton, S. Stverak, P. Travnicek, J. Grygorczuk, J. Slominski, R. Wronowski, S. Barbier, P. Bernard, A. Gaboriaud, and J. M. Wallut, "The DEMETER Science Mission Centre," *Planetary and Space Science*, **54**, 5, April 2006, pp. 428-440.
18. O. Molchanov, A. Rozhnoi, M. Solovieva, O. Akentieva, J. J. Berthelier, M. Parrot, F. Lefeuvre, P. F. Biagi, L. Castellana, and M. Hayakawa, "Global Diagnostics of the Ionospheric Perturbations Related to the Seismic Activity Using the VLF Radio Signals Collected on the DEMETER Satellite," *Natural Hazards and Earth System Sciences*, **6**, August 2006, pp. 745-753.
19. M. Parrot, J. J. Berthelier, J. P. Lebreton, J. A. Sauvaud, O. Santolik, and J. Blecki, "Examples of Unusual Ionospheric Observations Made by the DEMETER Satellite Over Seismic Regions," *Physics and Chemistry of the Earth*, **31**, 4-9, 2006, pp. 486-495.
20. A. Rozhnoi, O. Molchanov, V. Solovieva, O. Gladyshev, O. Akentieva, J. J. Berthelier, M. Parrot, F. Lefeuvre, M. Hayakawa, L. Castellana, and P. F. Biagi, "Possible Seismo-Ionosphere Perturbations Revealed by VLF Signals Collected on Ground and on a Satellite," *Natural Hazards and Earth System Sciences*, **7**, October 2007, pp. 617-624.
21. A. Rozhnoi, M. Solovieva, O. Molchanov, O. Akentieva, J. J. Berthelier, M. Parrot, P. F. Biagi, and M. Hayakawa, "Statistical Correlation of Spectral Broadening in VLF Transmitter Signal and Low-Frequency Ionospheric Turbulence from Observation on DEMETER Satellite," *Natural Hazards and Earth System Sciences*, **8**, October 2008, pp. 1105-1111.
22. A. Rozhnoi, M. Solovieva, O. Molchanov, P. F. Biagi, M. Hayakawa, K. Schwingenschuh, M. Boudjada, and M. Parrot, "Variations of VLF/LF Signals Observed on the Ground and Satellite During a Seismic Activity in Japan Region in May-June 2008," *Natural Hazards and Earth System Sciences*, **10**, March 2010, pp. 529-534.
23. E. Slominska, J. Blecki, M. Parrot, and J. Slominski, "Satellite Study of VLF Ground-Based Transmitter Signals during Seismic Activity in Honshu Island," *Physics and Chemistry of the Earth, Parts A/B/C*, **34**, 6-7, 2008, pp. 464-473.
24. X. Ouyang, X. Zhang, X. Shen, J. Liu, J. Qian, J. Cai, and S. Zhao, "Ionospheric Ne Disturbances Before 2007 Puer, Yunnan, China, Earthquake," *Acta Seismologica Sinica*, **21**, 4, July 2008, pp. 425-437.
25. R. Zhu, D. Yang, F. Jing, J. Yang, and X. Ouyang, "Ionospheric Perturbations Before Pu'er Earthquake Observed on DEMETER," *Acta Seismologica Sinica*, **21**, 1, January 2008, pp. 77-81.

26. M. Y. Boudjada, K. Schwingenschuh, H. K. Biernat, J.J. Berthelier, J. Blecki, M. Parrot, M. Stachel, O. Aydogar, G. Stangl, and E. Weingrill, "Similar Behaviors of Natural ELF/VLF Ionospheric Emissions and Transmitter Signals over Seismic Adriatic Regions," *Natural Hazards and Earth System Sciences*, **8**, November 2008, pp. 1229-1236.
27. F. Muto, M. Yoshida, T. Horie, M. Hayakawa, M. Parrot, and O. A. Molchanov, "Detection of Ionospheric Perturbations Associated with Japanese Earthquakes on the Basis of Reception of LF Transmitter Signals on the Satellite DEMETER," *Natural Hazards and Earth System Sciences*, **8**, February 2008, pp. 135-141.
28. M. S. Solovieva, A. A. Rozhnoi, and O. A. Molchanov, "Variations in the Parameters of VLF Signals on the DEMETER Satellite During the Periods of Seismic Activity," *Geomagnetism and Aeronomy*, **49**, 4, August 2009, pp. 532-541.
29. Z. Zeng, B. Zhang, G. Fang, D. Wang, and H. Yin, "The Analysis of Ionospheric Variations before Wenchuan Earthquake with DEMETER Data," *Chinese Journal of Geophysics*, **52**, 1, January 2009, pp. 11-19.
30. X. Zhang, J. Qian, X. Ouyang, X. Shen, J. Cai, and S. Zhao, "Ionospheric Electromagnetic Perturbations Observed on DEMETER Satellite before Chile M7.9 Earthquake," *Earthquake Science*, **22**, 3, June 2009, pp. 251-255.
31. X. Zhang, J. Qian, X. Ouyang, J. Cai, J. Liu, X. Shen, S. Zhao, "Ionospheric Electro-Magnetic Disturbances Prior to Yutian 7.2 Earthquake in Xinjiang," *Chinese Journal of Space Sciences*, **29**, 2, 2009, pp. 213-221.
32. X. Zhang, X. Shen, J. Liu, X. Ouyang, J. Qian, and S. Zhao, "Analysis of Ionospheric Plasma Perturbations Before Wenchuan Earthquake," *Natural Hazards and Earth System Sciences*, **9**, July 2009, pp. 1259-1266.
33. X. Zhang, X. Shen, J. Liu, X. Ouyang, J. Qian, and S. Zhao, "Ionospheric Perturbations of Electron Density Before the Wenchuan Earthquake," *International Journal of Remote Sensing*, **31**, 13, July 2010, pp. 3559-3569.
34. X. Zhang, J. Liu, X. Shen, M. Parrot, J. Qian, X. Ouyang, S. Zhao, and J. Huang, "Ionospheric Perturbations Associated with the M8.6 Sumatra Earthquake on 28 March 2005," *Chinese Journal of Geophysics*, **53**, 3, May 2010, pp. 567-575.
35. M. Akhoondzadeh, M. Parrot, and M. R. Saradjian, "Investigation of VLF and HF Waves Showing Seismo-Ionospheric Anomalies Induced by the 29 September 2009 Samoa Earthquake (Mw = 8.1)," *Natural Hazards and Earth System Sciences*, **10**, May 2010, pp. 1061-1067.
36. J. Blecki, M. Parrot, and R. Wronowski, "Studies of the Electromagnetic Field Variations in ELF Frequency Range Registered by DEMETER Over the Sichuan Region Prior to the 12 May 2008 Earthquake," *International Journal of Remote Sensing*, **31**, 13, July 2010, pp. 3615-3629.
37. J. Blecki, M. Parrot, and R. Wronowski, "Plasma Turbulence in the Ionosphere Prior to Earthquakes, Some Remarks on the DEMETER Registrations," *Journal of Asian Earth Sciences*, **41**, 4-5, June 2011, pp. 450-458.
38. L. G. Bankov, M. Parrot, R. A. Heelis, J.-J. Berthelier, P. G. Marinov, and A. K. Vassileva, "DEMETER and DMS/P Satellite Observations of the Disturbed H⁺/O⁺ Ratio Caused by Earth's Seismic Activity in the Sumatra Area During December 2004," *Advances in Space Research*, **46**, 4, August 2010, pp. 419-430.
39. Y. He, D. Yang, H. Chen, J. Qian, R. Zhu, and M. Parrot, "SNR Changes of VLF Radio Signals Detected Onboard the DEMETER Satellite and Their Possible Relationship to the Wenchuan Earthquake," *Science in China Series D: Earth Sciences*, **52**, 6, June 2009, pp. 754-763.
40. J. Zlotnicki, F. Li and M. Parrot, "Signals Recorded by DEMETER Satellite Over Active Volcanoes During the Period 2004 August – 2007 December," *Geophysical Journal International*, **183**, 3, December 2010, pp. 1332-1347.
41. D. Piša, M. Parrot, and O. Santolík, "Ionospheric Density Variations Recorded Before the 2010 Mw 8.8 Earthquake in Chile," *Journal of Geophysical Research Space Physics*, **116**, A8, August 2011, A08309.
42. Y. He, D. Yang, J. Qian, and M. Parrot, "Anomaly of the Ionospheric Electron Density Close to Earthquakes: Case Studies of Pu'er and Wenchuan Earthquakes," *Earthquake Science*, **24**, 6, December 2011, pp. 549-555.
43. S. N. Walker, V. Kadiramanathan, and O. A. Pokhotelov, "Changes in the Ultra-Low Frequency Wave Field during the Precursor Phase to the Sichuan Earthquake: DEMETER Observations," *Annales Geophysicae*, **31**, 9, September 2013, pp. 1597-1603.
44. K. Ryu, E. Lee, J. S. Chae, M. Parrot, and K.-I. Oyama, "Multisatellite Observations of an Intensified Equatorial Ionization Anomaly in Relation to the Northern Sumatra Earthquake of March 2005," *Journal of Geophysical Research Space Physics*, **119**, 6, June 2014, pp. 4767-4785.
45. K. Ryu, M. Parrot, S. G. Kim, K. S. Jeong, J. S. Chae, S. Pulinets, and K.-I. Oyama, "Suspected Seismo-Ionospheric Coupling Observed by Satellite Measurements and GPS TEC Related to the M7.9 Wenchuan Earthquake of 12 May 2008," *Journal of Geophysical Research Space Physics*, **119**, 12, December 2014, pp. 10,305-10,323.
46. K. Qin, L. X. Wu, X. Y. Ouyang, X. H. Shen, and S. Zheng, "Surface Latent Heat Flux Anomalies Quasi-Synchronous with Ionospheric Disturbances before the 2007 Pu'er Earthquake in China," *Advances in Space Research*, **53**, 2, January 2014, pp. 266-271.
47. F. Němec, O. Santolík, M. Parrot, and J. J. Berthelier, "Spacecraft Observations of Electromagnetic Perturbations Connected with Seismic Activity," *Geophysical Research Letters*, **35**, 5, March 2008, L05109.
48. F. Němec, O. Santolík, and M. Parrot, "Decrease of Intensity of ELF/VLF Waves Observed in the Upper Ionosphere Close to Earthquakes: A Statistical Study," *Journal of Geophysical Research Space Physics*, **114**, A4, April 2009, A04303.

49. D. K. Cheng, *Field and Wave Electromagnetics*, Reading, MA, Addison-Wesley, 1989.
50. D. Piša, F. Němec, M. Parrot, and O. Santolík, "Attenuation of Electromagnetic Waves at the Frequency ~ 1.7 kHz in the Vicinity of Earthquakes Observed in the Upper Ionosphere by the DEMETER Satellite," *Annals of Geophysics*, **55**, 1, 2012, pp. 157-163.
51. D. Piša, F. Němec, O. Santolík, M. Parrot, and M. Rycroft, "Additional Attenuation of Natural VLF Electromagnetic Waves Observed by the DEMETER Spacecraft Resulting from Pre-seismic Activity," *Journal of Geophysical Research Space Physics*, **118**, 8, August 2013, pp. 5286-5295.
52. Y. He, D. Yang, R. Zhu, J. Qian, and M. Parrot, "Variations of Electron Density and Temperature in Ionosphere Based on the DEMETER ISL Data," *Earthquake Science*, **23**, 4, August 2010, pp. 349-355.
53. Y. He, D. Yang, J. Qian, and M. Parrot, "Response of the Ionospheric Electron Density to Different Types of Seismic Events," *Natural Hazards and Earth System Sciences*, **11**, August 2011, pp. 2173-2180.
54. D. I. Vavilov, D. R. Shklyar, E. E. Titova, and M. Parrot, "Study of the Lower Hybrid Resonance Frequency Over the Regions of Gathering Earthquakes Using DEMETER Data," *Journal of Atmospheric and Solar-Terrestrial Physics*, **100-101**, August 2013, pp. 1-12.
55. M. Li and M. Parrot, "'Real Time Analysis' of the Ion Density Measured by the Satellite DEMETER in Relation with the Seismic Activity," *Natural Hazards and Earth System Sciences*, **12**, September 2012, pp. 2957-2963.
56. M. Li and M. Parrot, "Statistical Analysis of an Ionospheric Parameter as a Base for Earthquake Prediction," *Journal of Geophysical Research Space Physics*, **118**, 6, June 2013, pp. 3731-3739.
57. X. Zhang, Z. Zeren, M. Parrot, R. Battiston, J. Qian, and X. Shen, "ULF/ELF Ionospheric Electric Field and Plasma Perturbations Related to Chile Earthquakes," *Advances in Space Research*, **47**, 6, March 2011, pp. 991-1000.
58. Y.-Y. Ho, J.-Y. Liu, M. Parrot, and J.-L. Pinçon, "Temporal and Spatial Analyses on Seismo-Electric Anomalies Associated with the 27 February 2010 $M=8.8$ Chile Earthquake Observed by DEMETER Satellite," *Natural Hazards and Earth System Sciences*, **13**, December 2013, pp. 3281-3289.
59. M. Akhoondzadeh, "Ant Colony Optimization Detects Anomalous Aerosol Variations Associated with the Chile Earthquake of 27 February 2010," *Advances in Space Research*, **55**, 7, April 2015, pp. 1754-1763.
60. S. Louerguoui, S. Gaci, and N. Zaourar, "Irregularities of the Ionospheric Plasma and the ULF Electric Components Obtained from **DEMETER** Satellite Experiments Above Chile **Earthquake** (27 February 2010)," *Arabian Journal of Geosciences*, **8**, 5, May 2015, pp. 2433-2441.
61. X. Shen, X. Zhang, L. Wang, H. Chen, Y. Wu, S. Yuan, J. Shen, S. Zhao, J. Qian, and J. Ding, "The Earthquake-Related Disturbances in Ionosphere and Project of the First China Seismo-Electromagnetic Satellite," *Earthquake Science*, **24**, 6, December 2011, pp. 639-650.
62. Anonymous, Prediction of the Haicheng Earthquake, *Eos, Transactions American Geophysical Union*, **58**, 5, May 1977, pp. 236-272.

Topology Control of a Network of Autonomous Aerial Drones

Daniel Camara

Criminal Intelligence Service of the French Gendarmerie (STRJD)
Gendarmerie Nationale Ministère de l'Intérieur Pontoise, Val-d'Oise, France
E-mail: daniel.camara@gendarmerie.interieur.gouv.fr

Abstract

This paper discusses the use of a fleet of fully automated aerial drones for relief efforts. In particular, we focus on the use cases of such a fleet, and the minimum requirements such that the drones can be effectively useful over disaster scenarios. After that, the paper presents a proposal for an autonomous topology management algorithm that is capable of maintaining a mission-based network topology. The algorithm is simple, yet capable of adapting to different requirements. It is capable of enforcing a stable topology even if all the nodes behave selfishly.

1. Introduction

In general, disaster scenarios are chaotic places, mainly for the first wave of relief-effort teams. Access may be hard, and the resources for the rescue-operation teams may be relatively limited. The first hours after a disaster are the hours where we have the biggest probability of finding people alive, but unfortunately, these are also the more turbulent hours. Communication capabilities in the target region may be lost, the very map of the region may be outdated, and access to areas may have been compromised by, e.g., debris, flooded roads, or collapsed buildings. This

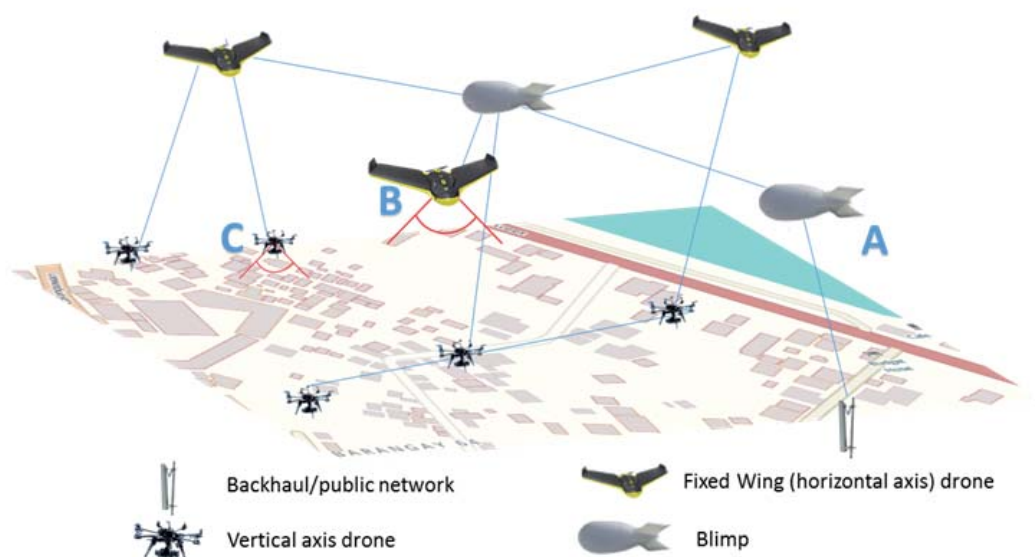

Figure 1. An example of the deployment of a mission-based airborne network, where different nodes perform different tasks, providing different kinds of information and services. A is a blimp squadron, which is stable and has a large autonomy. It can be used as a network backbone to provide connection to the other nodes. B is a fixed-wing node that can be used to take aerial photos, to automatically determine the up-to-date cartography of the affected region. Node C is a vertical-axis drone, which can hover over a specific point, trying to sense signals and pinpoint possible survivors.

combination of factors, plus the scarcity of human resources and the feeling of urgency in finding/contacting affected people demands an efficient and organized set of measures. Some of these measures typically require specialized rescue professionals, but automated drones could perform others. This would free the rescuers from their burden, and let them focus on the tasks for which their attention is fundamental.

The tasks drones can excel at performing are normally non-intrusive tasks. For example, they can go from providing network access over the affected area and automatically mapping the changes in the region's topography, to the detection of victims using a series of distinct sensors. Figure 1 shows a possible topology for drones where different drones perform different tasks over a defined area. It should be noted that we should always try to use the right tool to perform the task at hand: different tasks may require different drones. However, one thing is general: over disaster scenarios, drones should always be as autonomous and independent as possible, so that they are operational without draining the scarce human resources. By autonomous, we mean that drones should have their own missions to perform, and they complete each mission or set of missions without any human interference. Ideally, they would receive their mission or set of missions and their priorities from the command operation center, work on each one until it is fulfilled, and at this point, demand a new set of missions. As much as possible, the drones should be autonomous: even tasks such as recharging should be automatic, so that

they are performed without human interference. This is an important point, because independently from the powering model used, e.g., electric or internal-combustion engines, the available energy is always limited and, at some point, it will end. Moreover, drones may continuously work on their missions 24/24, fulfilling mission after mission. On the other hand, human operators cannot, so it is reasonable to assume the presence of automatic mechanisms to optimize the availability of drones.

In this paper, we will talk about autonomous topology control for mission-based aerial drones. We understand the mission as being a well-defined task that can be autonomously performed by the drones. The missions could be as varied as providing a temporary communication structure, creating up-to-date maps of the affected region, or even searching for hot spots where the rescue teams may have more chances of finding victims. We will provide the topology and connection requirements drones should satisfy to be able to address these and other missions.

2. Related Work

Airborne networks are wireless-communication networks formed by nodes such as satellites, balloons, drones, or fixed-wing aircraft. Figure 2 shows some of the technologies that can be involved. These kinds of networks have their origins in military environments,

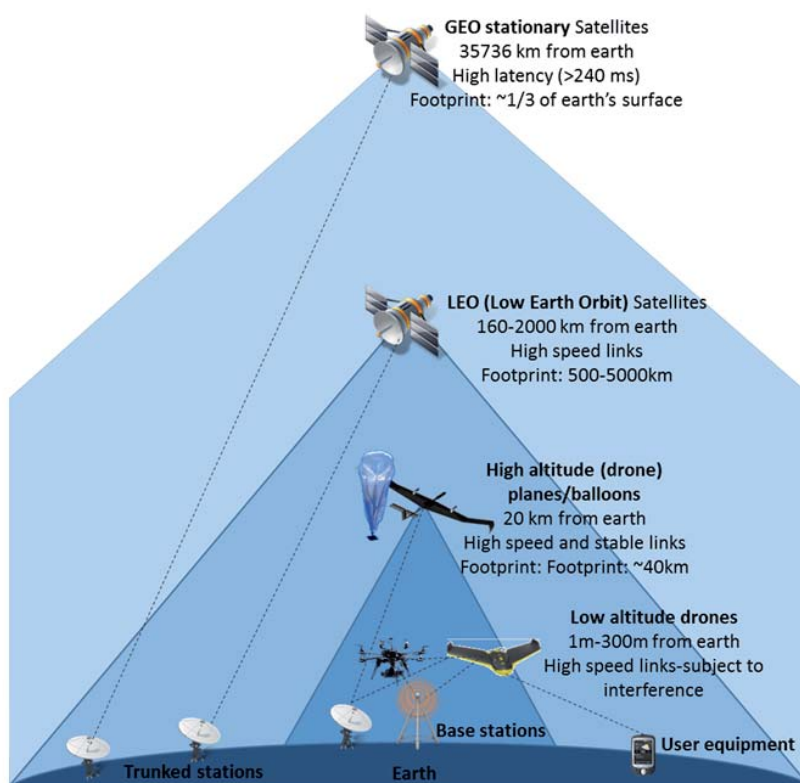

Figure 2. The main available aerial-communication methods to be used in disaster scenarios.

where flying nodes are used to create an access network over hostile environments. However, we recently have seen the development of civil interest in drone networks. For example, Google's Loon [1] wants to provide Internet access to populations without access. The project seeks to create a hierarchical airborne network of high-altitude balloons, traveling on the edge of space, around 20 km above the Earth's surface. At this altitude, the balloons will move with the wind currents in the upper atmosphere to provide access to connect people in rural and remote areas, to help fill coverage gaps, and to bring people back online after disasters [2]. The intention is to establish partnerships with local telecommunications companies to share cellular spectrum, and to enable directly connecting to the balloon network with LTE-enabled devices. The signal is then routed over the balloon network and, at some point, back down to the global Internet on Earth. Each balloon can provide connectivity to a ground area of about 40 km in diameter.

Facebook has also demonstrated interest in flying technologies to provide Internet access to uncovered areas. They recently acquired Ascenta, a UK-based company that designs solar-powered drones. Mark Zuckerberg, the head of Facebook, wrote a post stating they are "working on ways to beam Internet to people from the sky" [3]. In a press release [4], they discussed some of the different technologies that can be used for offering aerial solutions for connectivity, and that different populations have different needs. However, taking into account the series of restrictions and challenges for a project this big, a network of drones operating at 65,000 feet (~20 km) is viewed as an ideal access-providing mechanism. Although not many of the techniques used to interconnect the drones and the different technologies have been released, among the advantages for a drone network stated in the press release are the following [5]:

- With the efficiency and endurance of high-altitude drones, it is even possible that an aircraft could remain on the air for months or years, much longer periods than their balloon counterparts.
- Unlike balloons that drift on the wind with limited controls, drones can remain over a specific city or area.
- In case of need for maintenance, drones can be easily returned to Earth and redeployed.

The topology management and control of airborne networks is a critical subject for network success, giving the dynamic nature of the network. The links among the nodes must be easily and quickly reconfigurable to respond to the mobility of the flying nodes. Aerial nodes can often change flight paths and missions. Moreover, sudden changes in climatic conditions may have great influence on the mobility of the nodes. Automatic and dynamic topology-management mechanisms play a fundamental role in maintaining network connectivity. Even though still a young research field, different organizations, with different objectives,

were proposed in the context of airborne networks. Milner et al. [6] proposed the formation of a backbone network with airborne networking platforms (ANPs) to enhance the reliability and scalability of tactical networks. This set of airborne networking platforms may be seen as mobile base stations with predictable and well-structured flight paths. The possible combat aircraft on a mission are the mobile clients. The topology-control mechanism proposed there can be used to maintain such a topology, but it goes even further in the sense that it automatically adapts to different kinds of missions. Controlling a small set of configuration parameters, one can not only maintain a backbone, but can also change the way the other nodes are interconnected, taking into account the mission at hand. We are interested in maintaining a stable connected network for the backbone, but we also want our topology-management mechanism to handle the connectivity of the drones in the mission, whether or not in a specific formation.

A relatively simple way to improve network connectivity is to have large transmission ranges for the airborne networking platforms. However, a large transmission range also implies a high power consumption. In order to decrease the power consumption, targeting the improvement of the network lifetime and the autonomy of the drones, one can control the power of the transmission to decrease the range of the nodes. The smaller the range, the smaller also is the interference among users. However, in this case the role of the topology-management mechanism in maintaining the connectivity becomes even more important. In [7], Shirazipourazad, Ghosh, and Sen defined a critical transmission range (CTR) to be the minimum transmission range of the airborne networking platforms necessary to ensure that the dynamic network formed by the movement of the airborne networking platforms remained connected at all times, even in the presence of attacks and node failures. However, they mainly targeted one specific scenario: providing access to other aerial nodes. They also considered that the full network flight plan was known in advance, and did not greatly change during the mission. That is a strong assumption, mainly for drone networks in disaster areas.

In [8], Krishnamurthi et al. presented MAToC (Mission Aware Topology Control), a topology-control mechanism for the backbone of airborne networks. MAToC uses a distributed protocol to exchange the flight plans of the nodes, and uses these collected plans to assign optimal power, channel, and boresight directions to the airborne antennas. MAToC uses a geometric optimization methodology to assign antenna powers to maximize signal-to-interference-and-noise ratio (SINR). It also constantly monitors the links, searching for broken links to afterwards fix them. The feedback comes either through the routing layer or through proactive Hello/Hello-Ack messages. To ensure the connectivity of the airborne network, backup links are maintained to replace possible faulty links. Link failure can occur in highly dynamic airborne networks because of factors such as mobility, interference, or jamming. A well-

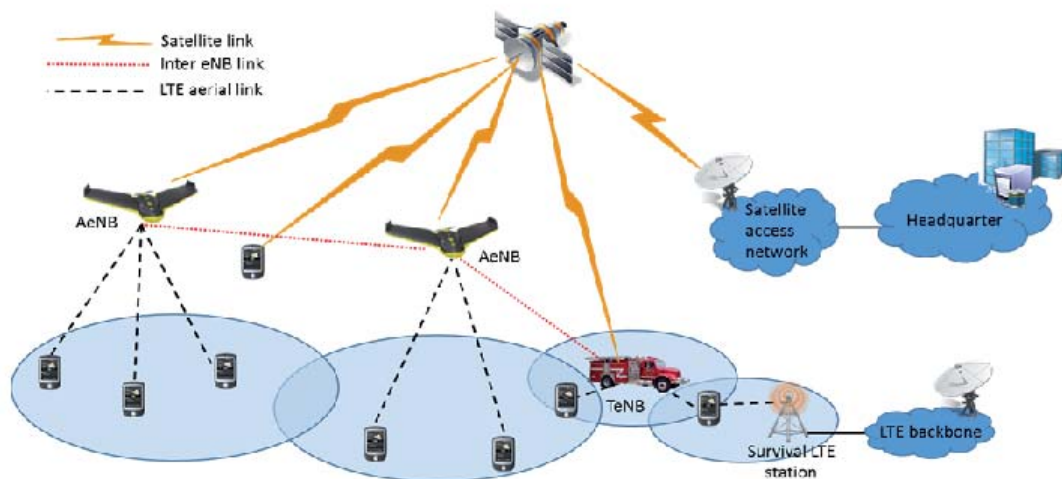

Figure 3. The ABSOLUTE project: the main defined scenario components and their relationships.

known solution is to maintain a secondary communication channel that can be set up when the original link fails [8]. One of the main ideas behind MAToC is that in networks that utilize omnidirectional antennas – typical on networks composed of tactical aircraft – the only means of controlling the topology is by varying the transmitted power. While keeping a high transmitted power may improve connectivity and reduce the number of hops required through a network, it also increases the interference and complexity of routing. However, Krishnamurthi, et al. do not consider that other solutions, such as different frequencies and dual radios, could also be considered.

Midkiff and Bostian [9] presented a two-layer network-deployment method for organizing public-safety networks (PSNs). Their network consisted of a hub and possibly many purpose-specific routers to provide access to nodes in the field. In some sense, our work provides the same kind of topology, since we are interested in the backbone creation to provide access for the end nodes, e.g., firefighters in the field. However, the work of Midkiff and Bostian had two characteristics that we want to avoid. First, the hub represents a single point of failure. If something happens to it, all the communications would be down, even between nodes inside the field. It is important for public-safety networks to be as resilient as possible. The second issue we want to avoid if possible is long-range communications, and the fact that all transmissions pass through the hub. One of the objectives of this work is to avoid as much as possible single points of failure, while ensuring the availability of local communications. Narrowing communications to the areas they are really needed, we save resources for other transmissions that really need to cross the network.

The EU FP7 ABSOLUTE [10] investigated the possibility of deploying a hybrid aerial-terrestrial network architecture, in order to provide LTE broadband

communications over a large disaster area. Access would be granted using specific-purpose aerial eNB (AeNB) and a low-altitude platform (LAP) to provide aerial coverage to a large area, and a portable lightweight terrestrial eNB (TeNB) to enhance network capacity in hotspot areas. The radio spectrum is supposed to be shared between multiple AeNBs or TeNBs. The architecture, depicted in Figure 3, was intended to provide fast deployment and LTE accessibility during disasters or temporary events. In [11], Zhao and Grace proposed a flexible topology management for the architecture proposed by the ABSOLUTE project. The topology-management proposal was based on the activity in a given area: the greater the traffic, the better the coverage in the area. They also proposed to use information from the satellites to provide the first hint of where to deploy the available AeNBs and TeNBs. After that, the algorithm positions the stations based on the probability of message retransmissions. If a given TeNB becomes inactive below a given threshold, it is removed from that low-use area and deployed into another area.

3. Topology-Control Requirements for Network Reliability

In short, topology management, or topology control, is the process of building and maintaining a given network topology. Santi [12] highlighted that it is related to the dynamicity of the nodes, and the control of transmission power to save energy and to control network density. Having a well-organized and predictable network structure greatly simplifies the work of the algorithms of upper layers, and the stability of the network. Whether centralized or distributed, i.e., acting globally or locally, topology-management mechanisms have a systemic impact as they organize the network as a whole.

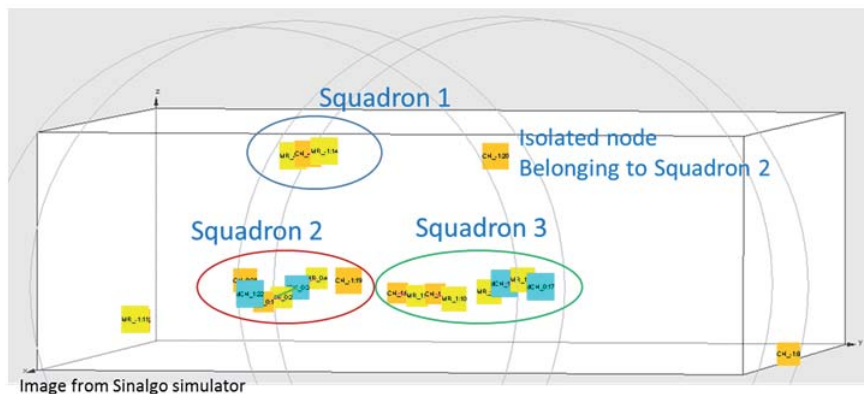

Figure 4. An image from the simulation of an experiment with three squadrons.

Bearing in mind the need for self-organizing MANET-like networks, this work intends to contribute to the development of an efficient and customizable autonomous topology-control mechanism. Before proceeding to details of the proposed method, we want to present the characteristics that a topology-management algorithm should present. To be useful the topology-control (TC) algorithm should:

- Control the number of nodes offering a given service/ having a specific role. For example, in an LTE network, eNBs are responsible for providing access and organizing the traffic in their cells, whereas UEs could be used as relays.
- Perform the topology reconstruction to reach a stable configuration, while respecting the desired topology.
- Ensure stable, or at least as stable as possible, topologies.
- Produce well-balanced network topologies, where no node is overloaded.

4. Topology Management for Mission-Based Aerial Networks

4.1 Mission-Based Topology Description

The topology-management method proposed here targets the control of mission-based aerial-drone networks. The network nodes have a predefined mission, and a squadron leader that is responsible for the squadron. During the mission, squadron nodes work as a cluster. The squadron leader also works as the cluster head, organizing the communications inside the cluster. We will indistinctly use cluster head and squadron leader here, as from the point of view of the network, their function is the same. However, the squadron leader is assigned before the start of the mission, while the cluster head is a temporary role nodes

assume to provide connection to him and to the other nodes in his neighborhood. Each squadron has a specific mission that differs among squadrons and during the time of the operation. As an example of missions, we could cite roving over specific points to provide access to ground-rescue teams, or scanning a delimited geographic area searching for survivors. In general, nodes in the same cluster present similar patterns, and tend to be close each other.

Each squadron has his own identifier, and the flying nodes connect to the leader of their squadron based on this identifier. During the mission, if the squadron gets split and part of the squadron gets out of the range of the leader, a new leader for the squadron needs to be elected. The new leader should be the drone with more resources. When two sub-squadrons are in communication range of each other, they should merge.

At the merge, the original leader always has the preference. In the absence of this, the node that is serving as leader to more nodes should become the leader. In case of a failure of the leader node, an election should again take place, and once more the winner should be the node with more resources. Whenever a node becomes isolated or far from its leader, it becomes a leader, and connects to the other leaders in the region. If it enters into a region covered by another leader with a higher rank, the node gives up being a leader and asks the high-ranked leader to join its group. Figure 4 shows an image extracted from the Sinalgo simulator, with three defined squadrons flying together.

4.2 The Bases of the Proposed Method

The method we propose to fulfill the requirements listed in Section 3 to control the network described in the previous section uses a market-based approach. This approach uses a heuristic that is based on economic concepts. The strategy we describe here relies on the laws of supply and demand to dynamically organize the network structure. In his book, *The Wealth of Nations*, Adam Smith said, “It

```

1. The node arrives in the network (IN, mySquadron); //isolated node, present squadron identifier
2. The node broadcasts a Connection request (mySquadron) message;
3. Waits for responses;
4. If (receives any Connection response from a possible provider) {
5.     Weights the costs of the responses;
6.     Sends a Connection confirmation to the provider with the lowest cost;
7.     Becomes a MR; // Mobile router
8.     Go to step 17
9. } Else{
10.    If(the number of trials smaller than 3){
11.        Returns to Step 2;
12.    }Else{
13.        Becomes an CH; //Cluster Head
14.        Sends a Connection Update;
15.    }
16. }
17. Starts the broadcast timer;
18. Starts the evaluate_update timer;
19. Triggers TreatBroadcastTimer();
20. While(running){
21.    Waits for messages or broadcast timer to expire;
22.    If(broadcast timer expired)
23.        Calls TreatBroadcastTimer();
24.    If(a Connection Request is received and squadronID == mySquadronID){
25.        Answers with a Connection Response, informing present connections;
26.    }Elseif(a Connection Confirmation is received){
27.        Registers the connection;
28.        Reevaluates present state {
29.            If (is a MR) {
30.                Becomes a CH;
31.                Sets the price to the basic CH price;
32.            } Elseif (is a aCH){
33.                Increments the price;
34.            }
35.        }
36.    }Elseif(a Connection Response is received){
37.        If( the response node cost is lower than the present one){
38.            Sends a Connection Confirmation;
39.            Registers the received Update
40.            Registers the new connection;
41.            Reevaluates state (if a CH, becomes a MR);
42.            Sends a Connection Cancel present CH;
43.        }
44.    }Elseif (a Connection Update(squadronID) is received){
45.        If(squadronID == mySquadronID)
46.            Registers the received Update, ;
47.    }Elseif(a Connection Cancel is received){
48.        Removes the related connection;
49.        If(the removed connection is to the current provider (CH)){
50.            Becomes an IN;
51.            Returns to 1;
52.        }
53.    }
54.    If(evaluate_update timer expired){
55.        Evaluate Updates to find better providers;
56.        If(found better provider)
57.            Sends a Connection Request(mySquadronID);
58.    }
59. } // While
60. function TreatBroadcastTimer(){
61.    If(state is CH){
62.        Broadcasts a Connection Update(mySquadronID).
63.        Returns to 17;
64.    }
65. }

```

Figure 5. Algorithm 1: A high-level algorithmic description of the market-based topology control for aerial drones. The mysquadronid variable is a predefined squadron identifier.

is not from the benevolence of the butcher, the brewer, or the baker that we expect our dinner, but from their regard to their own interest” [13]. As we will show, just as in Adam Smith’s statement, even though nodes behave selfishly, using the market-based approach they manage to reach the best possible allocation, as it fits their own interests.

The three laws of supply and demand can be described as follows [14]:

- When demand is greater than supply, prices rise, and when supply is greater than demand, prices fall.
- The greater the difference between supply and demand, the greater the force on prices.
- Prices tend to an equilibrium point, called a Walrasian equilibrium, at which supply equals demand.

Going back to the topology-control algorithm requirements from Section 3, we can map the need to control the number of clusters to the first law of supply and demand.

We thus associate a cost with the services the node requests from/provides to others, i.e., a basic communication price. At any given time, different providers may have different prices, depending on both their type and load. By controlling the prices of different services offered in the network, we can control the number of nodes offering each. Regardless of the exact pricing scheme, the proposed mechanism emulates a free market, where each agent – i.e., each node – is assumed to be rational, and to selfishly choose its consumption to maximize its utility. On the one hand, nodes thus constantly monitor the market in search of a smaller communication price, and switch whenever possible to cheaper service providers: what reduces the cost of their previous provider, but increases the cost of communication prices with the number of nodes they are attending. However, if these prices become too high, they will start losing customers out to their competitors. In some conditions, client nodes may even decide to themselves become providers (thereby initiating new clusters): the new cluster, which tends to reach an equilibrium.

The network is also required to converge to a stable state as fast as possible. The need for an equilibrium can be related to the third law of supply and demand. The second law implies that the greater the differences between supply and demand, the greater the force on prices, and the faster the resulting convergence.

In fact, any free or competitive market such as the market we just described, under conditions, leads to a Walrasian equilibrium [15]. This equilibrium point is also a Pareto optimal arrangement, where no changes in the allocation of goods and services can benefit a participant without causing damage to others. This follows from the first theorem of welfare economics [15]:

- [A1] The market for all possible goods exists and there are no externalities present, i.e., all costs and benefits are transmitted through prices. In our model, the only price is the price given by the pricing formula.
- [A2] The market is perfectly competitive and no participant has enough power to influence the prices. This is also satisfied by our setup, since the possibility of clients themselves becoming providers is a mechanism that breaks any potential monopoly.

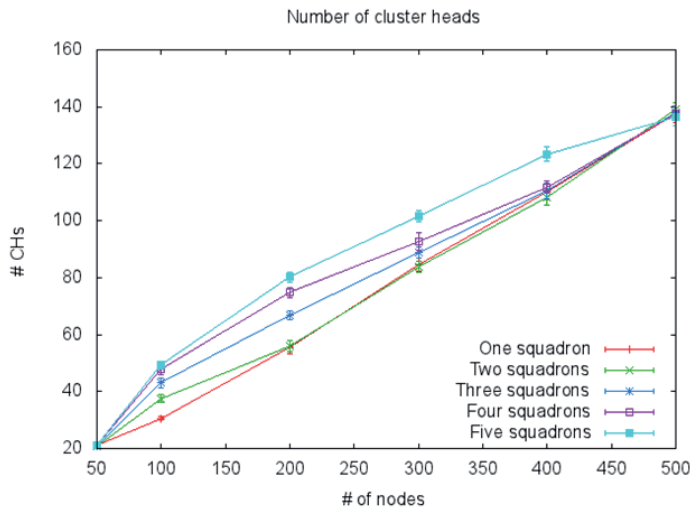

Figure 6. The average number of cluster heads over the network.

- [A3] The cost of transactions is negligible. There is no hidden cost attached to the transactions.
- [A4] Market participants have perfect information, all agents are rational and have access to full information about all products at all times. This is ensured by having prices for every possible provider and node type frequently exchanged among the nodes.

A globally fair and efficient allocation of resources and the corresponding equilibrium point is thus achieved in a competitive market when supply equals demand for any good or service traded among the peers: in our case, the connection/communication with the rest of the network. Algorithm 1, shown in Figure 5, presents a broad view of the protocol put in place for controlling the topology of the nodes over the experimental section. All nodes apart from the squadron leaders start as isolated nodes (IN). These isolated nodes try to find a leader (cluster head, CH), from the same squadron. If they find a cluster head, they attach to this leader; if not, they become one. Nodes have two interfaces. The first is to talk to the nearby nodes in the same group. The second interface is used only by the group leaders to connect to other group leaders. This second interface

has a larger range and intends to interconnect the various clusters. It thus is accessible to all nodes, independently of their squadron and size.

5. Experiments

The evaluations were carried out using the Sinalgo simulator [16] in a space of 3000 m × 3000 m × 2000 m, where nodes ran for two simulated hours. The simulations were conducted with ranges of 400 m and 700 m for interfaces one and two, respectively. All experiments were conducted using *Linux Ubuntu 14.04.1 LTS* on an Intel Xeon W3670 3.20 GHz twelve-core machine, with 12 GB of RAM. All graphs are presented with a confidence interval of 99%, and each point is the result of averaging over at least 34 runs with different network configurations. The nodes arrived randomly, and were placed near to their squadron leader. Nodes have a tendency to follow their leaders, but this tendency was not fully enforced by the mobility model. For the experiments, nodes flew over the area following a normal random-way-point speed distribution, where the average was 10 km/h and, on average, nodes kept one direction per at least 20 s.

Figure 7. The average number of nodes connected to form a cluster during the simulation period.

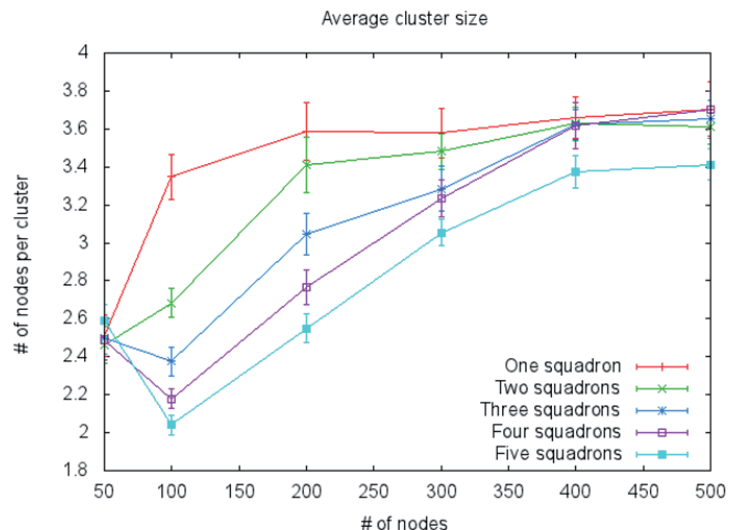

Parameter	Value
Simulator	Sinalgo
Simulation time	2 hours
Area (L×W×H)	3 km × 3 km × 2 km
Interface 1 range	400m
Interface 2 range	700m
Percentage of loss messages	0.01%
Average speed	10 km/h
Number of squadrons	1,2,3,4,5
Prices to connect	DH:0, CH:5, MR:15
Max cluster size	16 nodes

Table 1. The main simulation parameters.

Nodes were divided into squadrons. Regular nodes (mobile routers, MR) from different squadrons did not directly talk to each other: the communication needed to go through the cluster heads, which could transfer messages through the second interface. Table 1 summarizes the main simulation parameters used over the experiments.

The main objective of the experiments was to show that the market-based approach could effectively be used to control the topology of aerial drones. Here, we used the market-topology control to organize the network into a two-layer hierarchical structure, but other kind of organizations are also possible. The graph in Figure 6 presents the number of cluster heads when we varied the density of nodes and the number of independent squadrons in the same area. We could perceive that the number of cluster heads, the nodes responsible for organizing the network, was linked to the number of nodes in the network. We could also perceive that the larger the number of squadrons, the larger the number of cluster heads. This was expected, as the nodes could only

exchange information and connect to clusters within the same squadron. The larger the number of squadrons, the smaller was the probability of finding a cluster around in the same squadron, and thus the number of cluster heads to manage the different squadrons grew.

Figure 7 presents the average size of the clusters. We could perceive that they stabilized around 3.5 nodes per cluster. This was linked to the mobility model used. Nodes when flying together tended to form stable clusters, but as the random direction mobility model did not enforce the formation, clusters tended to split, and nodes changed from one cluster to another. We could also observe the clear influence of the number of squadrons over the size of the clusters. The bigger the number of squadrons, the smaller the cluster sizes.

With the mobility, part of the nodes tended to become cluster heads. However, they did not provide connection services to any other node, i.e., no other node attached to them. This was a regular and expected behavior. However, it should kept low, since these stand-alone cluster heads represented a cost in terms of control messages, which helped to decrease the network's autonomy and hardened the access to the medium. Figure 8 shows the average number of standalone cluster heads over the whole simulation time, taking into account the size of the network and the number of squadrons. For small densities, the number of standalone cluster heads tended to be stable, and linked to the number of squadrons acting in parallel over the target area. With an increase in the network density, nodes also tended to spread and move more over the target region, and this increased the number of nodes that become cluster heads to try to maintain the connection with the rest of the network.

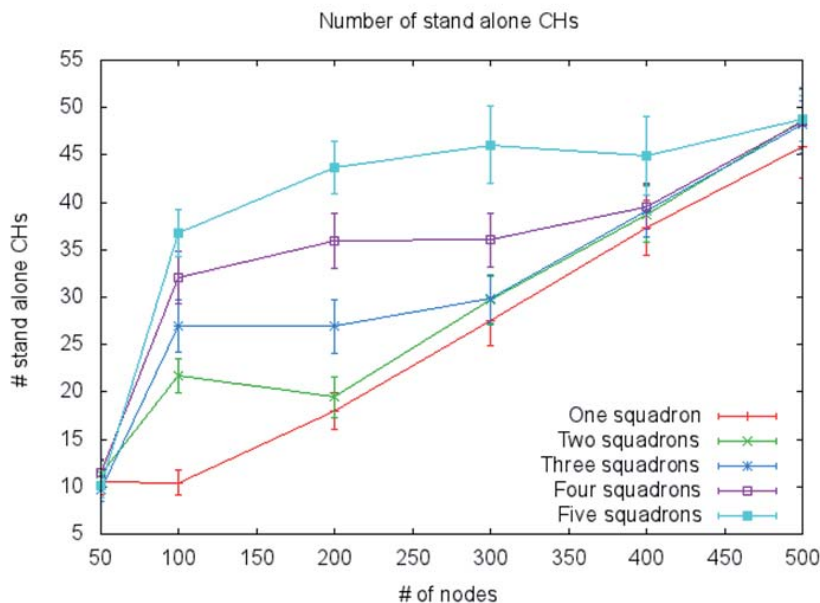

Figure 8. The average number of standalone clusters during the simulation period.

6. Conclusions

To be effective in a disaster scenario, rescuers require a set of information and services, for example, up-to-date geographical information and network-connection capabilities, among others. Aerial drones may fulfill part of these needs. In the future, aerial drones may become an invaluable tool for providing a number of different services and providing information to help with disaster-relief efforts. However, to be effective, the organization of the different kinds of nodes needs to be as autonomous as possible. The network should work with the least human interaction possible. Among the tasks that should be accomplished autonomously by the nodes is the auto-organization of the network.

This paper discussed the problem of creating and maintaining a stable network topology for aerial-drone networks. We presented different initiatives and methods, and we discussed how a market-based heuristic could be used to control the topology of a significantly large aerial-drone network. The presented method, which was based on the economics principles of offer and demand, successfully organized the topology, even in presence of honest selfish nodes. We called them honest because they did not try to cheat on their prices to attract/refuse connections. On the other hand, they were selfish because they tried to get the best connection cost possible. For this reason, they were constantly searching for the “best deals” among the clusters in the region in which they were.

The network tended to a stable point, where all the clusters had more or less the same price, and where it was not worth changing providers. However, as the prices were linked to the number of nodes being served by a cluster – and nodes moved, leaving old clusters and connecting to new ones – the prices varied, and nodes entered in concurrency. It was interesting to note that even in a selfish environment, we could foster collaboration. In this competitive environment, we only set the basic prices to different types of services, and we let the nodes decide if they were or were not willing to pay the price. Nodes did not collaborate to form a stable and consistent topology because they were altruistic. They collaborated because they could gain something with this collaboration, in this case, “paying” less for their connection. Instead of penalizing collaboration, this simple fact fostered it. Nodes then had a reason to collaborate, and even to behave well toward each other.

The topology was relatively stable, but more experiments need to be made in order to evaluate the impact of the technique with more realistic mobility models and different mission-based scenarios.

7. References

1. R. Devaul, E. Teller, C. Biffle and J. Weaver, “Balloon Network with Free-Space Optical Communication Between Upper-Node Balloons and RF Communication Between Super-Node and Sub-Node Balloons,” Patent PCT/US2013/020705, July 18, 2013.
2. “Balloon-Powered Internet for Everyone,” <http://www.google.com/loon/>, last visited July 07, 2015.
3. Juliette Garside, “Facebook Buys UK Maker of Solar-Powered Drones to Expand internet,” *The Guardian*, <http://www.theguardian.com/technology/2014/mar/28/facebook-buys-uk-maker-solar-powered-dronesinternet>, March, 28, 2014, last visited July, 07, 2015.
4. Mark Zuckerberg, <https://www.facebook.com/zuck/posts/10101322049893211>, March, 27, 2014, last visited July, 07, 2015.
5. “Connecting the World from the Sky,” internet.org press release, March 28, 2014.
6. S. Milner, S. Thakkar, K. Chandrashekar, and W. Chen, “Performance and Scalability of Mobile Wireless Base-Station-Oriented Networks,” *ACM SIGMOBILE MC2R*, 7, 2003.
7. S. Shirazipourazad, P. Ghosh, and A. Sen, “On Connectivity of Airborne Networks in Presence of Region-Based Faults,” *Military Communications Conference, MILCOM 2011*, November 2011, pp. 1997.
8. Niyant Krishnamurthi, Anurag Ganguli, Abhishek Tiwari, Bao-hong Shen, Joseph Yadegar, and Gregory Hadynski, “Topology Control Within the Airborne Network Backbone,” *MILCOM 2009*, *Military Communications Conference*, Boston, MA, October 18-21, 2009.
9. S. F. Midkiff and C. W. Bostian, “Rapidly-Deployable Broadband Wireless Networks for Disaster and Emergency Response,” *First IEEE Workshop on Disaster Recover Networks*, June 2002.
10. “FP7 ABSOLUTE, Aerial Base Stations with Opportunistic Links for Unexpected and Temporary Events,” <http://www.absolute-project.eu>, last visited July 07, 2015.
11. Q. Zhao and D. Grace, “Dynamic Topology Management in Flexible Aerial-Terrestrial Networks for Public Safety,” *2014 1st International Workshop on Cognitive Cellular Systems*, Germany, September 2-4, 2014.
12. P. Santi, *Topology Control in Wireless Ad Hoc and Sensor Networks*, New York, Wiley, 2005.
13. Adam Smith, *An Inquiry into the Nature and Causes of the Wealth of Nations*, W. Strahan and T. Cadell, London, 1776.
14. Jonathan Levin, *General Equilibrium*, Harvard University Press, 2006.
15. Gerard Debreu, *Theory of Value: An Axiomatic Analysis of Economic Equilibrium*, New York, John Wiley & Sons, 1959, ISBN 0-300-01558-5. ISBN:0-300-01558-5.
16. Sinalgo – Simulator for Network Algorithms, distributed computing group at ETH Zurich, <http://disco.ethz.ch/projects/sinalgo/>, last visited July 10, 2015.

Designing Autonomous Crawling Equipment to Detect Personal Connected Devices and Support Rescue Operations: Technical and Societal Concerns

Tullio Joseph Tanzi¹, Olivier Sebastien², and Caroline Rizza³

¹Institut Mines - Telecom - Telecom ParisTech. LTCI UMR 5141 CNRS, France
E-mail: tullio.tanzi@telecom-paristech.fr

²Laboratoire d'Informatique et de Mathématiques Université de la Réunion, France
E-mail: olivier.sebastien@univ-reunion.fr

³Institut Mines - Telecom - Telecom ParisTech I3 UMR 9217 CNRS, France
E-mail: caroline.rizza@telecom-paristech.fr

Abstract

Gathering and processing reliable information is a major aspect in disaster management. That is why information technologies have used been more and more for this purpose. Currently, two new trends seem to emerge. On the one hand, personal digital devices, such as smartphones, tablets, and smart watches are becoming more and more popular. On the other hand, the range of application of autonomous civilian drones and robots is becoming wider than before.

One can therefore make use of the latter to quickly detect the former when a crisis occurs, given the hypothesis that connected devices are nowadays mainly attached to a person rather than a place, as in the past. This paper thus aims at studying the technological and ethical, legal, and social questions that such a methodology raises. We propose to frame our forthcoming research into an “ethics-by-design” approach, which will be supported by anticipating effective operational uses (an information-technology-appropriation approach).

1. Introduction

In our field of research, there are problems that integrate the ethical, legal, and social (ELS) aspects more than others. The topic we propose to focus on in this article is

clearly one of them. Let us consider an example to illustrate this fact. Using drones to assist victims in an area where a war occurs can lead to unexpected behaviors from civilians (fear, panic, or even aggressiveness), because the civilians can consider the UAV (unmanned aerial vehicle) a threat. They might have seen or been told of military drones, such as the Predator, which are weapons: hence, the “Predator Syndrome.” For several non-technical reasons such as this, research efforts toward a humanitarian drone cannot be made without taking into account the ethical, legal, and social aspects from the conception stage to the terrain experiments. Social sciences thus allows raising questions and giving clues about the best solutions to address the problem globally: that is to say, technically and non-technically speaking.

In a 2012 staff working document about “A European Strategy for the Development of Civil Applications of Remotely Piloted Aircraft Systems (RPAS),” (Commission Staff Working Document, 2012 [1]), the European Commission identified the usefulness of drones for crisis management, and their potentials in completing global monitoring for environment and security (GMES), as well as in becoming part of a European disaster surveillance system [1, p. 18]. More recently (in 2014), the European Commission [2] reaffirmed the “societal benefits of this innovative technology.” It also shed light on the social and ethical aspects this technology raises, namely, safety, privacy and data protection, third-party liability and insurance or security concerns.

In a context of crisis, drones can support societies in dealing with uncertainty. Tanzi and Isnard [3], and Tanzi and Lefeuvre [4] explained how in the post-disaster phase drones can collect information not necessary accessible without their intervention. They consequently can support a more relevant and adapted response to the crisis. The authors underlined the required advanced capacities (e.g., energy and decision-making) necessary to design and implement autonomous drones for rescue missions. In collaboration with humanitarian organizations (French “Protection Civile;” Médecins Sans Frontières, MSF; International Committee of the Red Cross, ICRC; etc.), they have identified three main scenarios:

1. The automatic coverage of a geographical area, including a devastated area;
2. The identification of groups of victims and their classification (e.g., adults/children);
3. The automated search for buried victims (in rubble, for instance), or for lost persons in difficult areas, such as forests, based on the electromagnetic radiation from the victims’ personal items (e.g., smartphones).

As underlined by European Commission official documents, a literature review in the field, and the practitioners, there are potentials and societal benefits in using drones in crisis situations, but at the same time, ethical, legal, and social issues (ELSI) arise. In this paper, we propose to adopt a dialectic position in order to shed light on these opportunities and challenges.

Our paper is structured as follows. First, a literature review frames the ethical, legal, and social concerns raised by such use: 1) data protection and privacy concerns when using victims’ smartphones to locate them; 2) equality and social-justice issues related to the digital divide, and the consequent risk of forgetting non-equipped victims; 3) safety, liability, and responsibility issues in the case of technical failure and victims’ injuries. We also present design approaches (e.g., “responsible research and innovation,” “ethics-by-design,” and “design in practice”) for information-technology (IT) supported crisis management and response.

Second, based on the Labsoc (Telecom ParisTech, Nice Sophia Antipolis) research work on autonomous humanitarian drones for rescue operations, we present the capabilities of drones for crisis management and response. More specifically, we shed light on how drones constitute an asset for coordination centers and rescue teams for both communication and detection activities [5]. For the activities of communication/ coordination, site/ground investigation, search and rescue operation, and autonomous victim detection, we identify and assess the opportunities and challenges of drones. In our work, we have made the hypothesis that there is a strong link between a victim and a communicating device (e.g., a mobile phone) that he/she owns. Consequently, the detection of electromagnetic

waves emitted by these objects will make it possible to locate victims and to guide rescue teams during their intervention. We are also convinced that the autonomy of drones is required to fully assist and contribute to rescue operations.

The third part discusses the societal challenges raised by our research work. We conclude by framing our forthcoming research into an “ethics-by-design” process, supporting the design and implementation of autonomous drones for rescue operations, and framing/anticipating their uses by taking into account (from the design to the appropriation phase) the ethical, legal, and social considerations they raise.

2. State of the Art

In this first section, we would like to present the state of the art (1) related to what we have identified as the ethical, legal, and social issues raised by the design and use of autonomous drones for crisis management and response – mainly privacy, social justice and safety concerns; and (2) focused on design methods we consider relevant and useful for our work.

2.1 Autonomous Non-Human Agents, Systems of Systems, and Privacy Concerns

The literature on the uses of information technology for crisis or emergency management and response sheds light on how information and communication technology is increasingly supporting the collection and processing of citizen-generated content.

Calderon, Hinds, and Johnson [6] explained how human agents and non-human agents (autonomous systems) are increasingly being used to respond to large-scale disasters such as earthquakes or hurricanes, as well as in the decision-making process. They focused their attention on the difficulty of providing the right information – whether provided by humans, non-humans, or both – to the right agent. This difficulty is present whether the agent is a human, a drone, or an autonomous virtual agent, and the information must be provided at the right time in complex situations (i.e., such as those observed during emergency responses during large-scale disasters).

In order to address this question, public safety communities and public service agencies are more and more likely to use more and more ubiquitous and pervasive system of systems, in order to prevent and manage situations of crisis or emergency. A system of systems exists “when a group of independently operating systems – comprised of people, technology and organizations – are connected, enabling emergency responders to effectively support day-to-day operations, planned events, or major incidents” [7,

p. 12]. Büscher, Bylund, Sanches, Ramirez, and Wood [8] specified that systems of systems present characteristics such as autonomy, connectivity, diversity, and emergence. These systems also require interoperation at the mechanistic, system construction, and program-management levels [9]. They allow emergency responders to develop new, more efficient forms of communication, coordination, and collaboration [10]. New forms of interoperability can enable a more “agile response,” that is, a more richly and dynamically informed collaboration.

Putting the attention on the ethical challenges arising around information-technology supported interoperability in multi-agency emergency management (i.e., a system of systems), Büscher et al. [8] underlined the ethical opportunities of emergency management information systems (EMIS), such as their “capability...to extend surge capacity, to maximize availability and enable more equitable distribution of services, and to enhance risk communication” [8, p. 427]. However, emergency management information systems can also constitute a barrier to the adherence to core ethical principles, such as beneficence, respect for human dignity, and distributive justice.

Interoperability, combined with systems of systems and big data (i.e., large collections of data that require specific approaches to be managed) processing, can foster the development of a technological and bureaucratic apparatus for all-encompassing surveillance, and can erode civil liberties [8, 10-12]. The SMART search engine is an FP7 Project aimed at designing and implementing search services over large-scale environments and participatory sensing infrastructures. Regarding this search engine, Tarquini, and Morgano [10] argued that its data collecting and processing potential from participatory sensing makes fuzzy boundaries between decision support and control or surveillance. For instance, a knowledge database created through such a system could contain pervasive information revealing individuals’ habits, routines, or decisions, and consequently constitute a privacy infringement.

Scrutinizing the uses of drones for surveillance in civil applications, Finn and Wright [13] enlightened how these uses impacted upon privacy and other civil liberties. Indeed, drones combine the surveillance capabilities of both fixed CCTV cameras and helicopters. Consequently, despite policy-makers and law enforcement agencies mitigating concerns about privacy, the authors consider that the uses of such drones need to be regulated. Other authors [10, 14] have also shed light on the need for regulation when using information technology in crisis or emergency situations, in order to clarify misunderstandings about situations or cases (i.e., whether it is possible to collect, process, and share data with other stakeholders), and to foster good practices. As an illustration, Büscher et al. [10] explained how, during the 2005 London 7/7 bombings, a failure to share data, legitimacy, and silo-thinking led to inefficiencies and mistakes from part of the emergency agency, due to the misinterpretation of the requirements of the Data Protection Act of 1998 [10, p. 403]:

...in some parts of the emergency response...data controllers considered that it was not legal to pass personal data initially collected from victims by the Family Assistance Centre on to successor organizations for follow-up support. This complicated continuity of care for people at a very sensitive time.

Büscher et al. [8] argued for designing and implementing “in practice” emergency management information systems, enabling decision makers to balance individual rights to privacy with the need for information.

2.2 Social-Justice Issues When Using IT for Crisis Communication and Response

Different papers have worried about how using information technology for managing, responding to, and communicating during a crisis raises social-justice issues due to the risk of leaving behind non-equipped or special-needs citizens. According to Easton [15], inclusive design is often overlooked in emergency system’s development, leading to increased marginalization of certain societal groups, such as older or disabled persons. Technological developments lead to more agile response, but it is fundamental that new opportunities and benefits coming from such technological advances are equally given to all citizens. More specifically, equality of provision in relationship to emergency response and of participation has to be ensured. Through the concept of the “digital divide,” Easton [15] warned about the risks of exclusion of already marginalized populations from the data spread at the time of the crisis, and from the decision-making process due to unbalanced information collected from across the Internet, sensors, and information systems.

Stephens and Ford [16] were also concerned by such issues. Looking at how mobile devices are used for crisis management, they addressed digital inequalities in the workplace and their implications in organizational crisis communication. They explained how the digital divide can be due to structural implementations, not social determinants. The way workplace policies banishes mobile devices affects the way employees receive urgent information. The authors shed light on what they named “information holes” among:

1. Employees of workplaces the policies of which authorize them to keep their mobile devices during working hours, and employees of workplaces the policies of which do not;
2. Supervisors that are allowed to use mobile devices and required to be accessible at any time, and disadvantaged non-managerial workers that are non-authorized, or feel like being non-authorized, for using mobile devices at work.

Their study introduced a complex view of digital inequalities and organizational justice. It raised important questions about the way different types of workers can be reached in case of crisis or emergency situation.

Watson and Finn [17] discussed privacy and ethical implications surrounding the use of social media use during the 2010 Eyjafjallajökull volcano eruptions. Focusing on the crisis caused by the ash plume, they argued that even if social media tools provided a useful way to solve problems, passengers on the other side of the digital divide (travelers in a foreign country that may not have access to the Internet or mobile-phone services) may have been left behind. By focusing on social-media communication, crisis-management responders could have been led to mainly take care of the electronically equipped passengers, and consequently, to have additionally damaged the less-fortunate passengers not equipped or not able to use such technology, and thus unable to find the relevant online information.

2.3 Drones in Crisis Management and Humanitarian Aid: Safety and Liability Concerns

According to Finn and Wright [13], safety is a primary consideration for individuals when it comes to addressing the large-scale deployments of drones.

The Societal Impact Report (2012) of the FP7 program PACT underlined the opportunities offered by drones in crisis management and humanitarian aid. However, it also highlighted possibilities and concerns about crashes, collisions, and loss of communication between the device and the ground station for drones. The OCHA 2014 Report on Unmanned Aerial Vehicles (UAV) in Humanitarian Response (p. 9) also raised safety and liability concerns:

The main concern of regulators is safety and liability. Even high-end military models like the Predator crash with some frequency, although injuries are rare. In urban environments, however, even a smaller UAV could cause injury or property damage.

2.4 Responsible Research and Innovation, “Ethics-by-Design” and “Design in Practice” Approaches When Using Information-Technology-Supported Crisis Management and Response

Von Schomberg [18] argued that classical ethical theory and conventional ethical practice do not address both aspects of unintentional consequences and collective decisions that should be taken into account while

considering the issues of ethical responsibility in scientific and technological developments. He proposed an ethic of co-responsibility that should arise from reflections on the social processes in which technological decision making is embedded. Indeed, the “co-evolution” or “co-construction” of technology and society [19, 20] requires thinking about how information technology is designed and implemented, i.e., used in a specific context, such as crisis or emergency management and response. According to C. Rizza et al. [21], initiatives such as “privacy-by-design” or “ethics-by-design” [22, p. 12] attempt to deal with the current critique of technology’s contempt of ethical, legal, and social concerns. For instance, “privacy-by-design” heightens sensitivity to privacy issues during design, and can enforce compliance with privacy regulations when designing technology [23].

In the context of information-technology-supported crisis management or response, Büscher et al. [10] explored practices focused on “privacy-by-design” to implement “privacy sensitive agile emergency response,” without breaking fundamental freedoms. Specifically, they considered that privacy-by-design should be supplemented with methods supporting translation into the design and appropriation technologies. In the contextual, practiced nature of “privacy boundary management,” designers need to understand and anticipate how technology might be effectively used on the ground. Büscher et al. [8] proposed to create socio-technical systems supporting ethical conduct through a “design for an ethics of emergence,” suggesting “a human practice focused approach” when designing emergency-management information systems, in view of ethical and legal challenges.

Nathan, Klasnja, and Friedman [24] proposed a method supporting critical, systemic, long-term thinking in current design practice, technology design, and implementation. They framed their work in the “technological appropriation” approach. They considered that a technology is designed in, from, and content for determined uses and purposes, and is also shaped by individuals and society at large. Consequently, it can be appropriated in multiple ways. To help in anticipating how actions taken today will shape future conditions, they introduced the concept of value-scenarios, drawn upon five key elements: stakeholders, pervasiveness, time, systemic effects, and value implications. They argued that a careful consideration of diverse ranges of consequences, both positive and negative, is the key component of a design process.

3. The Capabilities of Drones in Crisis Management and Response

When a disaster occurs, rescue operations have to be quickly and efficiently organized to help populations, reduce the number of victims, and mitigate economic consequences. An inefficient organization generates additional damages, as well as delays the recovery phase. Facing uncertainty is closely related to issues of reliability, performance

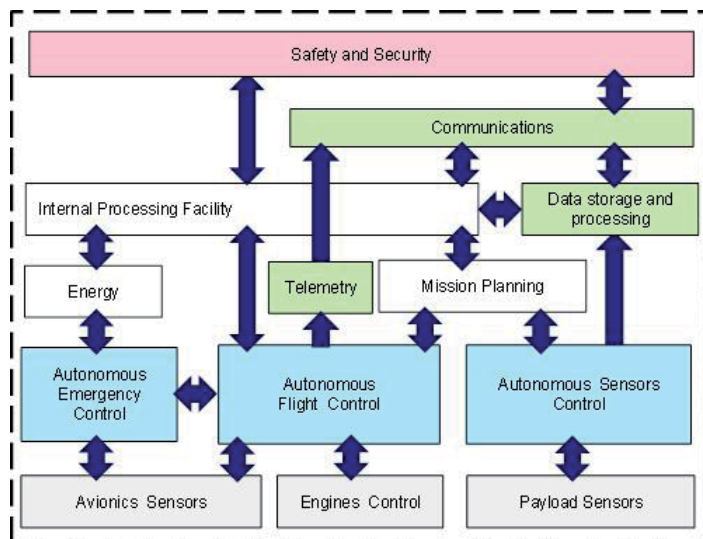

Figure 1. An example of a standalone architecture.

quantification, deception, attention focus, and effective translation of reported observations/inferences. When engaging a response, crisis managers are never totally aware of the current situation, which is a very unstable situation, by definition. Setting trust – defined as “the expectation of a reliable or good outcome despite vulnerabilities and imperfect knowledge” [25, p. 771] – combined with a data-control process would allow overcoming this data-quality issue. At any time, rescue teams need relevant information from the terrain in order to assess and monitor situations they have to face.

3.1 Designing Autonomous Crawling Equipment

Designing drones to support rescuers is a significant challenge [26]. Among high-technology objects of our modern environment, drones have potentials in supporting and extending the capabilities of rescue teams.

Tanzi and Isnard [3] defined the required advanced capacities (e.g., energy and decision-making) to design and implement autonomous drones for rescue missions. In collaboration with humanitarian organizations (i.e., French “Protection Civile,” MSF, ICRC), they defined the following scenarios, framing the capabilities of drones in crisis management and response:

1. The automatic coverage of a geographical area, including a devastated area;
2. The identification of groups of victims and their classification (e.g., adults/children); and
3. The automated search for buried victims (in rubble, for instance), or lost persons in difficult areas (such as forests), based on the electromagnetic radiation of the victims’ personal items (e.g., smartphones).

We consider that the flight capabilities of light drones, combined with non-conventional sensors (such as LIDARs and IR cameras), will significantly extend rescue-team response capabilities in the detection of victims, ground mapping, damage estimation, etc. We are currently working on a new architecture that combines specific hardware and software features to optimally benefit from the potential of light drones (see Figure 1).

This new architecture is based on autonomy properties supporting and managing the drone’s mission objectives. Indeed, we believe that using drones would not be efficient if specific competences were required from emergency units. Autonomy is then a *sine qua non* condition of such success. For instance, drones have to be able to monitor their own battery according to the situation (i.e., mission duration), while assuring the proper functioning of command and control systems (i.e., decision-making autonomy with regard to the mission objectives). Reflexive reactions, developed in an emergency process layer, should guarantee flight security. These mechanisms have to be protected from accidental or malevolent interference. An additional layer supports the adaptation of the mission planning and allows real-time reassignment.

In the following, we briefly present how drones constitute an asset for coordination centers and rescue teams by embedding specific sensors.

3.1.1 The Added Value of “Autonomous” Drones

Autonomous drones can be used to quickly detect victims and to acquire information when a crisis occurs, given the hypothesis that connected devices are nowadays mainly attached to a person rather than a place, as in the past. Indeed, detecting such devices may be easier and faster than other methods, thus allowing the drawing of priorities. Specifically, we present two related aspects of

an innovative solution to enhance rescue operations that is still in a development stage: using autonomous devices such as drones to crawl the area where a disaster occurred to gather information, and to thus assist ground teams.

In this context, we would like to prove that crawling device autonomy is a requirement, as well as a desirable feature.

Indeed, it is firstly a necessity, because there are very few rescuers in comparison to the number of victims. The rescuers therefore have to be preserved as far as possible from tasks that divert them from their duty, including managing a drone, which would moreover require skills such as informatics, electronics, mechanics, etc.

Secondly, this is also a matter of efficiency: human decisions are of course at the center of the reaction during a crisis. In many cases, the machine cannot make the decision by itself. However, it can facilitate the process, by offering objective information about the current situation. Indeed, under certain circumstances, this process can be altered: tiredness, stress, or even because of natural factors such as night, rain, mud, or excessive heat. In such conditions, autonomous drones can relieve rescuers in two ways. On the one hand, they can go to places that are difficult to reach, including unstable terrain, such as rubble. On the other hand, they can embed modern sensors, such as ground-penetrating radar (GPR), which can enhance the perception of the situation. Ground-penetrating radar is able to detect the slight movement of a body breathing under the remains of a building. Autonomy is therefore needed for efficiency, because it allows scanning a large area in a limited amount of time, without altering rescuers' activities.

4. Drones in Crisis Management and Response Activities

We structure our analysis according to the following crisis-management and response activities (see Figure 2):

- Communication and coordination
- Site/ground investigation
- Search and rescue operations
- (Autonomous) victim detection

For each item, we emphasize the role of autonomy in the response.

4.1 Communication and Coordination

In disaster management, the first stage for stakeholders is to establish a coordination center for operations. Communication, between stakeholders and with victims, is

crucial. Even if communication infrastructures have been damaged, communication has to be supported, and most of the time, rescue teams use radios and satellites. In this context, we consider that drones can extend communication capacities, since they can be deployed as mobile radios relays. They can also transmit messages in “disruption-tolerant network” (DTN) mode.

We are aware that drones generate their own requirements, such as a dedicated control center supported by the mobile units on the ground. Autonomous “behavior” of the systems, implemented to manage and respond to the crisis, supports operation and response transparency. Collected data has to be transmitted to manage rescue teams and engage response. In this context, we consider that drones should be autonomous when deciding whether communicating raw data or processing data before communication is better, in order to prioritize operations.

Last but not least, communications between the control center and the drone have to be secured to avoid any interference (from vandals, for instance), to prevent third-party unauthorized access to sensitive data, and to possibly detect communication abnormalities such as a drone crash, radio interference, etc.

4.2 Site/Ground Investigation

The identification and follow-up of a disaster's impact are mainly conducted through spatial and airborne means, based on radio and optical techniques. Due to optical limitations (i.e., night or a cloudy environment), radio investigations (e.g., microwave-based) – which are available 24 out of 24 hours and seven out of seven days, without any atmospheric limitations – are more likely to be used. They are specifically useful during the response stage of the disaster-management cycle, i.e., when information has to be collected and delivered as soon as possible to the crisis-management center [27-29].

Drones can significantly improve the data-collection process. They can be easily equipped with different types of optical or radio sensors, according to the mission. Their flight altitude enables data collection in a cloudy environment. Relief teams can bring and use drones according to the needs on the ground, e.g., to explore flooded areas or the ruins of buildings, in order to find and then reach potential victims. From our point of view, drones extend the range of investigation means of relief teams, and improve their security in specific risky or dangerous areas. For instance, following the 2010 Haiti earthquake, the SenseFly drone demonstrated the capacities of drones in automated mapping and in victim detection, by allowing authorities to quickly map devastated areas [30].

The design and integration of autonomy are fundamental for these applications. Indeed, a drone can face situations where communication with the management

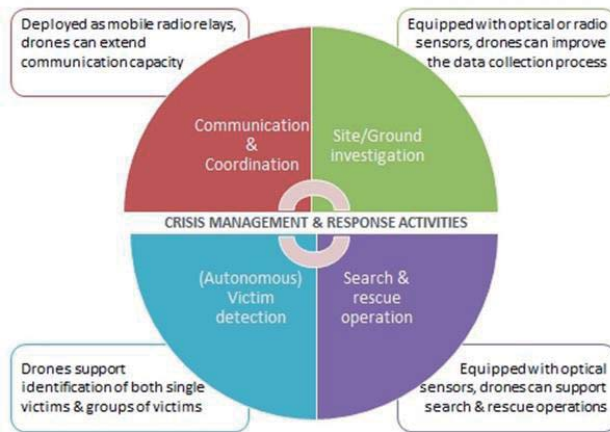

Figure 2. Drones in the crisis-management and response activities.

center is impossible or limited, due to interference or obstacles on the ground, or when a radio relay is not available. Following both communication capabilities and the complexity of sensors, collected data has to be processed by the built-in system, or sent to the control center in order to be processed, interpreted, and used by operational units. In any case, autonomy is essential when drones are used by “non-experts,” even if autonomy does not mean no remote control.

Again, at this stage, access to collected and stored data (i.e., communication during flight and in case of an accident) has to be secured. Furthermore, these data cannot be sensible with regards to victims’ privacy, and rescue systems cannot be used by a third party and cannot hinder rescue operations [31].

4.3 Search and Rescue Operation

As for ground investigations, satellites and planes are often used to localize and count victims. Questions related to passive systems, atmospheric conditions, and the availability of systems remain significant.

Autonomy is crucial in this phase. An appropriate range of sensors has to be combined to identify humans from inanimate objects, especially when victims are buried under rubble and cannot be optically detected. Drones should also be able to distinguish victims from rescuers. Finally, algorithms have to be adapted to the detection and monitoring of victims or groups of victims, in order to anticipate their movements and to potentially determine the support they may require.

Low-altitude and navigation autonomy can be a threat, as victims or rescuers may be injured in case of a crash, for instance. Consequently, such systems have to take into consideration this risk from the design phase. Security mechanisms must be integrated to prevent and manage any potential malfunctions of material or software. For instance, operating a drone in degraded mode is possible with less

engine power in order to land safely or, if not possible, to raise a parachute to reduce the impact consequences when returning to the ground.

The implementation of drones for these types of applications also sheds light on societal challenges. For instance, in a war context, the apparition of a drone can be horrifying for a non-prepared victim (i.e., Predator Syndrome), and can consequently reduce the rescue-operation effectiveness. Non-prepared victims also may not notice a drone and not identify themselves, while they would identify themselves in the case of a traditional aircraft (i.e., a helicopter or plane). New methodologies and norms have to be defined to support practices.

4.4 Autonomous Victim Detection

The identification of the affected population constitutes an important issue when engaging rescue operations. Two levels of identification—with objectives that are clearly different—need to be reached: identification of individual victims, and identification of groups of victims.

In the case of the identification of single victims, the objective is to determine their specific localization, and to follow them. It is important to first determine whether this person has already been identified or not (in order not to identify the same person n times). Classification information of individuals has to be constituted in terms of position and time-stamping. Thanks to this information, and according to the crisis context, it will be then possible to detect and classify a movement as normal or suspicious (e.g., wrong direction, too-low speed, etc.), and to prioritize the operations of rescue teams.

As far as the identification of groups of victims is concerned, the difficulty is to assess the density of the group, its general movement, and the evolution of the number of constitutive persons. To do so, it is possible to use work on the identification of a persons’ size and the colors of the persons’ clothes when establishing a visual signature

allowing the following of a group. These image-processing techniques are quite well known and come from the CCTV domain: the histogram of oriented gradients constitutes the usual detection algorithm, while the bounding-box and the color-image-histogram algorithms can be used to achieve persons tracking. These algorithms are useful in CCTV field, but they have not been assessed yet for an embedded solution.

Autonomous drones present capabilities in supporting crisis management and rescue operations. One can indeed make use of them to quickly detect the former and acquire information when a crisis occurs, given the hypothesis that connected devices are nowadays mainly attached to a person rather than a place, as in the past. Specifically, we have presented two related aspects of an innovative solution to enhance rescue operations that is still in a development stage: using autonomous devices such as drones to crawl the area where a disaster occurred to gather information and such assist ground teams. In the following section we discuss these aspects based on the social concerns presented above in the literature review. Our aim is to draft recommendations allowing us, in the next stages of our project, to design and implement drones for information-technology crisis management and response, taking into account potential ethical, legal, and social concerns “in practice.”

5. Conclusion

In “ELSI in crisis, do IT more carefully,” Büscher, Lieg, Rizza, and Watson [32] demonstrated how research around the ethical, legal, and social aspects of information technology for crisis management and response not only highlights challenges, but reveals opportunities. They recognized that [32]

Emergency situations call for exceptions, including exceptions to fundamental and constitutional rights and suspension of normal moral rules and values, often fuelled (but not always warranted) by fear of public moral disorder. Such exceptions can erode important civil liberties, and “the wrong kind” of information technology innovation in crisis management can amplify a more pervasive “securitization” of society.

They proposed to integrate information technology “more closely” into crisis response and management, with an explicit engagement with ethical, legal, and social considerations in order to provide useful insights for a more informed and proactive approach to innovation.

The Labsoc research group working on drones for humanitarian purposes made two strong hypotheses when designing their build-in systems:

- There is a strong link between a victim and a communicating object (e.g., a mobile phone) he/she owns. Consequently, the detection of electromagnetic

waves emitted by these objects will make it possible to locate victims and guide rescue teams;

- Drones will not be able to fully reach their support objectives if they require rescuers’ specific competences. Consequently, autonomy constitutes *a sine qua non* condition of such success.

The state of the art stressed three main concerns: data protection and privacy concerns; equality and social justice issues; safety, liability, and responsibility issues. Our design scenario clearly confirms these issues.

Our research project also allows us to identify other ethical, legal, and social issues. These include the risk of human-dignity infringement, and the potential impact upon civil liberties due to the pervasiveness of our systems (and algorithms).

Our design approach requires both technological and social research work. This is because, as we discussed before, even if we aim to design systems to save lives, as suggested by the state of the art, exceptions can lead to the erosion of civil rights. In order to design our system more “more closely” into crisis response and management with an explicit engagement with ethical, legal, and social considerations, our forthcoming research on this particular topic gathers scientists from both domains. Interactions of course take place during development as far as how features are implemented, but they play a major role when terrain tests take place, because this is the main way to validate our original hypotheses, formulated at the very beginning of the project.

As recognized before by Büscher et al. [8], we would like to supplement our “ethics-by-design” approach by translating this design into a technology appropriation process. Indeed, simulating the action of the system in near-real conditions allows to involve real actors, such as stakeholders, risk and rescue teams, and, of course, citizens. In order to achieve those tests, we are currently working closely with institutions, organizations, companies, and associations such as the French Civil Protection. Understanding and anticipating how our system might be effectively used will then allow us to design a socio-technical design supporting ethical, legal, and social conduct.

The next step may thus consist of performing real system tests in areas where disasters such as tsunamis, typhoons, or earthquakes can occur, especially if usual modern communication means (e.g., cell phone or broadband Internet access) are rare or not available in such areas (such as a small island). In addition to evaluating the system efficiency, this would allow people to get used to seeing drones, so that the day a crisis happens, they would be not surprised by those flying robots, avoiding the “Predator Syndrome.”

6. References

1. Commission Staff Working Document 2012 – “Towards a European strategy for the Development of Civil Applications of Remotely Piloted Aircraft Systems (RPAS),” European Commission, 18.
2. European Commission, “A New Era for Aviation: Opening the Aviation Market to the Civil Use of Remotely Piloted Aircraft Systems in a Safe and Sustainable Manner,” Brussels, COM (2014) 207 final.
3. T. J. Tanzi and J. Isnard, “Robot d’intervention multifonction d’assistance post-catastrophe. Réflexions sur un drone « humanitaire »,” *Revue de l’Electricité et de l’Electronique*, **3**, 2014, pp. 57-64.
4. T. J. Tanzi and F. Lefevre, “Radio Sciences and Disaster Management,” *C.R. Physique*, **11**, 2010, pp. 114-224.
5. US Department of Homeland Security, “The System of Systems Approach for Interoperable Communications,” 2004, available at <http://1.usa.gov/Y7JYFO> [20/11/2014].
6. A. C. Calderon, J. Hinds, and P. Johnson, “IntCris: A Tool for Enhanced Communication and Collective Decision-Making During Crises,” in S. R. Hiltz, M. S. Pfaff, L. Plotnick, and P. C. Shih (eds.), *Proceedings of the 11th International ISCRAM Conference*, University Park, Pennsylvania, USA, May 2014, pp. 200-209.
7. T. J. Tanzi and P. Perrot, *Télécoms pour l’ingénierie du risque*, Hermès ed., Paris, Collection Technique et Scientifique des Télécoms, 2009 (in French).
8. M. Büscher, M. Bylund, P. Sanches, L. Ramirez, and L. Wood, “A New Manhattan Project? Interoperability and Ethics in Emergency Response Systems of Systems,” 10th International ISCRAM Conference, Baden-Baden, Germany, May 2013, pp. 426-431.
9. E. Morris, L. Levine, C. Meyers, P. Place, and D. Plakosh, “System of Systems Interoperability (SOSI): Final Report,” available at <http://www.dtic.mil/dtic/tr/fulltext/u2/a455619.pdf> [20/11/2014].
10. M. Büscher, L. Wood, and S. Y. Perng, “Privacy, Security, Liberty: Informing the Design of EMIS,” 10th International ISCRAM Conference, Baden-Baden, Germany, May 2013, pp. 401-410.
11. D. Lyon, “Facing the Future: Seeking Ethics for Everyday Surveillance,” *Ethics and Information Technology*, **3**, 2001, pp. 171-181.
12. M. Tarquini and M. Morgano, “Ethical Challenges of Participatory Sensing for Crisis Information Management,” 10th International ISCRAM Conference, Baden-Baden, Germany, May 2013, pp. 421-425.
13. R. Finn and D. Wright, “Unmanned Aircraft Systems: Surveillance, Ethics and Privacy in Civil Applications,” *Computer Law & Security Review*, **28**, 2012, pp. 184-194.
14. C. Reuter, O. Heger, and V. Pipek, “Combining Real and Virtual Volunteers through Social Media,” 10th International ISCRAM Conference, Baden-Baden, Germany, May 2013, pp. 780-790.
15. C. Easton, “The Digital Divide, Inclusion and Access for Disabled People in IT Supported Emergency Response Systems: A UK and EU-Based Analysis,” in S. R. Hiltz, M. S. Pfaff, L. Plotnick, and P. C. Shih (eds.), *Proceedings of the 11th International ISCRAM Conference*, University Park, Pennsylvania, USA, May 2014, pp. 280-283.
16. M. Stephens and M. Ford, “Banning Mobile Devices: Workplace Policies that Selectively Exclude Can Shape Crisis Communication,” in S. R. Hiltz, M. S. Pfaff, L. Plotnick, and P. C. Shih (eds.), *Proceedings of the 11th International ISCRAM Conference*, University Park, Pennsylvania, USA, May 2014, pp. 284-288.
17. H. Watson and R. Finn, “Privacy and Ethical Implications of the Use of Social Media During a Volcanic Eruption: Some Initial Thoughts,” 10th International ISCRAM Conference, Baden-Baden, Germany, May 2013, pp. 416-420.
18. R. von Schomberg, “A Vision of Responsible Research and Innovation,” in R. Owen et al. (eds.), *Responsible Innovation*, London, Wiley, 2013, pp. 51-74.
19. B. Latour, “Where Are the Missing Masses? The Sociology of a Few Mundane Artifacts,” in W. E. Bijker, and J. Law, (eds.), *Shaping Technology/Building Society: Studies in Sociotechnical Change*, MIT Press, 1992, pp. 225-258.
20. S. Jasanoff, *Science at the Bar: Law, Science, and Technology in America*, Cambridge, MA, Harvard University Press, 1995.
21. C. Rizza et al., “Interrogating Privacy in the Digital Society: Media Narratives After 2 Cases,” *International Journal of Information Ethics*, **16**, 2011, p. 6-17.
22. European Commission, *A Comprehensive Approach on Personal Data Protection in the European Union*, COM 2010. 609 final, Brussels, 2010. 4.11.
23. M. Langheinrich, “Privacy by Design – Principles of Privacy-Aware Ubiquitous Systems,” 3rd International Conference on Ubiquitous Computing, 2001, pp. 273-291.
24. L. P. Nathan, P. V. Klasnja, and B. Friedman, “Value Scenarios: A Technique for Envisioning Systemic Effects of New Technologies,” CHI 2007, April 28-May 3, 2007, San Jose, California, USA, pp. 2585-2590.
25. A. H. Tapia, K. A. Moore, and N. J. Johnson, “Beyond the Trustworthy Tweet: A Deeper Understanding of Microblogged Data Use by Disaster Response and Humanitarian Relief Organizations,” 10th International ISCRAM Conference, Baden-Baden, Germany, May 2013, pp. 770-778.
26. P. Marks, “Smart Software Uses Drones to Plot Disaster Relief,” *New Scientist*, November 2013.
27. F. Lefevre and T. J. Tanzi, International Union of Radio Science, International Council for Science (ICSU), Joint Board of Geospatial Information Societies (jBGIS), United Nations Office for Outer Space Affairs (OOSA), 2013

28. T. J. Tanzi and F. Lefeuvre, "The Contribution of Radio Sciences to Disaster Management," International Symposium on Geo-information for Disaster Management (Gi4DM 2011), Antalya, Turkey, 2011.
29. P. Wilkinson and D. Cole, "The Role of the Radio Sciences in the Disaster Management," *Radio Science Bulletin*, No. 335, 2010, pp. 45-51.
30. E. Ackerman, "Drone Adventures Uses UAVs to Help Make the World a Better Place," *IEEE Spectrum*, May 2013.
31. T.J. Tanzi, O. Sébastien, and F. Harivelo, "Towards a Collaborative Approach for Disaster Management Using Radio Science Technologies," *Radio Science Bulletin*, No. 348, 2014, pp. 25-36.
32. M. Büscher, M. Lieg, C. Rizza, and H. Watson, "Ethical, Legal and Social Issues of IT Supported Emergency Response," *IJISCRAM*, Hershey, PA, Information Resources Management Association, 2014.

Calibration Procedures for Global Precipitation-Measurement Ground-Validation Radars

V. Chandrasekar¹, Luca Baldin², Nitin Bharadwaj³, and Paul L. Smith⁴

¹Colorado State University
Fort Collins, CO, USA
E-mail: chandra@engr.colostate.edu

²Institute of Atmospheric Sciences and Climate
National Research Council, Rome, Italy
E-mail: l.baldini@isac.cnr.it

³Pacific Northwest National Laboratory
Richland, WA, USA
E-mail: Nitin.Bharadwaj@pnnl.gov

⁴South Dakota School of Mines and Technology
Rapid City, SD, USA
E-mail: paul.smith@sdsmt.edu

Abstract

The calibration of weather radars has a direct impact on the accuracy of measurements and is therefore critical for most applications. For this reason, calibration has been an active topic of study since the early days of radar meteorology, involving both the research and operational communities. More recently, the discussion on radar calibration has been enriched by new challenges. First, the operational use of dual-polarization radars has created a new set of demands for differential measurements. Second, the use of radars in a network has highlighted the importance of best practices and standards to assure that all the radars of the network provide meaningful and comparable measurements. Moreover, modern technology has provided many avenues for automating the calibration process, thereby minimizing errors.

This paper was developed from the 2013 Weather Radar Calibration Laboratory Workshop, held at the Colorado State University (CSU) CHILL radar facility, Colorado, and from guidelines for calibrating ground-validation radars of the NASA/ JAXA Global Precipitation Measurement (GPM) mission. This paper takes a fundamental look at the weather-radar calibration process. It aims to illustrate to a broad audience how a collection of consolidated techniques and modern technologies can be used for the purpose of calibrating radar, with special attention to dual-polarization

systems. Examples referred to real measurements at several radar facilities are shown.

1. Introduction

The concept of the calibration of a weather radar system covers multiple aspects. Fundamentally, a weather radar measures the backscattered echo from precipitation. It produces derived variables, such as the equivalent radar reflectivity factor (denoted by the symbol Z_e , or simply, Z , and expressed in units of mm^6m^{-3}); the mean and standard deviation of the Doppler velocity spectrum; and, for dual-polarization radars, the differential reflectivity (Z_{dr}), the differential propagation phase (Φ_{dp}) in degrees, the co-polar correlation coefficient (ρ_{hv}), and some additional variables depending on the type and configuration of the radar system. For such radars, system check procedures include co-polar and cross-polar measurements, and specific procedures for monitoring the differential reflectivity, differential phase, and co-polar correlation coefficient can be adopted. While the calibration of radar measurements such as reflectivity is important, the radar provides information on these quantities as a function of three-dimensional position in polar coordinates. Position calibration is therefore also very important in a weather-radar system. The positioning in a mechanically scanning radar system is accomplished through azimuth and elevation positioners, and the angle data are typically

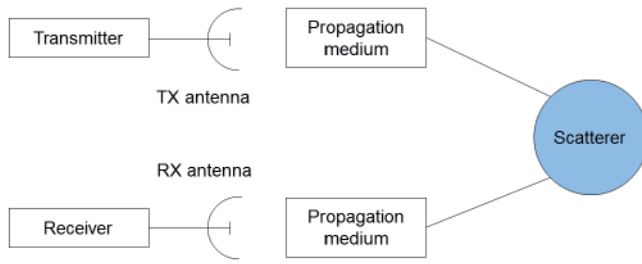

Figure 1. A thematic diagram of a weather radar. Separate antennas are shown here for transmitting and receiving, but in most radar systems, both functions share a common antenna.

derived from synchros or shaft-position encoders. The range to a radar echo is determined electronically from timing considerations, and timing measurements in radar are fairly accurate.

In this document, an introduction to radar as a system is first provided, to define the various aspects of calibration. Subsequently, system-check procedures are described from the perspective of “knowing the system behavior or characteristics.” To help understand radar as a system, it can be broadly divided into transmitter, receiver, and antenna subsystems, the propagation medium, and the scatterer(s) (Figure 1). To characterize the scattering object(s) within the illuminated volume, the transmitter, receiver, and antenna should be well characterized; in addition, we need to understand the behavior of the propagation medium. The transmitter determines the characteristics of the radiated signal (frequency, modulation, and amount of transmitted power), whereas the pointing of the antenna determines the direction of transmission, and the type of antenna determines the signal polarization.

Radar is a complex system consisting of many components, such as signal oscillators, receivers, amplifiers, filters, and microwave components. A typical radar system has too many components to make it feasible to characterize every component. For this reason, it is usually more useful to evaluate and characterize the system in terms of its major subsystems. Procedures to accomplish this task are illustrated in Section 2. For an overall verification of the radar calibration, it can be convenient to characterize the radar system as a whole. Section 3 describes and discusses some “end-to-end” radar calibration procedures. Radar calibration operations require expert personnel. Availability of “built-in” techniques can be effective for automatically monitoring some key elements contributing to the variation in radar calibration. Section 4 describes a couple of examples of built-in calibration techniques. Finally, Section 5 summarizes the calibration techniques and the instruments necessary to perform them. Recommendations for a calibration protocol are finally drafted.

2. Characterization of Radar Subsystems

The most important or commonly encountered calibration of weather radar is the calibration of the

equivalent reflectivity factor, or Z_e . To understand calibration to characterize the measurement of Z_e , it is useful to take a look at the weather-radar equation. In radar meteorology, it is conventional to express the volumetric radar cross section, η [m^2m^{-3}] in terms of the equivalent reflectivity factor as

$$Z_e = \frac{\lambda^4}{\pi^5 |K_w|^2} \eta, \quad (1)$$

where λ is the radar wavelength [m], and the dielectric factor, $|K_w|^2$, is computed for water. The received power at the radar at a chosen reference point (typically, at the output port of the antenna, the forward port of a directional coupler, or sometimes, at the input to the first amplifier or low-noise amplifier), can be expressed as

$$P_r(r) = \left(\frac{c\tau}{2}\right) \left[\frac{P_t G_0^2}{(4\pi)^3}\right] \left(\frac{\pi\theta_1\phi_1}{8\ln 2}\right) \left(\frac{\pi^5 |K_w|^2}{\lambda^2}\right) \frac{Z_e(r)}{r^2}, \quad (2)$$

where the various quantities are defined according to a standard weather-radar equation [1]. In particular, θ_1 and ϕ_1 [radians] are the antenna’s 3-dB beamwidth in azimuth and elevation, respectively; τ is the pulse duration [s]; P_t is the transmitted peak power; G_0 is the antenna gain; and c is the speed of light.

When the receiver sees power P_r at a time Δt seconds after the pulse transmission, the range, r , is therefore obtained as $r = c\Delta t/2$. The above equation is then used to compute the reflectivity, giving

$$Z_e = \left(\frac{2}{c\tau}\right) \left[\frac{(4\pi)^3}{P_t G_0^2}\right] \left(\frac{8\ln 2}{\pi\theta_1\phi_1}\right) \frac{\lambda^2}{\pi^5 |K_w|^2} r^2 P_r, \quad (3)$$

Based on this, the minimum-detectable reflectivity at a range r for unity signal-to-noise ratio (SNR) can be expressed as

$$\min(Z_e) = \frac{1}{\pi^5 |K_w|^2} \left(\frac{2}{c\tau}\right) \left[\frac{(4\pi)^3}{P_t G_0^2}\right] \left(\frac{8\ln 2}{\pi\theta_1\phi_1}\right) \lambda^2 r^2 (kTB_n), \quad (4)$$

In a general sense, the receiver and signal processor determine how weak a signal can be measured. The received

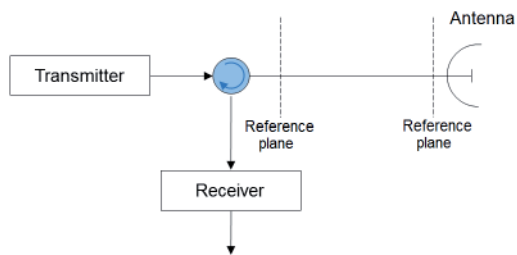

Figure 2. A thematic diagram of a weather radar for calibration purposes.

signals are processed through a filter, usually at intermediate frequency (IF), to enhance the signal-to-noise ratio, and that results in some signal loss.

Accounting for that, the IF power received from range r can be written as

$$\bar{P}_r(r_0) = \left(\frac{G_r}{l_r}\right) \left(\frac{c\tau}{2}\right) \left[\frac{P_t G_0^2}{(4\pi)^3}\right] \left[\frac{\pi\theta_l\theta_r}{8\ln 2}\right] \left[\frac{\pi^5 |K_w|^2}{\lambda^2}\right] \frac{Z_e(r)}{r^2}, \quad (5)$$

where G_r is the receiver gain, and l_r (> 1) represents the filter loss. Figure 2 shows the power measurements at the reference plane, which could be anywhere between the circulator and the antenna but is usually at a directional coupler nearer the circulator. It is important to establish such a common reference plane, not only for the measurements of transmitted power, but also for measurements of effective antenna system gain (Section 2.2.5) and for the receiver calibration (Section 2.3).

A radar is composed of three main subsystems: the transmitter, the antenna, and the receiver (or receiver and radar signal processor, or RSP). Each subsystem can in turn be decomposed into several discrete components. Consequently, a radar system has so many components that it is difficult to be able to characterize every component. For this reason, it is sometimes convenient to evaluate and characterize the radar system as a whole, as described in Section 3. However, to obtain diagnostic information, it is useful to consider the main subsystems and to individually characterize each single subsystem, or to consider combinations of two subsystems, such as the set of transmitter and antenna, and the set of antenna and receiver. For the sake of this characterization, many methods described in this section make use of external, or “known,” sources, such as the sun or an external transmitter (with a standard antenna), and a receiver that can allow one to characterize more than one subsystem.

The pyramidal standard-gain horn is useful in this work. This is composed of four conductive planes arranged to form a pyramid with a rectangular base, terminated with a flange for connecting it to a waveguide. The nominal gain is provided by the manufacturers as a function of wavelength and polarization. A standard-gain horn can be

procured or shared among organizations. It is used to analyze polarization states by rotating about its axis (orthogonal to the polarization plane), using precision rotary positioners. The horn should be placed in the far field of the antenna, and on an elevated platform in a relatively clear area, to avoid multipath reflections and beam blockage.

The sun is also a useful reference source, which can be used for several aspects of the radar-calibration process. Its usefulness also arises from the fact that it can be observed from most places on the Earth on a regular basis (except at very high latitudes, both North and South). It can be treated as an un-polarized standard noise source, the position of which at any time from a given location on Earth can be precisely predicted. The solar flux incident on the surface of the Earth is generally non-polarized, and varies from 100 to 300 solar flux units (an SFU is defined as $1 \times 10^{-22} \text{ WHz}^{-1} \text{ m}^{-2}$). Measurements are made available from several solar observatories, such as the Solar Environment Center or Dominion Radio Astrophysical Observatory at Penticton, BC, Canada, at 10.7 GHz. These can be scaled to other frequencies, such as C and X band. At 10 cm wavelength, the (microwave) sun is approximately 7% larger than the optical sun. One should be also aware that the ‘microwave center’ of the sun does not always lie at the center of the visible disk. The use of the sun to evaluate antenna pointing accuracy can thus encounter difficulties (except at very low latitudes, where east- and west-pointing measurements can be averaged). Most weather-radar manufacturers provide a utility, which will be henceforth referred to as a solar scan utility (SSU), that can automatically perform some calibration applications based on the sun. These include the determination of antenna pointing, and the estimation of two-dimensional solar observations that are referred as sun scans.

The following subsections describe the basic measurements that can be carried out during scheduled maintenance operations. Keeping track of measurements is of central importance, and regular sun scans go a long way in this aspect.

2.1 Transmitter Measurements

To estimate the equivalent radar reflectivity factor, Z_e , from received power using the radar equation, Equation (5), transmitting parameters such as the peak power, P_t , the transmitter wavelength, λ , and the pulse duration, τ are supposed to be known. However, other elements characterizing the transmitted signal that are not explicitly mentioned in the radar equation (such as the pulse shape) should also be characterized. These can be measured and monitored over time for diagnostic purposes, because they affect some parameters that explicitly appear in Equation (5) that describe the received power. The following subsections describe which are the relevant transmit parameters that may be monitored, and some methodologies to measure their performance.

2.1.2 Transmitted Wavelength

The parameter λ , appearing in Equation (5), is normally determined by measuring the transmitting frequency, f , and using the conversion $\lambda = c/f$. Alternatively, this relationship can be used to rewrite Equation (5) in terms of f . Frequency measurements can be made with electronic frequency counters or spectrum analyzers (SA), or with tunable-cavity instruments. In systems with power-amplifier-type transmitters, such as klystrons or traveling-wave tubes, the frequency is usually established by a precision oscillator arrangement, and tends to be quite stable. For systems with magnetron transmitters, the transmitted frequency can fluctuate because of the influence of different environmental conditions, particularly as far as the operating temperature is concerned. To limit the influence of these fluctuations, the transmitter needs to work in stabilized environmental conditions. Automatic frequency control (AFC) systems that follow changes in the transmitter frequency to readjust the receiver can be helpful in detecting and compensating for variations within a narrow range. In the installation phase and during maintenance operations, investigations of the possible influence of operating temperature on transmitting frequency should be done using a spectrum analyzer.

2.1.3 Transmitted Pulse

Most meteorological radars operate with pulsed transmissions. The characteristics of the actual transmitted pulse have a major influence on system performance. Several characteristics of the transmitted pulse are explicitly included in Equation (5), or indirectly influence it. Power measuring (and other) instruments are limited in both the amount of average power and the amount of peak power that can be safely tolerated. Therefore, a directional coupler, and often, additional attenuators, are required to couple only a small fraction of the transmitter power, to provide a safe driving level to protect whatever test instrument (such as a power meter, spectrum analyzer, or detector) is used to measure the pulse's characteristics.

The peak transmitted power, P_t , and the pulse duration, τ , are explicitly used in Equation (5), and in principle, both must be determined. Many different terms are used when talking about power. Peak power is the maximum instantaneous power, although in applications such as Equation (5), what is implied is the average over one complete RF cycle at the peak of the pulse envelope. Average power is the power averaged over the complete waveform time of the radar. For a pulsed radar with an ideal rectangular pulse shape, this is the product of the peak power and the duty cycle (the ratio of the "on" time to the total pulse-repetition interval). Most typical RF and microwave power meters are average power meters, but

average-power data can readily be used in the calibration process. The product of the peak power, P_t , and the pulse duration, τ , is the pulse energy. The product of that with the pulse-repetition frequency, PRF , is the average power, P_{av} . It is the *product*, $P_t\tau$, that appears in equations such as Equation (5). One can therefore merely divide a measured value of P_{av} by the PRF to obtain the product value $P_t\tau$, without the need to separately determine the values of those parameters.

Using average power measurements is therefore a common method for characterizing the power of a radar waveform that is fairly simple to perform. Within the "weather radar equation," the factors peak power and pulse duration appear as a product, and knowing the average power is therefore sufficient. This approach has the added advantage that if the pulse envelope is not perfectly rectangular (as is usually the case), the measurement of pulse energy is still correct, while difficulties in separately determining P_t and τ may lead to errors in the calibration. This implies that "simple monitoring" of average transmitted power measurements in the calibration is very effective. This concept will be further discussed in Section 4, for application to automatic calibration techniques.

Routine measurements of transmitter power are sometimes done in terms of peak power, with peak-reading RF power meters. However, in the case of irregularities in or changes to the waveforms, or in the presence of the magnetron frequency drifts, the ratio between peak and average power (i.e., the duty cycle) may vary, as well. Referring to the considerations above, the practice of measuring the average transmitted power value that can be routinely implemented is recommended as a good diagnostic tool.

The pulse duration, τ , that appears in Equation (5) would be easy to determine if the pulse envelope were perfectly rectangular, but it is otherwise not related in any simple way to the pulse shape. Using a digital oscilloscope and detector, one can observe and record the shape of the pulse envelope in time. For such a case, the pulse duration is usually defined as the width of the pulse at the instant when the signal is either one-half or (better) 70.7% of the signal's maximum amplitude. However, the product of this estimate of τ and the measurement of peak power, P_t , may or may not provide a good approximation of the pulse's energy. A sample of the transmitted signal can be analyzed through a spectrum analyzer, provided that a calibrated coupler and attenuators as necessary to reduce the signal level into the spectrum analyzer are used. The spectrum analyzer's output indicates the center frequency of the transmitted signal, and the frequency and level of sidelobes in the spectrum. To estimate the actual pulse-repetition frequencies, measurements performed with a basic oscilloscope are sufficient.

2.1.4 Transmitter Measurements Summary

It is convenient to use a specific form that summarizes the measurements of the transmitter subsystem power over a calibration exercise. Records should report the date, the instrument used for the measurement, and the average/peak power values (for both channels in a polarimetric or dual-wavelength system). The use of the same instruments that are routinely sent to calibration labs is strongly recommended. The record of when the test instruments are sent for calibration is a good practice.

2.2 Antenna Measurements

Antenna performance is critical to every radar system. This section deals with calibration of the antenna's performance, including measurement procedures for the characterization of both the mechanical and the electromagnetic properties.

2.2.1 Antenna Pointing

Currently, most weather radars rely on mechanical drive systems to steer the beam. The accuracy in positioning the antenna will determine the accuracy with which the volume of the precipitation samples can be characterized. This is critical in applications where cross measurements from different radars (at different frequencies or in regions of overlapping) are performed. Accurate positioning of the radar antenna is necessary for properly geo-referencing radar measurements. Analysis of the antenna's pointing angles can be accomplished by combining different methodologies, which include the use of very precise angle-measurement devices, and specifically designed solar scans. These devices can include a classical gunner's quadrant (GQ), a precision clinometer, or a modern laser pointing device. The angle-measurement devices allow for checking the linearity of any positioning error, while the solar scans are intended to determine the relationship between the indicated azimuth or elevation angle and the true orientation of the beam's axis.

Modern radar processors typically provide a solar-scan utility (SSU) that allows for a periodic check of the antenna's pointing accuracy. In order to accomplish that, the typical solar-scan utility runs a sector scan across the sun, covering specified azimuth and elevation sectors centered on the "expected" position of the sun, with elevation step sizes that can be specified by a user. The sun cannot be considered a point target, and therefore the effects of its finite size must be taken into account by the solar-scan utility processing. Moreover, the size of the "microwave sun" differs from that at visible wavelengths, and is also slightly different between frequency bands (such as S to Ka band). If the solar-scan utility runs the scan in typical raster

mode, with alternating clockwise and counterclockwise traverses on successive elevation steps, any significant backlash in the azimuth data-system linkage will blur the solar image, and increase the uncertainty in comparing the antenna's pointing-angle data with the known sun position. Consequently, the azimuth backlash tests discussed later should be conducted prior to use of the solar-scan utility. The solar-scan utility then fits a two-dimensional paraboloid to a contour plot of the solar return signal, and provides a value of the peak solar "signal" intensity, along with estimates of the antenna-orientation errors in azimuth and elevation, as well as the beamwidths. The solar-scan utility requires minimum intervention of the operator, and can be run numerous times over the course of a calibration, or during routine radar operations in the absence of precipitation.

Although the solar scan can be done almost all days, the use of solar scans for antenna pointing purposes can be limited, depending on the radar frequency, the latitude of the radar, and the day when the solar-scan utility is run. For example, the antennas of high-frequency radars may be too small to collect a solar signal with sufficient signal-to-noise ratio (SNR). Moreover, microwave thermal emission from any intervening clouds can become a concern. Comparison of the sun's position to antenna-pointing solar-scan utility data can be compromised by atmospheric refraction effects that could be relevant at low elevation angles. The use of sectors where the sun is too low should therefore be avoided, because of potential refraction problems. Radars in tropical latitudes have the ability to observe the sun over a wide range of angles, in order to characterize positioning accuracy over a large range of elevation and azimuth angles. However, the data quality at azimuths around 0° or 180° may be poor, because the sun will be at high elevation angles, where it subtends a wide azimuth sector. At high latitudes, the range of elevation angles accessible in solar scans will be limited.

A difference may be observed between morning ("sun rising") and afternoon ("sun setting") pointing-error values. If the pedestal is truly level (this should be checked, as outlined in the next section), such a difference is probably related to some displacement of the "microwave center" of the sun from the center of the visible disk. The ephemeris data used by the solar-scan utility as a reference for determining any orientation errors are based on the location of that center. At latitudes near the equator, any such displacement would contribute error increments of roughly equal magnitude but opposite sign in data from eastward- and westward-looking directions. A comparison of the error data from morning and afternoon sun scans therefore highlights any center-displacement effect, and averaging the two would then indicate how to correct the orientation-angle values. Unfortunately, this capability degrades as one moves away from the equator, and careful attention to the status of solar activity and repetition of the scans over an interval of time become necessary.



Figure 3. A gunner's-quadrant measurement on a flat surface being made by one of the authors (PLS) at the CSU-CHILL radar facility.

2.2.2 Elevation

For elevation (EL) angle data, a combination of an angle-measurement device and solar scans can be used. In what follows, a gunner's quadrant (Figure 3) will be used for purposes of illustration, but any clinometer with a precision of the order of 0.01° could be used. The gunner's quadrant data provide accurate measurements of angle increments from some reference, such as the plumb position of the antenna reflector, and allow for characterizing any nonlinearity in the angle-data conversion device used by the radar. Such a nonlinearity can make it difficult to extend the absolute angle data calibration over the full range of angles. Solar scans can then provide absolute values of pointing angles, allowing for compensation for any boresight error in the antenna. The first step of elevating pointing verification is to assess the precision of the antenna pedestal's leveling. This can be accomplished using a gunner's quadrant mounted on the back of the antenna's support structure. A 360° -azimuth rotation of the antenna, with a fixed elevation, can show the peak-to-peak variation of the elevation angle measured

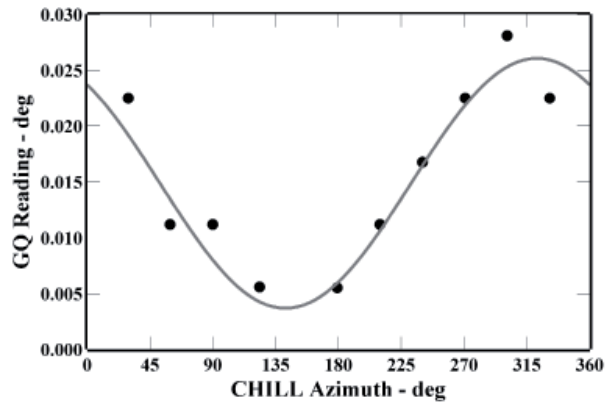

Figure 4. An example of a gunner's quadrant used for data checking the leveling of the CSU-CHILL antenna pedestal.

by the gunner's quadrant. For a well-leveled pedestal, this variation should be of the order of 0.04° or less. Figure 4 shows the results of leveling the CSU-CHILL radar using the method described above. The gunner's quadrant can be read to a precision of 0.005° , and the 0.01° amplitude of the fitted sinusoid indicated that the pedestal was level to within about 0.01° . (The data offset from zero here was of no consequence: the antenna structure does not need to be at zero elevation during the antenna's rotation in azimuth.) Once the leveling is assessed – and corrected, if necessary – the antenna can be moved, in a fixed azimuth, through a range of elevation angles.

Comparisons of elevation-angle increments (with respect to a reference, such as a plumb line) indicated in the radar signal-processor output with angle increments determined from the gunner's quadrant (used as true reference) can reveal any nonlinearities in the angle-data indications. These measurements should be performed with antenna movements in both the up and down directions. Any differences in measurements between the two directions reveal both anomalies in the angle data, or evidence of

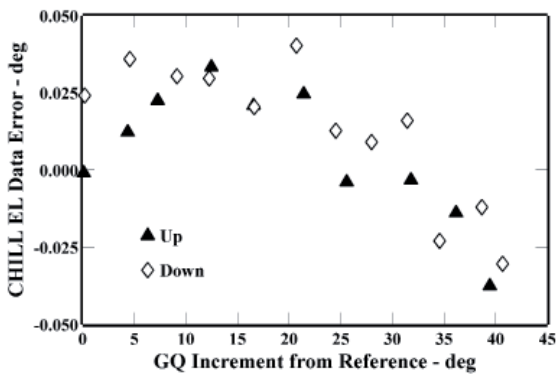

Figure 5. A plot of the errors in the indicated elevation-angle increment from an approximately plumb starting orientation as a function of the actual increments measured with a gunner's quadrant (CSU-CHILL radar).

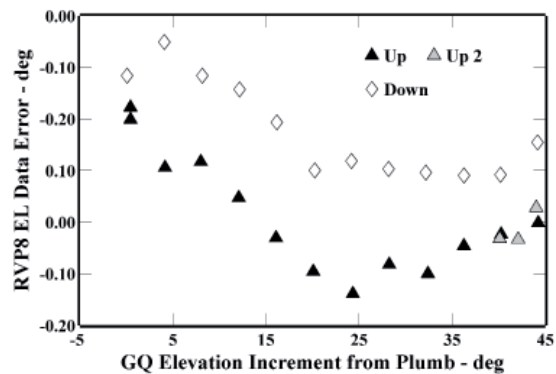

Figure 6. An example plot of the error in indicated elevation-angle increment (from a plumb antenna) as a function of the true angle increment measured with a gunner's quadrant. The points denoted by open triangles represented repeated measurements (NASA KPol radar, RMI).

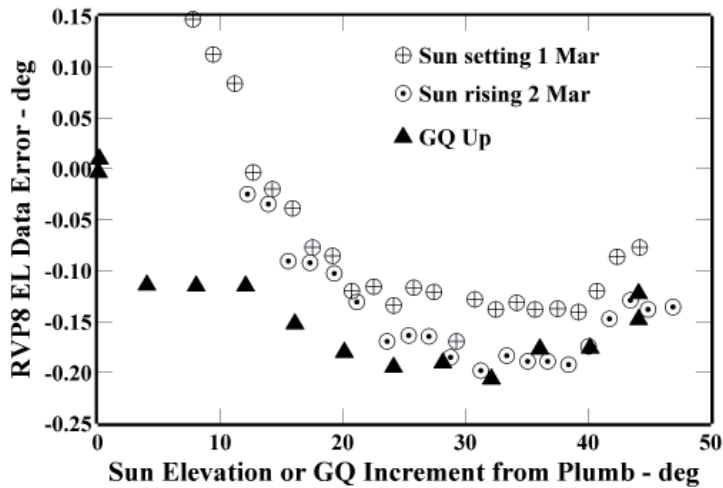

Figure 7. An example plot of solar-scan (absolute) and gunner's-quadrant (relative) elevation-error data, overlaid on a common plot. Only the gunner's-quadrant "upward" data were included here, because the solar-scan utility employed for the solar scans worked upward from below the sun (NASA KPol radar, RMI).

backlash. Figure 5 represents an example plot of the differences between elevation-angle increments (from an approximately plumb antenna) measured by the radar signal processor and the elevation-angle increments determined by the gunner's quadrant. The CSU-CHILL antenna uses digital shaft-position encoders. A slight nonlinearity, amounting to less than 0.1° over the full 45° range of the plot, was apparent. A comparison of the upward and downward data showed no evidence of any significant backlash. No easy access was available to establish a plumb orientation of the CSU-CHILL antenna, so the reference orientation was an indicated elevation angle of 0.01° .

Some antenna angle-data systems that derive the position data from synchros and employ a synchro-to-digital conversion process for further processing exhibit more-substantial nonlinearities. Figure 6 shows an example from measurements collected through the RVP8 radar processor of the NASA KPol S-band radar at Kwajalein Atoll (Republic of the Marshall Islands). Note that the range of the ordinate in this figure is three times that in Figure 5. Here, there was evidence of much greater nonlinearity, as well as significant backlash. The backlash problem was traced to a defective anti-backlash gear in the elevation-synchro linkage. Replacement of the gear reduced the indicated backlash to about the same order as the typical 0.03° uncertainty in the synchro data.

It is more difficult to deal with the nonlinearity problem, because no simple linear (additive) adjustment to the elevation data can correct the error at all elevation angles. When the antenna is plumb, the beam axis may not actually point to zero elevation, because of some boresight error in the antenna alignment. Checking the absolute accuracy of the elevation data thus requires an external reference. With the caveats discussed in Section 2.2.1, the sun usually provides the most suitable reference. Ephemeris data provide accurate sun-position information, and solar scans at elevation angles high enough to avoid ground-reflection and atmospheric-refraction problems provide the data needed to evaluate and, if necessary, adjust the radar-system elevation data. Solar-scan utility scans can

provide the necessary comparison data, but with a little practice, the data can also be acquired manually for suitably configured radar systems.

Figure 7 shows an example plot of nonlinear elevation-data errors determined from solar scans with a solar-scan utility (circles). The indicated nonlinearity over the plotted range was more than $1/3^\circ$, but as suggested below, the data below about a sun elevation of 12° to 15° were probably affected by atmospheric-refraction processes. No backlash information can be inferred here from a comparison of the sun-rising (eastward-looking) and sun-setting (westward-looking) data, because all the solar-scan utility scans started below the sun elevation, and scanned upward.

Plots such as Figure 5 and Figure 6 indicate that the errors in the elevation data cannot be reduced to zero at all elevation angles by a simple fixed additive adjustment. Fitting a curve (a sinusoid is the most likely function) to the data would provide a means for correcting the elevation data. In systems where only an additive adjustment (an "elevation offset" correction) is available, the best that can be done is to either center the errors around zero, or drive them to zero at some specified elevation angle. In weather-radar applications, the low-angle data are usually most important, while data from high elevation angles come from nearer the radar, and hence are subject to smaller errors in actual vertical distances.

A plausible approach is consequently to make an offset adjustment that yields near-zero errors at zero elevation, and to accept the fact that the angle errors will be greater at higher elevation angles. To do this, one can overlay solar-scans and gunner's-quadrant elevation-error data (triangles) on a common plot. The gunner's-quadrant-based relative errors are (essentially by definition) zero at the reference position (at or near zero elevation, usually plumb), and are independent of any additive adjustment to the elevation-data values. To make the solar-scan absolute errors also zero at the reference position, one merely adds an adjustment to the elevation data that moves the solar-scan data up or down the plot until they overlap the gunner's-quadrant data. The

plots may not be parallel over the full elevation range. If they are parallel only for high elevation angles, the likely explanation is the influence of atmospheric refraction effects that affect solar-scan utility outcomes at lower elevation angles. This behavior was evident in Figure 7 below about 15° elevation. To avoid this influence, it is necessary to work with data in the elevation range where the plots appear to be fairly parallel. The offset between the two sets of points can be assumed to be the needed elevation-data offset. Figure 7 was based on solar-scan data obtained after an initial adjustment to the elevation data; consideration of the portion of the plot above 15° elevation suggested that a further adjustment to move the solar-scan data points a few hundredths of a degree downward would be in order. In summary, the elevation-offset adjustment should make the solar-scan utility and gunner's-quadrant plots overlap. Any offset adjustment made to the elevation data should be rechecked with a new set of solar scans. Long experience with trying to decide the proper sense (positive or negative) of any adjustment to be made indicates that it is usually quicker to just choose one and check to verify both the sense and magnitude of the adjustment. Repeating the solar-scan measurements under different conditions could highlight the effect of changes in the refraction index on different days.

2.2.3 Azimuth Orientation

For the azimuth data, there is no independent reference device corresponding to the gunner's quadrant. Checking the azimuth orientation consequently cannot rely on the difference between data from such a device and the antenna's azimuth (AZ) data to estimate relative errors. Therefore, azimuth-data verification has to rely only on absolute-error data collected via the solar-scan utility. Other point-target observations (employing such things as balloon-borne spheres or corner reflectors) are sometimes used for this purpose. Solar observations can be hampered by the limited range of azimuth angles that can be satisfactorily examined with solar-scan utility scans. The solar-scan utility itself, or the operator, should limit the azimuth sector considered, avoiding the use of sectors where the sun is too low, because of potential atmospheric refraction problems (though such problems have lesser effect on the azimuth data). Sectors where the sun is so high that the distinction between azimuth and elevation angles becomes blurred should also be avoided, because it is difficult to get good angle-error values.

Nevertheless, if the azimuth-data system exhibits nonlinearity similar to that illustrated in solar data from a sector wide enough to permit it, fitting a sinusoid to a plot of the azimuth data error as a function of azimuth angle is desirable. For radar systems in which the gunner's-quadrant elevation-data check shows reasonable linearity and the azimuth data come from a similar transducer (e.g., a digital shaft encoder), it is reasonable to assume that a simple additive adjustment should suffice to correct any

errors in the azimuth data. For such systems, the azimuth-data errors indicated by solar scans should be essentially independent of the azimuth angle, unless the "microwave center" of the sun is displaced. In that case, the averaging of errors found for different azimuth directions may yield a reasonable estimate of any required offset to the azimuth data (especially at low latitudes). It is recommended to repeat solar-scan experiments in different periods of the year, with optimal azimuth sectors for performing the solar-scan utility. Such repeated measurements could show possible displacement of the "microwave center" of the sun from its geometric center.

2.2.4 Antenna Backlash Measurements

A further application of sun-position data that is not included in the usual solar-scan utility standard functions is the estimation of backlash in the elevation-data linkage, by simple recording of a slow range-height indicator (RHI) sector scan, centered on the sun's elevation. The azimuth is chosen so that the sun crosses the azimuth at which the range-height-indicator sector scan is run. Differences in the elevation-data error at maximum solar-noise power between ascending and descending scans can indicate any backlash. Similar estimations of backlash can be obtained with a standard-gain horn situated in the far field of the antenna, as for the antenna measurements discussed in Section 2.2.2. Azimuth traverses in both clockwise and counterclockwise directions, while receiving a signal radiated from the standard-gain horn, provide data to assess any backlash in the azimuth data chain (see Figure 8). This can also be done for elevation, by upward and downward range-height indicators, though the downward scans through low elevation angles require some care.

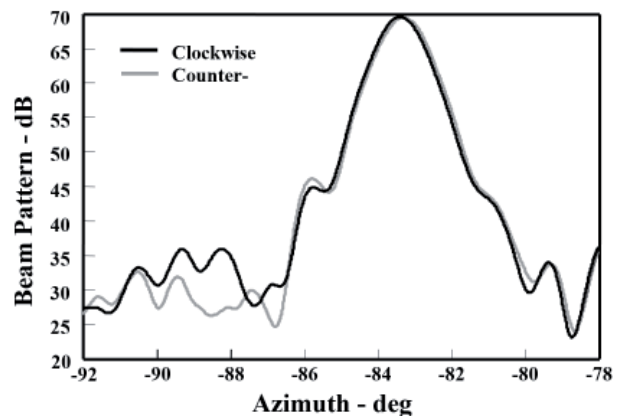

Figure 8. An example plot of data from clockwise and counterclockwise traverses, at a fixed elevation angle, across the location of a standard-gain horn in the far field, radiating a CW signal. The offset between the two curves indicated backlash of 0.09° in the azimuth data linkage (CSU-CHILL radar).

2.2.5 Antenna Beam-Pattern Measurements

The angular resolution of the antenna appears in Equation (5) as θ_l and φ_l , the half-power widths of the antenna's radiation pattern (i.e., the -3 dB beamwidth), which for a radar antenna at S, C, or X band is typically of the order of 1° . Antenna beam patterns are usually measured at the test range by the antenna manufacturer. The beam pattern and beamwidth should not change with time, unless there has been an incident with the antenna, such as mechanical shock, or fatigue. However, periodic field measurements of the antenna pattern can indicate some variations in the performance of the system. The antenna beam-pattern measurements can typically be performed on site by using:

1. An external device. In particular:
 - a. By transmitting the radar signal to a calibrated receiving antenna and microwave power meter located in the far field (at a distance greater than $2d/\lambda^2$, where d is the geometric diameter of the antenna), and elevated enough to make interference from ground reflections and multipath effects negligible;
 - b. By returning a signal from a source and calibrated antenna in a similar remote location to the radar receiver.
2. The solar-scan utility, assuming the sun is an external known radiation source.

Unless automatic means of simultaneously recording both antenna position and received-signal data are available, method 1.a is only practical for limited purposes, such as determining the antenna's 3 dB beamwidths. The second method has the obvious advantage of a simpler setup. However, the signal-to-noise ratio achievable using the sun is not sufficient to detect sidelobe levels. Using method 1.b, beam patterns are obtained by transmitting a CW signal from a distance sufficient to be in far-field conditions, and recording the signal received by the radar as the antenna scans across the location of the source. For this purpose, a microwave signal generator can be used with a standard-gain horn to radiate the signal.

Prior to making scans, the quality of the horn site should be validated by moving the horn slowly up and down, and noting any variation in the signal received at the radar. Such variations should ideally be no greater than 0.1 dB or 0.2 dB. To obtain data for constructing a full three-dimensional (3-D) beam pattern, scans should be performed with azimuth traverses at a series of elevation steps. To assure a proper over-sampling, the antenna azimuth scan rate (ω) for such a beam-pattern task should be no faster than given by the equation

$$\omega = \frac{\theta_l PRF}{20n_p}, \quad (6)$$

Here, n_p denotes the data sample size (i.e., the number of pulses). If the traverses alternate between clockwise and counterclockwise for successive elevation steps, data adjustment for any backlash in the azimuth data system linkage will be needed. Additional elevation scans in the vicinity of the location of the source can be performed at finer resolution to better define the elevation beamwidth.

For the H channel, three-dimensional antenna beam patterns can be obtained from scans made with the standard-gain horn radiating an H-polarized signal, or with a 45° polarized signal. The panel in Figure 9 (top) shows a color plot of the data (normalized to 0 dB on the beam axis) from such measurements collected with alignment of the beam axis with the standard-gain horn at about azimuth -83.5° . The first sidelobe level is about 26 dB down from the on-axis gain of the antenna. The middle panel shows a similar plot of the H-channel beam pattern derived from a similar raster scan with the horn radiating a 45° polarized signal (for the simultaneous transmit and receive – STAR – radar polarization scheme). The first sidelobe level there was indicated as about 25.2 dB down. A full three-dimensional antenna beam pattern for the V channel can be obtained from a similar scan with the standard-gain horn radiating

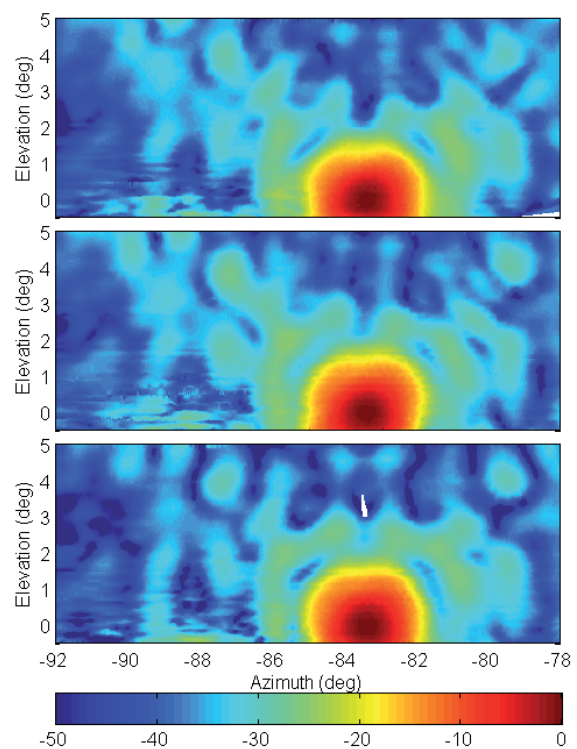

Figure 9. Color plots of the antenna beam patterns, obtained with the standard-gain horn radiating a test signal. The H-channel antenna beam pattern was obtained with the horn radiating an H-polarized (top) and a 45° polarized (middle) signal, and the corresponding plot of the V-channel antenna beam pattern was obtained with the standard-gain horn radiating a V-polarized signal (bottom) (NASA KPol radar, RMI).

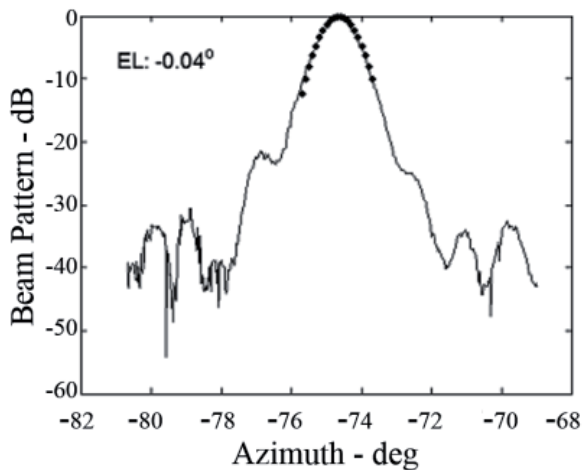

Figure 10. An example of data from an azimuth cut through the antenna-beam axis. With semi-log scales, the parameters of a parabola fit to the points near the axis determined the 3 dB beamwidth (CSU-CHILL).

a V-polarized signal, or from the same 45° signal scan if data from both channels are recorded (some data systems record only Z_h and Z_{dr} , with the range of the latter values inadequate to determine a full V-channel beam pattern.) The bottom panel in Figure 9 shows a color plot of the normalized data from a V-channel scan of the former type. The first sidelobe level here was about 26 dB down from the on-axis gain of the antenna.

Performing beam-pattern scans with the horn radiating a 45° polarized signal (or using H and V polarizations in the case of alternate-polarization radar), the polarimetric variables Z_{dr} , ρ_{hv} , and Φ_{dp} can be recorded (not shown). It should be stressed that what is determined in this way is the pattern resulting from the antenna-receiver subsystems, and the offset thus determined includes both the difference in the antenna’s receiving gain between the two channels, and also the difference in receiver sensitivities, and includes any “ Z_{dr} offset” in the data system. However, it takes no account of any differences in the transmitting side of the system. The absolute values therefore have no particular significance. However, the variations across the main lobe should be less than 0.1 dB to allow the weighting of differential reflectivity for scatterers across the main part of the beam to be reasonably uniform. Similar plots can be obtained for the other polarimetric variables.

Plotting the differential phase is mainly useful in indicating the inherent system differential phase. Moreover, the differential phase should also be fairly uniform across the main lobe, whereas a near-perfect correlation in the main part of the beam pattern would be expected for the co-polar correlation coefficient.

Data from principal-plane cuts through the beam axis permit determination of the antenna’s beamwidths. For example, data from a traverse through the location of the standard-gain horn used to obtain the beam-pattern data

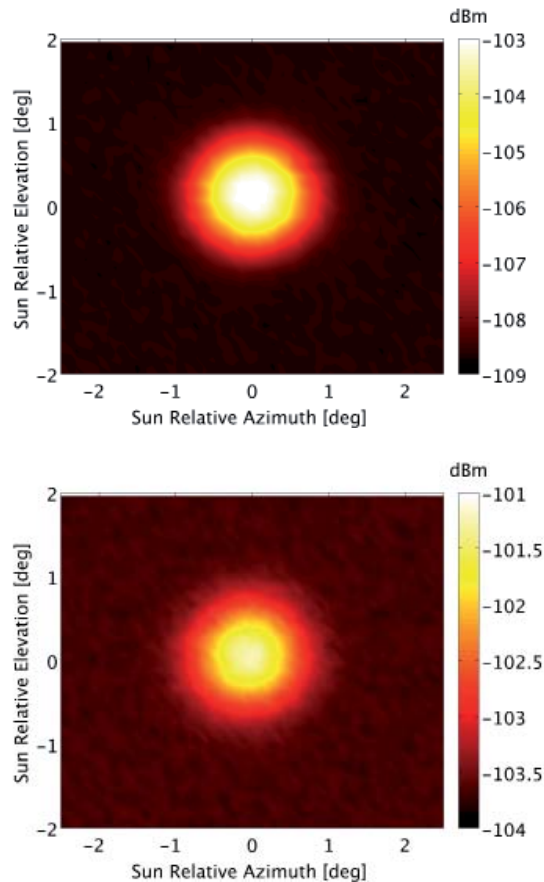

Figure 11. An example of the received power pattern (horizontal polarization) obtained via a solar scan with the NASA D3R radar at Ku (top) and Ka bands (bottom).

(e.g., Figure 10), with the elevation of the beam axis at the same elevation as the horn, can be used to determine the azimuth beamwidth. A Gaussian (or parabolic, on semi-log scales) fit to the data points near the beam axis (indicated by dots in the figure) identifies the 3 dB beamwidth in azimuth. If the fit is of the form $y(\text{dB}) = a\{x[\text{deg}] - b\}^2$, the 3 dB beamwidth will be $2(3/a)^{1/2}$. In Figure 10 the value was 1.04°. To determine antenna beamwidth in elevation, data from the same three-dimensional scan patterns can be used. However, to achieve higher precision, it is better to run several upward range-height indicator scans with the standard-gain horn radiating. It can be convenient to displace each scan by a small amount in azimuth to assure that at least one would go through, or very near, the horn’s location.

2.2.6 Antenna Pattern Measurements Using Solar Scans

The solar-scan utility can also be useful to determine the antenna pattern in the main lobe. As mentioned earlier, the sun can be considered as a standard noise source. Received power density at the antenna can be obtained from observatory S-band solar-flux values (adjusted for

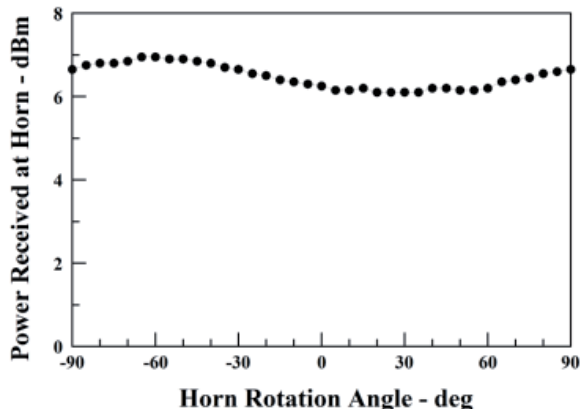

Figure 12. The power received at a standard-gain horn as a function of the horn's rotation angle, for a case where the polarization of the radiated signal was nearly circular (0° indicated V polarization for the horn).

attenuation by atmospheric gasses) that can be converted to the radar frequency at S-, C-, or X-band frequencies, according to published conversion tables [2, equation (4.1)]. For antennas with the same gain and receivers with the same bandwidth and noise figure, the power collected at the receiver is maximum at S band, whereas it can be lower by about 4.5 dB and 8.0 dB at C- and X-band frequencies, respectively. This makes it difficult at X band to get such pattern measurements. To obtain accurate results, the solar-scan utility should slowly scan the sun, taking into account the sun's movement, correcting for the size of the solar disk as well as any elevation-angle-dependent atmospheric distortion, and, finally, subtracting the receiver noise power. Figure 11 shows an example of the received power pattern at horizontal polarization for the NASA dual-frequency dual-polarized Doppler radar (D3R) at Ku (left) and Ka bands (right).

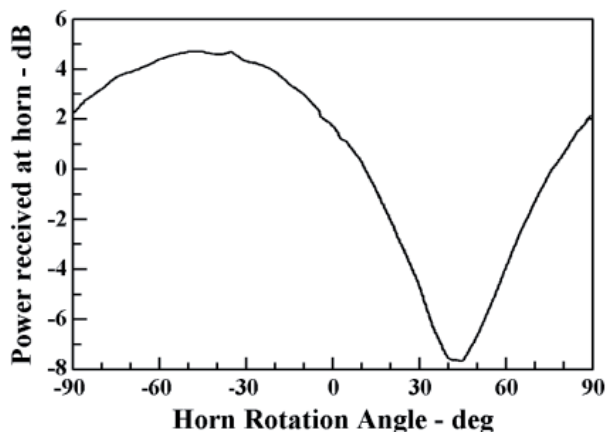

Figure 13. The power received at a standard-gain horn as a function of the horn's rotation angle, for a case where the polarization of the radiated signal was elliptical (0° indicated vertical polarization for the horn).

2.2.7 Polarization of the Transmitted Wave

The polarization of the signal radiated from a radar antenna can be obtained from measurements collected with the setup previously described. While the radar transmits its H and then V component (alternate-polarization scheme) or simultaneous H and V components (STAR scheme), the standard-gain horn is rotated in steps around the line-of-sight axis. At each rotation step, the power received by the horn is measured with a power meter.

A plot of the power received at the horn as a function of the horn's rotation angle, such as that of Figure 12, can be obtained. If the radiated signal is linearly polarized, this received power would exhibit a sharp minimum where the horn polarization is orthogonal to that of the signal. If the signal is circularly polarized, the received power would not vary as the horn is rotated, while elliptical polarizations yield intermediate variations. The plot in Figure 12, showing a variation that was less than 1 dB in a signal level that ranged between 6 dBm and 7 dBm, indicated that the current polarization of microwaves radiated from this radar antenna was nearly circular.

Figure 13 shows an example plot of power received at the standard-gain horn as a function of the horn's rotation angle, where the variation indicated an actual elliptical polarization. If desired, the axial ratio for an elliptically polarized signal can be determined by noting the maximum and minimum power levels in a plot like Figure 12. Taking the square root of those values (in power units, not dBm) yields quantities proportional to the sum and difference, respectively, of the amplitudes of the right- and left-hand circular E-field components of the elliptical signal. The quotient of the sum over the difference is the desired axial ratio. The inclination angle of the ellipse is indicated by the maximum or minimum value in the plot.

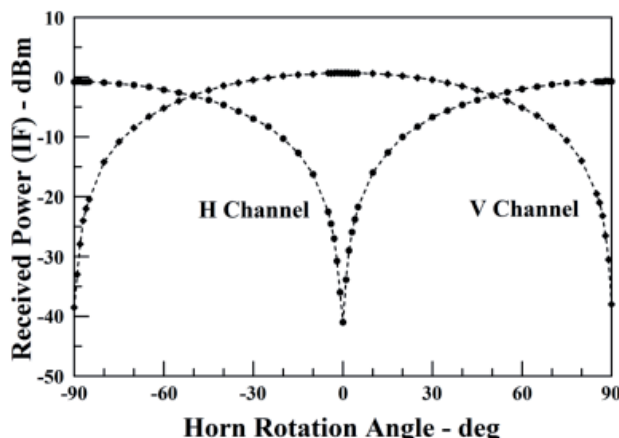

Figure 14. An example plot of the results obtained with a rotated horn transmitting to the radar.

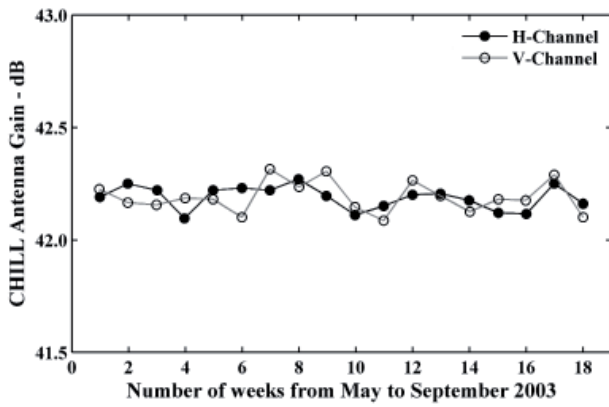

Figure 15. The antenna gain estimated weekly using solar calibration in H and V channels from May to September, 2003 (CSU-CHILL).

Another similar series of measurements using the reciprocal propagation path, with a signal generator as the source and the horn as the transmitting antenna, permits verification of the alignment of the H and V components of the antenna pattern. The horn is rotated as before, and the H and V components of the signal received are recorded to evaluate the orientation of the antenna’s H and V components. The received H component should exhibit a sharp minimum at the 0° horn angle (vertical polarization of the signal from the horn), while the V component should show a sharp minimum at ±90° (horizontal polarization of that signal). Figure 14 shows an example of the results of such measurements. Expanded-scale plots with finer resolution in the horn rotation angle around 0° and ±90° can be useful for detailed verification.

2.2.8 Effective Antenna System Gain

The antenna gain is defined as the maximum radiated power density relative to the power density that would be radiated from an isotropic antenna (it is sometimes referred to as directivity). Antenna gain is usually specified in the logarithmic unit of dBi (i.e., dB relative to an isotropic antenna). The nominal gain of a paraboloidal antenna of physical aperture area A , operating at wavelength λ , is expressed by the equation

$$G_{nom} = e_a \left(4\pi A / \lambda^2 \right) = e_a \left(\pi d / \lambda^2 \right), \quad (7)$$

where d is the diameter of a circular aperture, and e_a is the “aperture efficiency.” A typical value of e_a is 0.55. However, to facilitate measurements in the field, it is helpful to incorporate losses such as waveguide, mismatch, and radome losses into an “effective antenna system gain” [3]. Under that formulation, the effective efficiency may be considerably smaller. The antenna gain may also be

polarization dependent, so that the value could differ for the horizontally and vertically polarized signal components. A common method for evaluating the effective antenna system gain uses the pyramidal standard-gain horn as a transmitting antenna to send a signal (usually, CW) to the receiving radar antenna [3]. The classical Friis transmission formula provides the power received by the radar, P_r :

$$P_r = \frac{P_t G_t G_e \lambda^2}{16\pi^2 r^2}, \quad (8)$$

where P_t is the power transmitted from the horn (average power values can be used in both cases); G_e is the effective antenna system gain of the radar, to be determined; G_t is the gain of the standard-gain horn; λ is the radar’s operating wavelength; and r is the antenna-to-horn distance, obtainable from geodetic survey data or distance-measuring instruments. In these measurements, the signal-generator frequency needs to be tuned to place the IF signal in the receiver at the center of the IF filter’s pass-band. The calculated values for effective antenna system gain incorporate all waveguide, mismatch, and similar system losses beyond the directional couplers, as well as any radome loss. An equivalent measurement of antenna gain can be made using the reciprocal propagation path, with the radar transmitting to the standard-gain horn with an attached microwave power meter situated in the far field of the radar antenna. Here, the roles of “transmitted” and “received” in the Friis formula are reversed, but the approaches are otherwise similar.

2.2.9 Antenna Gain from Sun Measurements

A way to use solar measurements to obtain antenna gain is described below [4]. As a first step, using two noise sources (“hot” and “cold,” the equivalent temperatures of which are T_h and T_c , respectively) the noise bandwidth, B_n , is established (see the details in Section 2.3.5). The background temperature (that of blue sky, i.e., without pointing to the sun) is referred to as T_a , while the sun is taken into account with an excess temperature, T_s . An equation relating the power received from blue sky can be written as

$$P_a = k T_a B_n G_c, \quad (9)$$

while the excess solar received power, P_s , can be related to T_a and T_s through

$$P_s + P_a = k (T_s + T_a) B_n G_c, \quad (10)$$

These equations can be combined into

$$P_s = kT_s B_n G_c . \quad (11)$$

Using equations that will be detailed in Section 2.3.5 concerning noise-bandwidth measurements, the excess sun temperature can be expressed as

$$T_s = P_s (T_h - T_c) / (P_h - P_c) , \quad (12)$$

The antenna gain can be obtained using an equation relating the effective aperture of the antenna, A_e , the excess sun temperature, T_s , and the solar flux density, S :

$$A_e = kT_s / S , \quad (13)$$

This expresses the fact that the effective antenna collecting area is the ratio between the measured solar power density and the incident solar flux, close to the antenna. This relationship can be expressed in terms of the antenna-system gain, G_e , instead of A_e , as

$$G_e = \frac{4\pi kT_s}{S\lambda^2} , \quad (14)$$

or in logarithmic units,

$$G_e [\text{dB}] = Q [\text{dB}] - S [\text{dBS}] + T_s [\text{dBK}] + \text{corr} [\text{dB}] , \quad (15)$$

where $Q [\text{dB}] = 10 \log_{10} 4\pi k / \lambda^2$, and the term $\text{corr} [\text{dB}]$ has been added to take into account atmospheric gas attenuation, a 3 dB polarization correction due to an un-polarized signal associated with a singly polarized receiving antenna state, and beam filling. The solar power density at the antenna can be obtained from observatory S-band solar-flux values, properly converted to the radar-frequency frequencies. Figure 15 shows an example of the weekly estimation of antenna gain performed at CSU-CHILL in 2003.

2.2.10 Channel Crosstalk

The channel crosstalk can be estimated with the standard-gain horn radiating an H (or V) test signal and measuring the power received at the radar in both channels. The cross-polarized $H \rightarrow V$ power should be from 35 dB to 45 dB below the co-polar power received in the H channel when the horn is radiating a horizontally polarized signal. The converse measurement can be done with the corresponding $V \rightarrow H$ cross-polarized signal level.

2.2.11 Antenna VSWR and Other Measurements

Measurements of quantities such as the voltage standing-wave ratio (VSWR) or return loss in the antenna system are performed to evaluate mismatch discontinuities in the microwave paths in the antenna. If the power reflected from such discontinuities is excessive, the reflectivity calibration can be affected, and other problems such as overheating of the terminations in the circulators may arise; compensation for the reflections with the use of tuning stubs may then be necessary. Three approaches can be useful here. The simplest is to measure the reverse

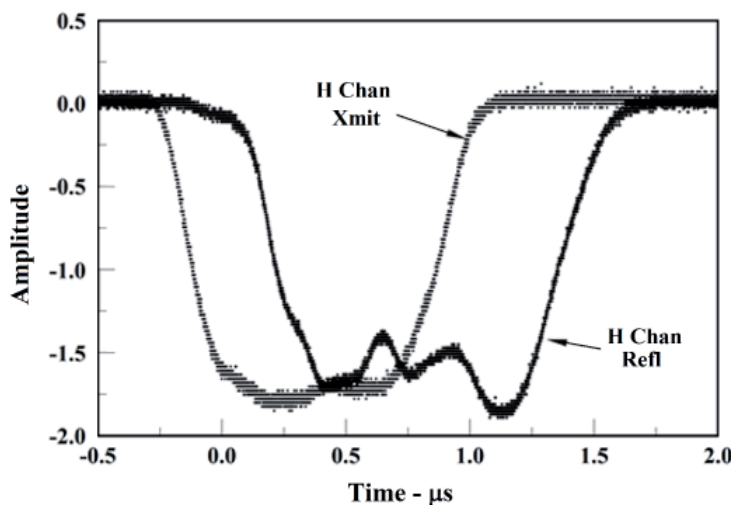

Figure 16. An example plot of the detected envelopes of the transmitted pulse and reflected signal in the CSU-CHILL H channel. The signal magnitudes were adjusted to facilitate timing comparisons.

power at the bidirectional couplers with a microwave power meter. These data may indicate mismatch problems in the waveguide, but provide no information about the location of the mismatch(es). For that purpose, comparing the envelope shapes and timing of the transmitted pulse and reflected signals in the waveguide (as measured with a crystal detector and oscilloscope) is useful. The most elaborate approach involves using a network analyzer to examine the reflections in the waveguide run, or segments thereof, as a function of frequency.

The VSWR or return loss can be determined by comparing the reflected power measured at the reverse port of a bidirectional coupler with the transmitted power observed at the forward port. For convenience, these measurements are usually phrased in terms of return-loss values, essentially the logarithm of the ratio of forward to reflected power in the waveguide at the directional-coupler location. A return loss of 20 dB corresponds to a 1.22 VSWR, and 17 dB corresponds to a 1.33 VSWR. A return loss of 20 dB or greater is generally regarded as indicating satisfactory matching of the waveguide to the transmitter, though no significant problems may be encountered even with somewhat smaller values. A 20 dB return loss means that 1% of the transmitted power is reflected, and 17 dB means 2% reflected. Reciprocity considerations invoke similar reflections of echo signals, for net 2% or 4% (0.09 dB or 0.18 dB), respectively, overall losses. With magnetron transmitters, higher levels of reflected power may occur when the transmitter is restarted after an extended off time. Such a restart is accompanied by slow changes in the frequency as the magnetron warms up.

The envelopes of the reflections of the transmitted pulses in each channel can be recorded with a suitable oscilloscope, using a crystal detector (with attenuator pads as necessary) at the reverse-power ports of the respective directional couplers.

The cable connecting the detector to the scope should match the output impedance at the coupler port (usually, 50 Ω ; RG-58 or equivalent) and be terminated in a matched load at the scope. Signal-timing information for comparison with a similar recording of the envelope of the transmitted pulse is obtained by synchronized triggering of the scope, so that the relative timing of the various signals is preserved. Figure 16 shows example results obtained with the CSU-CHILL radar operating in the normal configuration, with a plot of the transmitted pulse envelope overlaid for comparison. The relative-amplitude values in such comparisons between transmitted and reflected signals have no significance, because the coupling factors at the ports where the signals were recorded differed. Certain features could be seen in such plots. As was evident, the reflected signal did not necessarily preserve the shape of the transmitted pulse. Here, the reflected signal was delayed about 0.34 μs from the transmitted pulse. Since the group velocity in the WR284 waveguide at the CSU-CHILL frequency was about 200 m/ μs , this indicated an origin about 34 m along the waveguide. That placed the likely

origin at an impedance mismatch in the area of the azimuth rotary joint. The reflected signal continued for about 0.49 μs after the end of the transmitted pulse, indicating the arrival of a signal originating about 49 m down the guide: likely, from a mismatch at the feed horn. Reflections from multiple mismatch locations along the waveguide arrived back at the coupler at different times, with mutual interference effects modifying the resultant "pulse" shape. Power reflected from significant mismatches can cause difficulties, such as overheating of the terminating loads in the circulators. If the return-loss values are not high enough or there are other indications of such problems, it may be possible to isolate the major sources of the reflected signal by breaking into the waveguide at key points (e.g., the elevation rotary joints or the azimuth rotary joint), and affixing a dummy load. Comparing new return-loss measurements and signal-envelope plots such as Figure 16 with the original set can then indicate where the principal mismatch reflections are occurring. If tuning stubs are required, they should be installed on the transmitter side of the mismatch closest to the transmitter, and as near as convenient to that mismatch.

Interference among reflected-signal components originating from different mismatches along the waveguide can be constructive or destructive when they travel back toward the reverse port of the bidirectional coupler. This means that the net reflected signal will vary with frequency. At 2800 MHz, the wavelength in a WR284 waveguide is about 16 cm: a waveguide run of 40 m is thus some 250 wavelengths long. A frequency change of one part in 1000 (less than 3 MHz) would change the wavelength in this guide enough to make the total guide run $250 \pm 1/4$ wavelengths. The phase of the signal component reflected from a mismatch at the end of the run (i.e., from the feed horn) would change by 180° at the coupler, and accordingly modify the interference of that component with components reflected from other mismatches. Consequently, a shift in the transmitter frequency of just a few MHz may have a significant effect on the return loss and any problems associated therewith.

A network analyzer can be very useful in investigating such frequency-sensitivity issues. This instrument generates a CW test signal that can be injected into the waveguide through a coax-to-guide adapter. It then measures the ratio of the reflected signal power to that of the test signal (and hence, the negative of the return loss). It can be set to sweep over a frequency range (e.g., ± 10 MHz about the radar's transmitter frequency) in a series of small steps, while recording the ratio as a function of frequency. One should keep in mind that a) such network-analyzer data are in effect steady-state measurements, and take no account of the time delays inherent in pulse propagation along the waveguide; and b) the spectrum of a 1 μs radar pulse extends over a range of more than 1 MHz, centered on the nominal operating frequency. The return-loss values measured with a power meter may thus correspond in some sense to a kind of weighted average over the single-frequency values provided by the network analyzer, but the effect of the time delays also plays an important role.

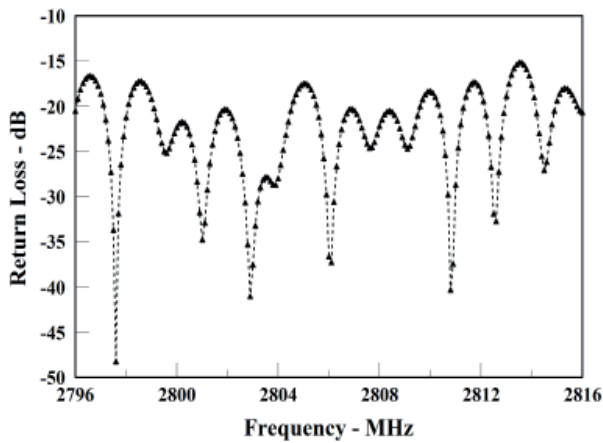

Figure 17. An example of the results from a network-analyzer sweep of the return loss (here, given with a negative sign) in the waveguide of an S-band radar, operating at about 2806 MHz (CSU-CHILL).

Figure 17 shows an example plot of data from a network analyzer sweep of the return loss in an S-band antenna system. This illustrates the complexity of the effects of frequency variations when multiple sources of mismatch reflections are located along the waveguide run. In this system, one might expect significant reflections from the coaxial azimuth rotary joint and the ortho-mode transducer (OMT) at the feed horn, along with lesser reflections from the elevation rotary joint and other sources, such as joints and bends along the guide run. Affixing a matching termination to the waveguide at points just ahead of the suspected mismatched elements can help to isolate the source of any mismatch causing significant reflected-power problems.

2.3 Receiver Measurements

The advent of fast analog-to-digital converters has enabled the implementation of radar receivers in which the received RF signal, after down-conversion to IF, is then digitized for further processing. Most modern radar digital-receiver systems implement utilities that make easier-to-perform receiver measurements.

2.3.1 Receiver Calibration

Some radar receivers make available routines that automate the calibration process that determines the digital IF output corresponding to an RF input test signal of increasing level, obtained from a signal generator tuned to the transmitted frequency, and injected through a directional coupler. (As noted at the beginning of Section 2, it is essential that the directional-coupler port used here be the same port as used for the transmitted-power measurements.) The measurements should include a noise-power measurement with the signal-generator RF signal turned off. Using

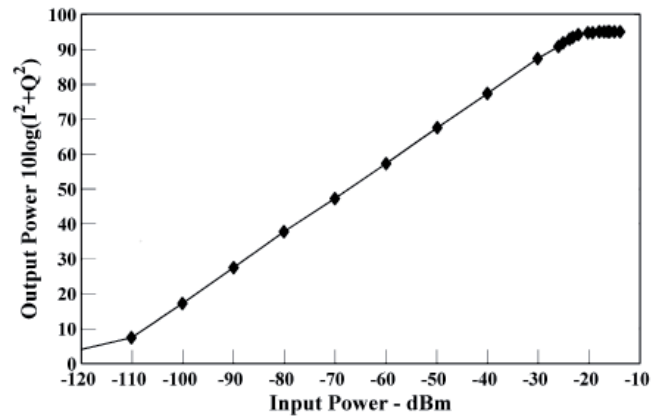

Figure 18. An example of a receiver calibration plot (CSU-CHILL).

different test-signal levels, the data are plotted on a log-log display, relating IF power at the receiver output to RF power at the directional coupler. The measurements above the system noise level determine relevant calibration parameters for received power and reflectivity calculations. For a linear receiver, this plot should be linear, and the slope should be unity (Figure 18). The radar signal processor then stores the appropriate calibration parameters for use during routine operations. For dual-polarization radar, it is important that such a process is applied to separate calibrations for both the H and V receiver channels. The measurements are sensitive to the temperature, especially of the receiver front end (such as low-noise amplifiers), and this calibration should be performed when system warm-up is completed. Additional input parameters can be requested by this calibration routine, such as values of antenna gain, the FIR filter loss, other losses, and the pulse duration.

2.3.2 Intermediate Frequency Filters and Associated Loss and Bandwidth

The bandwidth of the receiver in a radar system is typically determined by a filter in the IF section, the purpose being to enhance the received signal-to-noise ratio (SNR). In the calibration of the receiver subsystem, IF filters are important, because the magnitudes of both the signal and the noise output of the subsystem are related to the width of the filter response in the frequency domain. With digital filters, the filter coefficients also determine the “front-end gain” or “conversion gain” (from RF to IF power levels) of the receiver. Some radar signal processors let users set the width of the filter response, and determine the values of the filter coefficients, such that the output power from the filter corresponds to that of a CW IF signal entering the processor. An ideal filter matched to the spectrum of the transmitted signal would yield the highest possible SNR in the receiver.

However, in that neighborhood, the SNR is not very sensitive to modest increases in the filter's bandwidth, and somewhat wider bandwidth allows for possible variations in the transmitter frequency or pulse shape. Especially for magnetron systems, the width of the filters should take into account possible drift of the transmitting frequency (which can be up to several hundred kilohertz). This is driven by several factors, including temperature, age of the magnetron, delays in tuning of the automatic frequency control to the transmitter, and any shift in the pulse-repetition frequency.

To determine "filter loss," it is convenient to remember that in the context of receivers for weather radars, the term "loss" is defined with respect to infinite-bandwidth filters [1, Section 6.3]. The finite bandwidth of the receiving filter determines the loss in received power due to the varying effect of the filter transfer characteristics across the echo spectrum, which for weather targets, corresponds on average to the transmitter spectrum. The filter rejects part of the spectrum of the received signal, reducing the received power. Once the type of filter response is known (or the filter coefficients are known), the loss due to the filter can be easily calculated. The associated loss factor is calculated in principle by convolving the transmitter spectrum with the filter frequency-response characteristics. Values of received power measured during normal weather-surveillance operations need to be adjusted to take account of this loss.

Currently, most of the receivers are digital IF, and therefore this filter loss can be calculated from the filter coefficients. Moreover, the noise bandwidth (see also Section 2.3.3) can be directly calculated from the filter coefficients.

2.3.3 Receiver "Front-End" RF-IF Conversion Gain

As noted in the previous section, a proper selection of the coefficients in the digital filter can make the signal processor provide indications of absolute power levels at the input of the IF digitizer. Comparing these values obtained during the receiver calibration to the RF input signal levels at the directional coupler of the receiving channel, and adjusting for the IF filter loss (because the CW test signals are not subject to the filter loss) provides the net RF-to-IF conversion gain (G_c):

$$G_c = NL_{IF} [\text{dBm}] - NL_{RF} [\text{dBm}] + \text{Filter Loss} [\text{dB}] \quad (16)$$

where NL stands for noise level. This is the gain of the receiver "front end" that incorporates all of the analog components of the receiver, including the gains of the low-noise amplifier (LNA) and the IF amplifier, as well as losses in the waveguide, circulator, TR limiter, pre-selector filter, cables, pads, and mixer. While this may be considered a "detail," it is a good number to note once in a while, to

make sure nothing is drifting. The value is also useful in determining the receiver noise bandwidth and noise figure (Section 2.3.5).

2.3.4 Noise Power Levels

Noise power levels can be measured and stored for each channel, in a table or an electronic spreadsheet. The noise power is the lowest power level that appears as part of the receiver calibration. Correction of the echo power received from weather targets is needed to obtain valid measurements of differential reflectivity.

2.3.5 Receiver Noise Bandwidth and Noise Figure

The detection limit of the radar receiver is based on four factors: the noise figure (NF); the quantity kT , where k is Boltzmann's constant and T is the antenna temperature; the noise bandwidth of the system; and the SNR. The noise bandwidth is defined as the value which, when multiplied by the average input noise power per hertz and the receiver gain, results in the measured output noise of the system. This quantity is important in solar calibrations and receiver calibrations using noise sources, and is determined by the IF filters. Its value can be determined from two noise output measurements with two noise sources of known, but different, temperatures at the receiver input. The usual choices are the environmental temperature (290 K by convention, obtained using a matched termination or attenuator padding amounting to at least 20 dB as a dummy load), and the equivalent noise temperature of a standard noise source. The noise bandwidth is then calculated by using two equations of the form,

$$P = kTB_n G_c, \quad (17)$$

where P is the noise output power at IF from an element of noise temperature T connected at the receiver input, k is Boltzmann's constant, B_n is the noise bandwidth, and G_c is the conversion gain of the receiver. The two equations can be solved for the noise bandwidth as

$$B_n = \frac{P_s - P_d}{kT_s G_c}, \quad (18)$$

where subscripts s and d indicate measurements made with the noise source and with the dummy load in place, respectively. Here, T_s represents the excess noise temperature of the source (i.e., a noise source with an excess noise ratio of 15 dB corresponds to an excess noise temperature of 8307 K). Finally, the noise figure, F_n , can then be calculated from

$$F_n = \frac{P_d}{kTB_n G_c}, \quad (19)$$

Obviously, all the measurements must be at common reference points. The measurements of the noise-power output are normally taken as the IF power available also from the radar signal processor. However, it should be noted that the latter calculation may be only an approximation, because the receiver noise power output in the normal operating configuration may differ from that with the dummy load connected; the “antenna temperature” may hence not equal 290 K.

2.4 Dual-Polarization Tests

The quality of the Z_{dr} data is affected by the balance between the H and V transmitting and receiving channels. Information about these balances can be obtained from standard-gain horn measurements such as those discussed in Section 2.2.

2.4.1 Transmitting Channels

The balance between the H and V transmitting channels can be evaluated by comparing signals transmitted by the radar, received with the standard-gain horn, and measured using a power meter. This measurement can be affected by various factors, including any difference in transmitted power between the two channels, the uncertainties of directional coupler calibrations, or differences between the antenna gain or waveguide loss of the two channels.

2.4.2 Receiving Channels

The balance between the H and V receiving channels can be evaluated by applying equal inputs to the two channels. A suitable test signal transmitted from a signal generator and standard-gain horn can be adjusted in polarization by rotating the horn, for example, using first H and then V polarization, or with the horn at a 45° inclination. Alternatively, the solar microwave flux, which is non-polarized and therefore comprises equal H and V components, can be recorded.

2.5 Waveguide and Directional Coupler Measurements

2.5.1 Waveguide Losses

Measurements of loss in the different microwave paths are often part of routine maintenance or calibration operations. In most cases, it is not really practical to obtain a measurement of the overall waveguide loss that

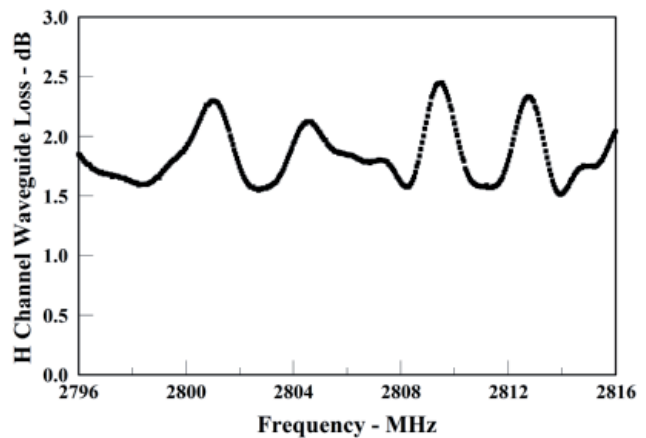

Figure 19. An example of the data from a network-analyzer sweep of the loss in a dual-polarized radar (CSU-CHILL).

encompasses the full waveguide run, from directional coupler to feed horn. Moreover, any loss measurement involves both the ohmic and mismatch losses along the guide. In complex dual-polarization systems, the mismatch losses can vary markedly with frequency (e.g., Figure 19). Consequently, waveguide-loss measurements are mostly useful for performance-monitoring purposes; measurements of effective antenna system gain adequately incorporate the losses for calibration purposes. The ohmic losses vary only slowly with frequency, and one might therefore expect measurements at only a single frequency to suffice. However, the mismatch reflections can be significant, and can vary much more markedly with frequency (as in Figure 19). Any loss measurements should thus actually cover a range of frequencies spanning the main part of the transmitter spectrum. This is especially important with magnetron transmitters, where substantial frequency variations can arise. As illustrated in Figure 19, a network analyzer can be employed to investigate waveguide-loss measurements as a function of frequency. In that example, the ohmic-loss component of the measurements was no greater than about 1.5 dB. It could have been less, because there was no assurance that the mismatch reflections completely canceled even at the minimum in the curve. However, the mismatch reflections could add another 1 dB or so (even more, in some cases) to the measured values.

It should be stressed that differing frequency-dependent losses in the two channels contribute to a frequency-dependent bias in Z_{dr} . Radar systems typically include several strategically located directional couplers that are used to safely connect built-in or external measurement devices. Monitoring the calibration of these devices is important for collecting reliable test measurements (although if the same forward port is used for transmitter power and antenna measurements as well as receiver calibration, the coupling factor cancels out of equations such as Equation (5), and the actual value is immaterial [5]). The same must be done for any attenuators that are

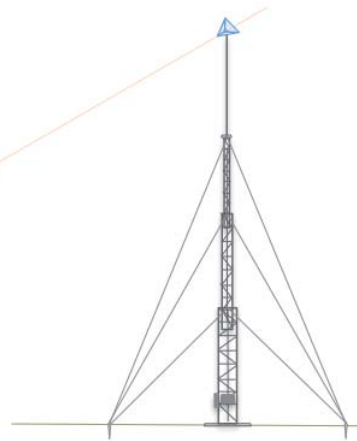

Figure 20. An illustration of the setup for calibration with a triangular trihedral corner reflector.

employed to protect measuring devices, such power sensors. These items are typically sent to calibration facilities for certification “testing.”

3. End-to-End Validation/ Verification of Calibration

The previous sections have shown that the tasks of characterizing each individual radar component or subsystem can be quite tedious. Fortunately, it is only necessary to conduct some of the tests on an occasional basis, or after some significant change to the system. For this reason, it can also be convenient to use methodologies to evaluate and characterize the radar system as a whole. These “end-to-end” calibration tests involve the measurement of returns from scatterers with known signatures, such as standard reflectors or spheres with known radar cross sections, or determining some measurable and reproducible properties of returns from precipitation. Active external sources such as the sun, although a valuable tool for some calibration and monitoring purposes, do not provide an end-to-end calibration. In the following, techniques based on point targets or properties of returns from the precipitation medium are described.

3.1 Point Targets

Metal spheres and corner reflectors have known radar cross sections, and are known standard targets for calibrating radars. The implementation of calibration experiments with trihedral reflectors, and suspended or floating metallic spheres, is described. Trihedral-reflector calibration can be routinely collected with permanent setups, while specific calibration experiments must be planned using balloon-borne or tethered metallic spheres.

3.1.1 Trihedral Reflectors

Trihedral reflectors are commonly used to routinely calibrate several categories of radar systems. Such a “corner reflector” is composed of three triangular conducting planes, oriented so that each section is perpendicular to the others. Figure 20 sketches a typical setup for corner-reflector calibration. The reflectivity factor is computed from the received power using Equation (5), which is rewritten in logarithmic units as

$$Z_e [\text{dBZ}] = \bar{P}_r [\text{dBm}] + C [\text{dB}] + 20 \log_{10} r [\text{m}], \quad (20)$$

$C [\text{dB}]$ is the radar constant, given by

$$C [\text{dB}] = 10 \log_{10} \left\{ \frac{1}{\pi^5 |K_w|^2} \left(\frac{2}{c\tau} \right) \left(\frac{4\pi^3}{P_r G_0^2} \right) \left(\frac{8 \ln 2}{\pi \theta_1 \phi_{11}} \right) \lambda^2 10^{21} l_p l_{rp} l_f l_d l_p \right\}, \quad (21)$$

where l_p, l_{rp} , are the transmitting and receiving path losses, respectively, and l_f, l_p, l_d are the receiver finite bandwidth power loss, Probert-Jones integral correction, and two-way radome loss, respectively. The reflectivity factor can also be obtained by estimating it with reference to the received power from the trihedral corner reflector:

$$Z_e [\text{dBZ}] = \bar{P}_r [\text{dBm}] + C_{cr} [\text{dB}] + 20 \log_{10} r [\text{m}] \quad (22)$$

C_{cr} is the radar constant for the case of a point target such

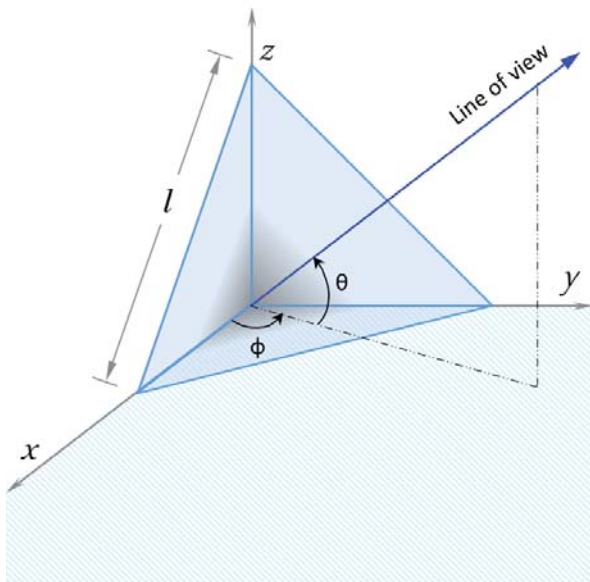

Figure 21. The geometry of a triangular trihedral corner reflector. The line of view is the direction of the boresight of the antenna beam with respect to the corner reflector.

as the corner reflector, given by

$$C_{cr} [\text{dB}] = 10 \log_{10} \left\{ \frac{1}{\pi^5 |K_w|^2} \left(\frac{2}{c\tau} \right) \left(\frac{\sigma_{cr}}{\hat{P}_{cr} r_{cr}^4} \right) \left(\frac{8 \ln 2}{\pi \theta_l \varphi_l} \right) \lambda^4 10^{18} l_f l_n l_p \right\}, \quad (23)$$

with \hat{P}_{cr} being the digitized received power from the corner reflector, r_{cr}^4 is the range from the corner reflector, σ_{cr} is the radar cross section (RCS) of the corner reflector, and l_n is the near-field antenna-gain loss for the point target. The calibration constant, C_{cr} , circumvents the use of well-calibrated measurements of the radar subsystems.

The radar cross section of a trihedral corner reflector is a function of the viewing angle of the radar beam. The maximum for a reflector with edge l is

$$\sigma_{cr} = \frac{\pi l^4}{3 \lambda^2}, \quad (24)$$

and this occurs for a line of view corresponding to $\theta = 35.25^\circ$ and $\varphi = 45^\circ$, which is the boresight of the corner reflector (Figure 21). In practice, it is not always possible to have a line of view that provides the maximum radar cross section. However, the trihedral reflector has a very wide field of view, and the reduction in RCS is small.

The RCS reduction is within ± 0.2 dB for angular offsets less than 5.0° . The RCS of the trihedral is affected by the angular errors between the faces of the trihedral. The angular error in the manufacturing of the trihedral reflector is defined as the maximum offset angle from the faces being orthogonal (i.e., at 90°). With modern manufacturing methods, the error is well within 0.1 dB. The errors in RCS are negligible for centimeter-wavelength radars, when compared to millimeter-wavelength radars.

There are several factors that must be taken into account while performing this calibration.

The configurations of the transmitted waveform and the receiver are very important for performing calibration with a corner reflector. The key elements pertain to the closest observable range gate and to receiver saturation. The received signal from a corner reflector can saturate the receiver in most systems. Receiver saturation can be eliminated by the addition of fixed attenuators in the front-end of the receiver, or by incorporating a system to lower the transmitter's peak power. The use of pulse-compression waveforms in systems using klystrons, TWTs, and solid-state transmitters puts a limitation on the location of the corner reflector, because of the blind-range issues related to the use of long pulses. The corner reflector must be located beyond the blind range, which may be much farther than the optimal region for locating the reflector.

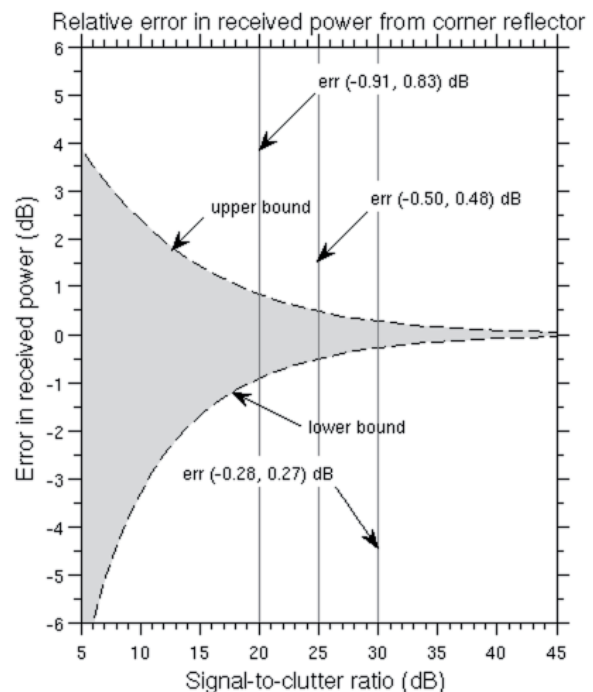

Figure 22. The bounds on the bias in the received signal power from a corner reflector as a function of the signal-to-clutter ratio.

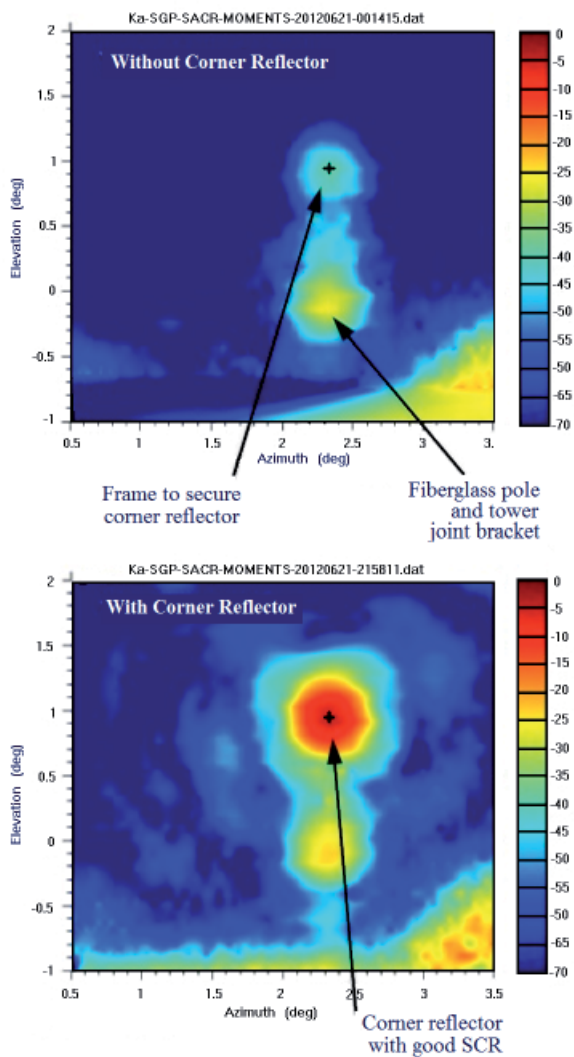

Figure 23. The received power (relative to a corner reflector) of a 55-foot tower, without (top) and with (bottom) a trihedral corner reflector (ARM Cloud Radar Ka-SACR).

The location of the reflector is very important to minimize the effect of ground clutter and multipath. The location is primarily determined by the antenna's beamwidth, because the cross-range resolution degrades with range. The factors that must be taken into consideration for the location of the corner reflector are the cross-range resolution, the height of the reflector above ground, and the line-of-sight. The range to the reflector must be selected such that the beam size is small, to avoid main-lobe clutter: if the beam is too wide, the main-lobe clutter will be too strong, and will introduce a bias in the calibration. The height of the reflector increases with range, and the requirements for the size of the tower become impractical if the reflector is too far away. To avoid this problem, the reflector can be placed in the Fresnel region of the antenna without significantly affecting the observations. The line-of-sight is defined in terms of the waveforms' ability to only observe the corner reflector, which means there should be no structures (towers, trees, buildings, etc.) within the volume of the pulse while

observing the reflector. Because the filtered echo from a point target is a smoothed version of the transmitted pulse, it is also important to be sure the corner reflector is situated in the middle of the filter response in range.

The corner-reflector calibration assumes that the received power corresponds to the radar cross section of the reflector. However, in practice, the received signal is contaminated by a clutter signal that biases the calibration constant, depending on the signal-to-clutter ratio (SCR) and phase alignment of the signals. Figure 22 shows the bounds on the bias introduced due to the presence of a ground-clutter signal. The bias is on the order of 0.25 dB or less when the signal-to-clutter ratio is greater than 30 dB. Observations with and without the reflector can be made to access the signal-to-clutter ratio. Since both ground clutter and returns from the reflector have zero Doppler velocity, frequency filters cannot be applied to suppress ground clutter. Figure 23 shows the observations of the corner-reflector region, with and without the reflector on the tower. The observations were made with the Ka-band scanning ARM cloud radar (Ka-SACR), which operates with a 0.33° beamwidth. With a reflector size chosen to have adequate RCS for Ka-band, it could be observed in Figure 24 that the signal-to-clutter ratio was sufficiently high to keep the bias within ± 0.25 dB.

In general, the data used in applications and retrievals are observations in the antenna's far field. However, to mitigate some of the practical issues with beam size and tower heights, the corner reflector is located in the Fresnel region of the antenna pattern, where the antenna's beam shape is already well formed, well beyond the near field of the antenna. The gain of the antenna is lower in the Fresnel region when compared to the far-field gain. The antenna patterns in the far field and in the Fresnel region for a circular aperture were simulated for Ka-SACR. The simulated patterns (with the corner reflector located at about

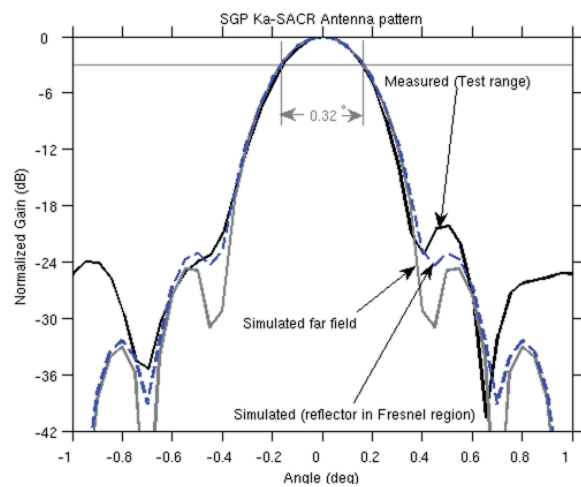

Figure 24. The antenna pattern of Ka-SACR from a test range, along with the simulated far-field and Fresnel-region antenna patterns.

460 m from the radar) are shown in Figure 24, along with the pattern measured in a test range. The beam shape was well formed, and closely matched the test range measurements in the main lobe of the antenna. The patterns shown in Figure 24 were normalized to the gain. The gain of the antenna in the Fresnel region was numerically computed to obtain the correction for the received power. The correction was small as the reflector locations approached the far field of the antenna. The environmental conditions in which the corner reflector observations are made have a significant impact on the usefulness of the data for calibration. There are three main environmental factors. One is the atmospheric state of the path between the radar and the reflector, which has a significant effect on the received power. At higher attenuating frequencies, the presence of precipitation biases any calibrations done with a corner reflector. Two, the state of the surfaces on the corner reflector has an impact on the received power. The presence of layers of water or icing on the reflector surfaces changes the RCS, and introduces larger uncertainties. Three, the state of the radar radome makes a significant contribution to errors in calibration. Under conditions of rain over the radome, a wet radome, or icing on the radome, the received power from a corner reflector cannot be used for calibration.

3.1.2 Calibration Sphere Experiment

Spherical conducting reflectors have well-known radar cross sections, depending on their diameter and radar wavelength ([1, Section 2.4.3]). They also have excellent polarization isolation with respect to linearly polarized waves, and can be used to establish the absolute physical



Figure 25. The preparation of a free-flying sphere for a calibration experiment at the CSU CHILL facility at the AMS Radar Calibration Laboratory in 2013.

diameter of a calibration sphere. The radar equation for a metal sphere in the boresight of the antenna, in the center of the along-range filter response, and in the far-field, can be written as

$$P_{ref(ms)} = \frac{\lambda^2 P_t G_0^2 \sigma_{ms}}{(4\pi)^3 l_{wg}^2 r_{ms}^4}, \quad (25)$$

where the subscript *ms* represents the metal sphere, and l_{wg} is the waveguide and radome loss, expressed as a numerical factor > 1 . Rearranging the terms of this radar equation gives the antenna gain:

$$G = \frac{G_0}{l_{wg}} = \sqrt{\frac{(4\pi)^3 r_{ms}^4 P_{ref(ms)}}{\lambda^2 P_t \sigma_{ms}}}, \quad (26)$$

where G_0 plays the role of the effective antenna system gain with the waveguide and radome losses factored in.

Calibration experiments can be implemented using either tethered or floating spheres. However, with a balloon-borne object, it is difficult to get the target (especially a moving target) centered within both the beamwidth and the along-range receiver filter response. Over-sampling the echo can assist with the latter, but considerable effort may be involved in acquiring the proper data. The typical implementation of the experiment makes use of a metallic sphere (aluminum, or just Styrofoam coated with a metallic foil), suspended by a tethered balloon. A 600 gram helium-filled balloon is sufficient to loft a 12 in diameter Styrofoam sphere wrapped with aluminum foil. The main disadvantages of this method lie in the uncertainty in the actual position of the sphere. The height of the sphere should be enough to avoid interference from ground targets, which is often a problem with tethered-sphere calibrations. A different implementation is the use of a free-flying sphere.

Figure 25 shows the preparation of a 12 in sphere and the balloon for a calibration experiment based on a free-flying sphere. The balloon was released and at first optically tracked with a theodolite, to a distance beyond some 5 km downwind of the radar. Its position was relayed to the radar operator, who then set a tight sector scan to cover the position of the sphere. The antenna gain was calculated with Equation (26), using the maximum received power of each traverse across the sphere. A histogram could be made from these gain calculations. Figure 26 reports the results of such a calibration experiment as performed at the CSU-CHILL facility. Further outcomes can be obtained from data collected during a sphere-calibration experiment. In addition to helping to obtain data with the sphere in the center of the along-range filter response, over-sampling of the echo in range can allow reconstruction of the transmitted pulse envelope. Figure 27 shows the good agreement in results obtained with 333 ns over-sampling of the echo of a 1.5 μ s pulse from a sphere.

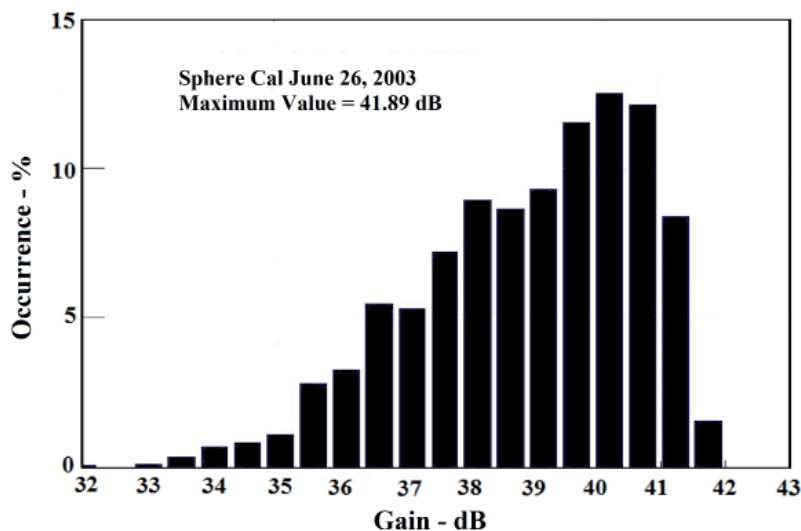

Figure 26. The estimation of the antenna gain using data from a sphere calibration experiment.

3.2 Permanent Scatterers

Cluttered echoes generated from permanent and spatially localized structures, such as towers or other buildings, collected at low elevation angles was suggested to monitor the stability of calibration in time [6]. This has been adopted at the NASA KPol S-band radar at Kwajalein Atoll [7] to check the day-to-day stability of radar calibration. The basic idea is that the stability of clutter echoes reveals the stability of the radar calibration, provided that no changes in structures are made, the radar elevation angle is constant in time, the contribution of precipitation does not dominate the contribution from clutter, and, finally, the effects of anomalous propagation can be neglected. The method starts from identifying cluttered bins in a scan collected in dry conditions using a low elevation angle (0.4° is used at K-Pol). On a daily basis, cumulative distribution functions (CDF) of equivalent reflectivities (dBz), recorded

at identified bins, are built. Of course, reflectivity data without clutter filtering must be used. Evaluation of the 95th percentile of daily cumulative distribution functions, subtracted from a baseline value, provides the RCA (relative calibration adjustment) in dB. The relative calibration adjustment is evaluated daily, regardless of the presence of precipitation, when the equivalent reflectivity is the sum of clutter and rain reflectivity, since it has been shown that the presence of precipitation does not alter the 95th percentile of the cumulative distribution function used to evaluate the relative calibration adjustment. At very short ranges (shorter than 1 km), the stability of cluttered bins has been evaluated to be better than 0.07 dB, while the daily fluctuation of relative calibration adjustment increased up to 0.21 dB within 10 km range. The use of this technique has allowed correlating sudden changes in relative calibration adjustment to damage or engineering events, and to shifts in elevation pointing.

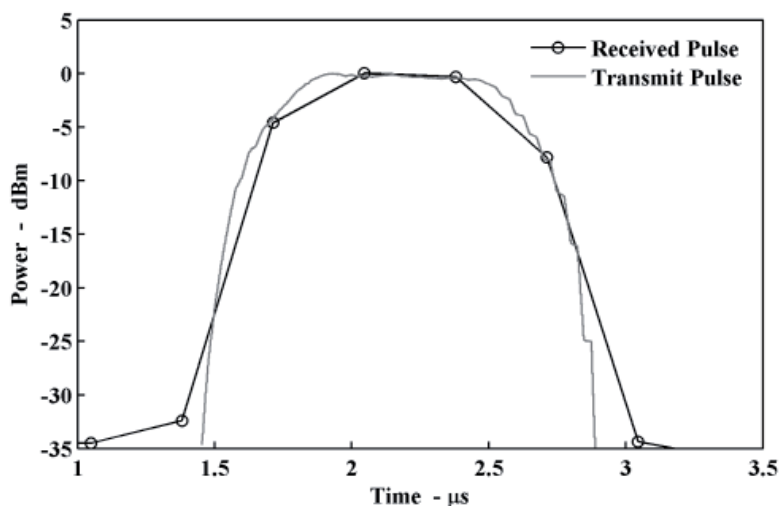

Figure 27. Comparisons of the directly-measured transmitted pulse and the estimated pulse waveform from the sphere's return (CSU-CHILL, experiment of September 23, 2011).

3.3 Returns from Precipitation

Weather radars are designed to sample distributed volume-filled targets, such as precipitation. To the contrary, the spherical or corner reflectors considered in the previous section are point targets, and not completely representative of the targets of main interest with weather radars. Echoes from precipitation have several properties that can reveal calibration biases, or can highlight other aspects characterizing the performance of the radar system. These methods have the advantage of being capable of being performed during routine operations, when suitable precipitation targets are available.

3.3.1. Differential Reflectivity Calibration

A commonly suggested option for calibrating Z_{dr} is the use of differential-reflectivity measurements collected at vertical incidence [8]. This method relies upon the assumption that due to the symmetry of the particles when viewed from below, the average Z_{dr} in precipitation should be zero at vertical incidence. In fact, cloud and precipitation particles have no preferential orientation in a horizontal plane: ice particles are usually randomly oriented, and on average, rain drops present a circular shape. Consequently, any observed departures from zero Z_{dr} can be ascribed to a bias of the radar system due to some differential response between the two channels, and a suitable offset correction can be applied to subsequent Z_{dr} data. Vertically-pointing differential reflectivity calibration measurements are usually performed with a rotating antenna, which implies that the polarization basis is rotated. Rotating the antenna should reduce the influence of azimuth dependencies of Z_{dr} , which may be caused by the possible presence of aligned hydrometeors (e.g., due to strong wind shear or electric fields), antenna-pattern sidelobes interacting with ground clutter, or backlobes that interact with precipitation [9], although the long-term average behavior should be azimuth-independent

(Figure 28). Measurements in the melting layer, or in layers with heterogeneous scatterers or strong gradients, should be avoided, because Z_{dr} would exhibit larger measurement errors. Many operational radars do not operate at vertical incidence, due to mechanical constraints. Other techniques use the collection of data at near-horizontal elevation in drizzle or light rain, thought to be mainly composed of very small and spherical droplets determining a $Z_{dr} \sim 0$ dB [8-10]: any deviation from 0 dB can be considered to indicate a Z_{dr} bias. However, it is sometimes difficult to clearly identify drizzle echoes (especially in low SNR). Otherwise, measurements exploiting the dependency on elevation of Z_{dr} measurements in stratiform rain and dry aggregated snow can be used. Calibration is obtained by comparing measured Z_{dr} profiles in elevation with the corresponding theoretical profile [10]. Several hours of uniform precipitation are needed to achieve accuracy within 0.1 dB.

3.3.2. Absolute Reflectivity Calibration

An absolute calibration of a weather radar can be established from measurements of Z_h , Z_{dr} , and K_{dp} in rain using the “self-consistency” among these measurements [11, 12]. The method is based on the relationship,

$$K_{dp} = aZ_h^b Z_{dr}^c, \quad (27)$$

where the coefficients a , b , and c depend on the assumed shape-size relation of raindrops, among other things. Suppose Z_{dr} is unbiased, and Z_h is affected by a bias B_h . Integrating the previous expression along a radial path $r_1 - r_2$, B_h can be obtained from

$$B_h [\text{dB}] = \frac{10}{b} \log_{10} [\Phi_{dp}(r_2) - \Phi_{dp}(r_1)]$$

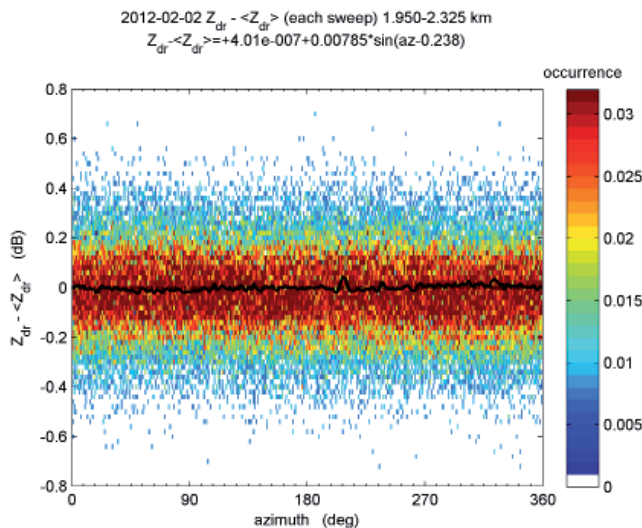

Figure 28. The differences between Z_{dr} measurements and sweep-averaged Z_{dr} as a function of azimuth during antenna measurements collected in three hours of measurements (02/02/2012 CNR Polar 55 C-band radar, Italy).

$$-\frac{20}{b} \log_{10} \int_{r_1}^{r_2} a_3 Z_h(r)^b Z_{dr}(r)^c dr. \quad (28)$$

Operational implementation of the method requires care. First, the self-consistency properties are valid only in rain: rain profiles contaminated by ground clutter, melting layer, or ice particles should be discarded. Second, the length of paths should be chosen to minimize the measurement error associated with the computation of the Φ_{dp} difference. When this method is used with attenuating frequencies, such as those at C or X band, or higher frequencies, the path attenuation, and eventually the attenuation induced by the wet radome, must also be corrected for. The coefficients of Equation (27) depend on the radar wavelength, temperature, and assumptions about drop-shape relationships. In general, working with such data is *only* a monitoring tool, and not a replacement for engineering calibration procedures. Because of the possibility of wide fluctuations in data, any observed calibration difference using precipitation data should be used as a clue suggesting very through engineering tests. Otherwise, it will create a situation of “circular argument.”

3.3.3 Other Polarimetric Measurements

In addition to the properties suggested in the previous section, other properties of dual-polarization measurements can be used as diagnostic tools. Information about performance that can be updated on a daily or on a per event basis helps to detect issues in the system. Most of these properties are relative to returns from rain. Some of them are summarized in the following:

3.3.3.1 Noise-Level Estimation

To obtain an ongoing measure of the receiver’s sensitivity, the noise from areas where precipitation returns

are absent (e.g., far ranges at high elevations) can be used to verify the actual noise level and its constancy in time.

3.3.3.2 Azimuth-Dependent Bias

In widespread light rain (20 dBz to 40 dBz), differential reflectivity should be essentially constant across all azimuths.

3.3.3.3 Daily Averaged ρ_{hv} Value in Rain

In homogenous precipitation, a value close to 0.99 is expected.

3.3.3.4 Azimuth-Dependent $\Phi_{dp}(0)$

The initial differential phase, $\Phi_{dp}(0)$, should be constant and independent of azimuth. Variation from the average could reveal radome or waveguide component degradation.

3.3.3.5 LDR Limit

The minimum detectable LDR (linear depolarization ratio) in systems with this capability provides an overall estimation of the cross-polarization isolation of the system.

4. Built-In Monitoring Tools and “Automatic Calibration”

Some of the detailed processes in the radar calibration operations discussed above require the involvement of expert personnel. Given the importance of calibration, weather radars can be equipped with some proper self-calibration “subsystems,” to allow continuous monitoring of

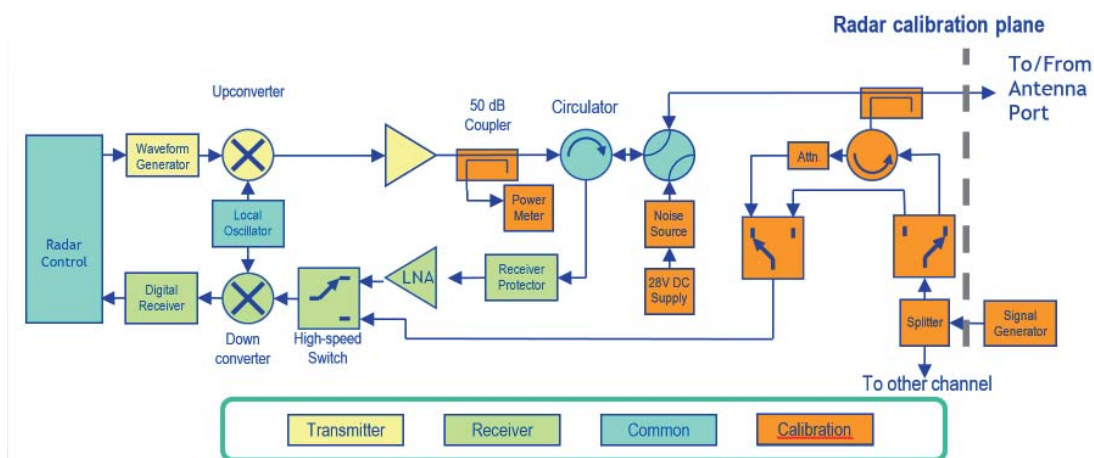

Figure 29. The CSU-CHILL radar configuration. Different colors were used to distinguish radar subsystems. Orange boxes identify the calibration subsystem. Only one polarization channel is shown.

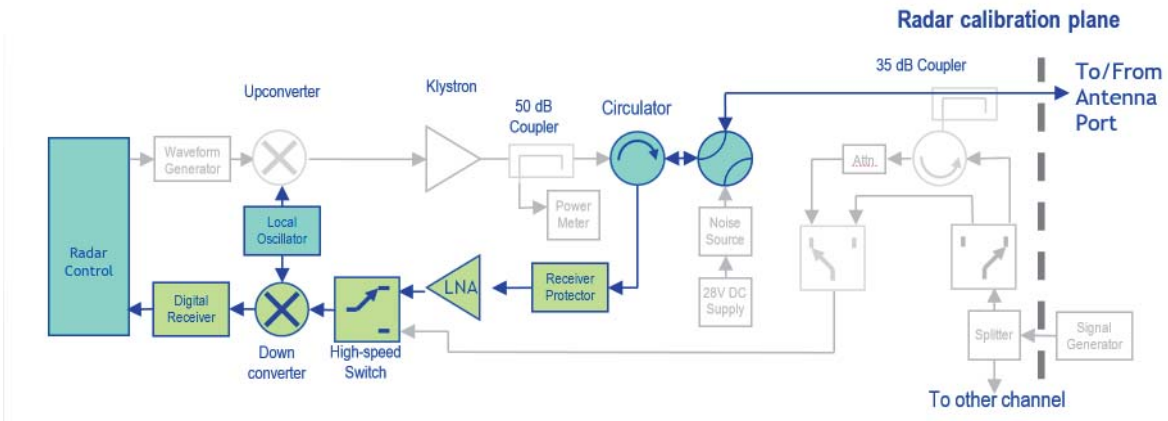

Figure 30. The configuration of Figure 29 in the normal receiving mode.

elements contributing to the variations in the calibration of the system. The concept to set up a built-in calibration system can be understood by looking at Equation (3), rewritten by explicitly grouping P_t and P_r in a ratio, to obtain

$$Z_e = \frac{1}{\pi^5 |K_w|^2} \left(\frac{2}{c\tau} \right) \left[\frac{(4\pi)^3}{G^2} \right] \left(\frac{8\ln 2}{\pi\theta_1\phi_1} \right) \lambda^2 r^2 \left(\frac{P_r}{P_t} \right), \quad (29)$$

Although mathematically equivalent to Equation (3), this formulation highlights the fact that reflectivity can in principle be determined by the measurements of a power ratio, rather than by two independent measurements of P_t and P_r . In fact, the mean power at the receiver in Equation (5) historically has been expressed by relating the equivalent reflectivity factor and the radial distance by a factor C , i.e., the radar constant that is included in P_t (e.g., [13]): $P_t = CZ_e/r^2$. In Equation (29), the only thing we need to monitor on a continuous basis is the ratio P_r/P_t , and this ratio can be measured by passing both signals through the same digital receiver. The main issue is that the losses in the measurement paths of transmitted power and received power are different. Elaborate strategies to do “proper bookkeeping” therefore have to be devised. The good news is these “loss terms” are constant.

4.1 CSU-CHILL Implementation

In this section, several schemes to collect the ratio P_r/P_t in a single sweep by taking into account the different paths needed to measure both quantities are illustrated. Given that today’s receivers can only process input signals of power typically up to approximately -25 dBm (see Figure 18), proper attenuators must be inserted to obtain transmitted power measurements with the receiver. Basically, switches in the microwave circuits permit automatic self-calibration in this manner, using the digital receiver and signal processor. As a first hypothesis, passive elements, such as waveguides and cables, are assumed to not significantly change between scheduled maintenance operations. The critical elements that may vary are the active components. During operations, system control can command periodic calibration procedures that characterize the active components to resolve any such unknowns. A calibration database can be used to detect anomalous calibrations, and flag them for further investigation. Figure 29 shows a schematic diagram of a radar implementing such circuits (CSU-CHILL was taken as a reference). All measurements are made with respect to the radar-calibration plane, which was set in this case at the forward port of the 35 dB bidirectional coupler.

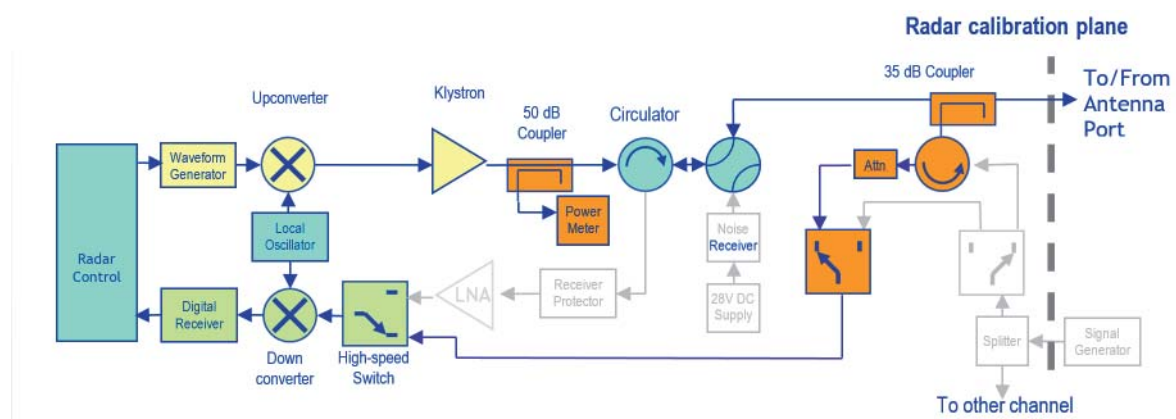

Figure 31. The configuration of Figure 29 for pulse transmission measurements.

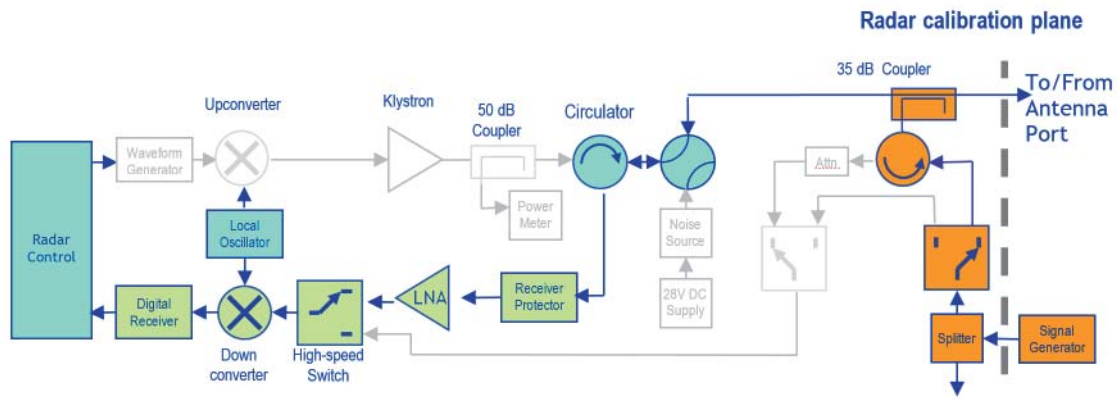

Figure 32. The configuration of Figure 29 for low-noise amplifier and down-converter gain-calibration mode.

In the standard receiving configuration (Figure 30), a high-speed switch is set to the receiving position after a fixed delay, $\Delta\tau$ ($3 \mu\text{s}$ for CSU-CHILL), from the transmitted pulse. Returns pass through the circulator, and get into the usual receiving channel, passing through the low-noise amplifier (LNA) and the down-converter to the digital receiver.

If the antenna receives a power P_{RX} , the digital receiver has IF input $S_{RX} = P_{RX} + G_{LNA} + G_{DC}$, where G_{LNA} and G_{DC} are the gains of the low-noise amplifier and down converter, respectively. Both G_{LNA} and G_{DC} need to be determined, or they can be grouped into the composite front-end conversion gain, G_c .

The configuration of Figure 29 can be set up to measure the transmitted pulse as shown in Figure 31. Within the transmitted pulse and the subsequent $\Delta\tau$ delay, the high-speed switch is set in the *cal* position to measure the transmitted power, using the digital receiver and the same RF-chain active components as the received signal, except for the low-noise amplifier and receiver protector. Compared to a different configuration with a switch in front of the low-noise amplifier, this configuration avoids the associated

increase in the noise figure. With this configuration, the digital receiver measures the power $S_{TX} = P_{TX} + G_{DC}$ (the attenuator is suppressed, being a known value). To determine these unknowns in the configuration of Figure 29, a known signal power, P_{TEST} , is injected into the radar reference plane from an RF signal generator, as in Figure 32. This measurement is done during data collection by pulsing the signal generator at a fixed range offset. The digital receiver measures $S_{TEST} = P_{TEST} + (G_{LNA} + G_{DC})$. Since P_{TEST} is known, $(G_{LNA} + G_{DC})$ is obtained directly from S_{TEST} . To resolve the separate estimation of the low-noise amplifier and down-converter gains, the configuration in Figure 33 is adopted. A signal of known power, P_{TEST} , is injected into the calibrator from the RF signal generator. The digital receiver now measures $S'_{TEST} = P_{TEST} + L_{coupler} + G_{DC}$, where $L_{coupler}$ is the loss of the coupler. Since $L_{coupler}$ is known, G_{DC} can be computed, and G_{LNA} can be determined from the $(G_{LNA} + G_{DC})$ previously estimated.

A further element that can be estimated using this configuration is the receiver's noise figure. To measure the noise figure (NF), a noise source of known excess noise ratio (ENR) is used. Noise figure calibration using the Y-factor method can be obtained as follows, using the radar in the configuration shown in Figure 34. At step 1, noise from a

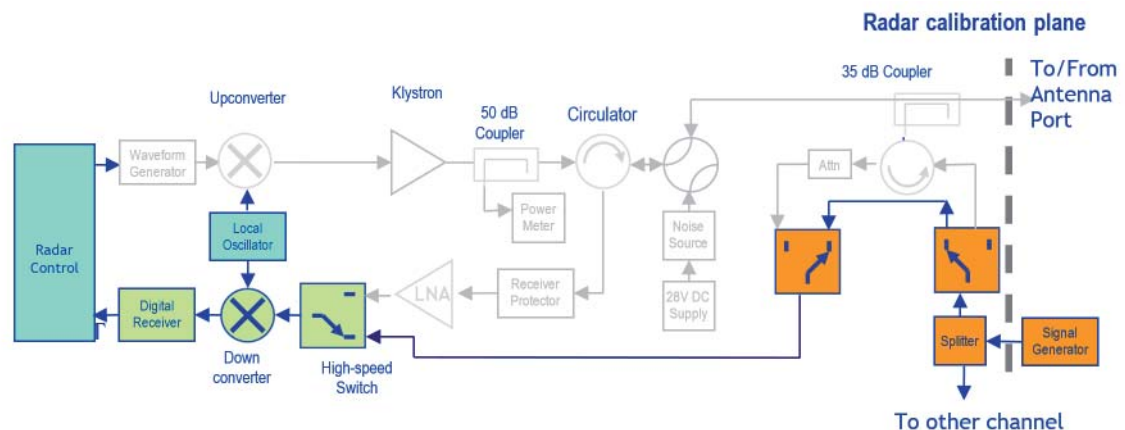

Figure 33. The configuration of Figure 29 for down-converter gain-calibration mode.

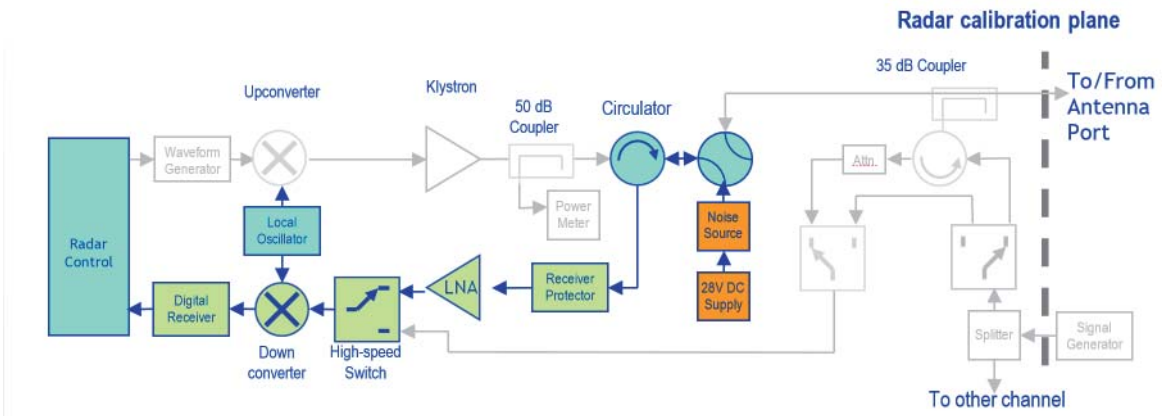

Figure 34. The configuration of Figure 29 used to determine the receiver’s noise

source of known excess noise ratio is injected, and the digital receiver measures S_{HOT} . At step 2, the 28-volt supply is turned off and the power from a “cold” source, S_{COLD} , is measured by the digital receiver. Finally,

$$NF = ENR - 10 \log_{10} \left[10^{S_{HOT} - S_{COLD} / 10} - 1 \right] \text{ [dB]} \quad (30)$$

allows one to determine the noise figure in dB.

4.2 Systems with Magnetron Transmitters

With systems using a magnetron transmitter, the automated calibration process must take into account a possible shift of operating frequency. An onboard calibration signal source allows automatic measurement of the gain of the receiving chain. Passing a sample of the transmitted pulse through the calibrated receiving chain allows keeping track of the changes in transmitted power, decoupling them from receiver-gain changes over time and/or frequency.

If the transmitter is expected to operate in a broad frequency band, a broad-band signal source and an automatic-frequency-control (AFC) style frequency-measurement tool can be employed to measure receiver gain at the frequencies of interest, and to select the appropriate values during operation of the radar. Again, having an onboard calibration source allows repeating/automating the process as deemed necessary to track changes in time. With reference to the scheme of Figure 35 (the path represented as a dotted line), to calibrate the receiver, a calibrated signal source is used. The joint receiver and data-acquisition system (DAQ) gain can be characterized at the transmitter frequency (or frequencies) of operation as

$$G(f, t) = P_{SRC}^{DAQ}(f, t) - P_{SRC}(f) + G_{DX}(f), \quad (31)$$

where $G_{DX}(f)$ represents the gain characterization of

the duplexer (this is a one-time measurement that can be done with a network analyzer). This equation allows referencing gain to the antenna ports where the radar equation is applied. Concerning transmitter measurements (Figure 35, dashed line), an initial measurement of the transmitted pulse power at the antenna port(s) is paired with the corresponding pulse sample measurement at the data-acquisition output, imposing

$$P_{TX}^{ANT}(f_0, t_0) \equiv P_{TX}^{DAQ}(f_0, t_0), \quad (32)$$

Transmitted power measured at the data-acquisition system’s output is corrected for receiver-gain variations to establish changes in transmitted power:

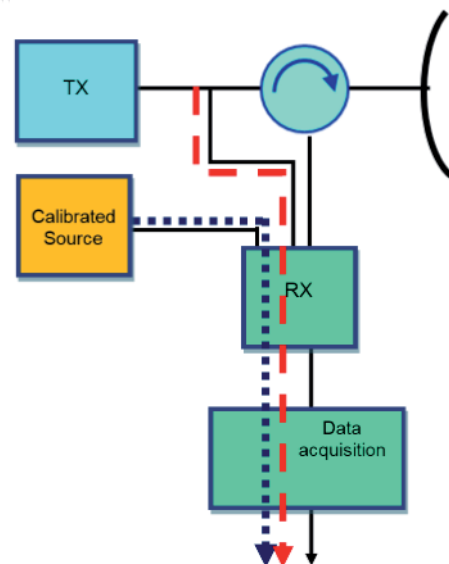

Figure 35. The configuration of calibration paths of a radar with a magnetron transmitter using a calibrated source. The receiver and transmitter calibration paths are shown in dotted and dashed lines, respectively.

Instrument	Use	Comments
Attenuator	Protect whatever test instrument	
BITE	Routine monitoring	
Clinometer or gunner's quadrant	Servo/antenna data system verification	Expert operator required
Crystal detector	Signal envelope measurements	Used with oscilloscope, matched-impedance cable and termination
Dummy load	analysis of reflected signals, Noise figure measurements,	
Metallic sphere	End-to-end calibration	
Network analyzer	VSWR; waveguide loss	
Oscilloscope	Shape of transmitted pulses/ reflected signals	
Power meter	Transmitted power; antenna measurements	Average power measurements preferred
Pyramidal standard gain horn	Antenna pattern and antenna gain measurements	
Signal generator	Antenna calibration; Receiver calibration	
Solar-scan utility	Antenna positioning; Antenna radiation pattern	Implemented at signal processor level
Spectrum analyzer	Transmit spectrum	
Trihedral corner reflector	End-to-end calibration	Permanent setup possible

Table 1. A summary of calibration equipment.

$$\Delta P_{TX}^{DAQ}(f, t) = P_{TX}^{DAQ}(f_0, t_0) - P_{TX}^{DAQ}(f, t) - [G_{RX\ DAQ}(f_0, t_0) - G_{RX\ DAQ}(f, t)], \quad (33)$$

The transmitter-receiver calibration values can finally be incorporated into the radar equation as

$$Z_e = \frac{2}{c\tau} \frac{c^2 (4\pi)^3}{f^2 G_0^2} \frac{8 \ln 2}{\pi \theta^2} \frac{r^2}{\pi^5 |K_w|^2} \frac{P_{RX}^{ANT}}{P_{TX}^{ANT}}, \quad (34)$$

where the knowledge of the transmitted frequency is used to select the appropriate calibration values.

5. Conclusion: The Calibration Protocol

5.1 Inventory of Techniques and Equipment

Previous sections have shown that calibrating a weather radar requires a combination of different techniques, corresponding to each subsystem. Several instruments are required. Moreover, the proposed techniques need to be implemented on a regular basis, with a calibration discipline, and also with proper instruments. Table 1 presents a list of the instruments necessary to perform the calibration procedures introduced so far.

5.2 Recommended Practice

Table 2 provides an overview of the techniques introduced so far, with a short description, and the recommended frequency of implementation. Summarizing, a minimum set of procedures to be implemented is that described below:

1. Receiver calibration –once every scan
2. Transmitted power monitoring: continuous
3. Sphere calibration: once per year
4. Z_{dr} calibration: every volume scan with the modern operational calibration system. Vertical looking: Target of opportunity. Solar measurements: can be done routinely every day.
5. Solar calibration monitoring and ground target monitoring can be done very regularly and frequently.
6. Overall, a once-per-year calibration campaign is recommended

Finally, calibration requires discipline to avoid rearrangement of equipment/connections. This is perhaps the most complicated of all the calibration procedures discussed, since some of them require stoppage of regular data collection. This should be scheduled based on weather forecasts to avoid loss of critical data. Documenting operations is a crucial aspect of calibration, and of other maintenance operations, as well. Specific tables that eventually can take the form of a spreadsheet are a necessary tool to track operations and record the results of calibration.

6. Acknowledgments

The authors acknowledge the various agencies that have helped them develop the concepts of calibration over the years, namely, NASA, the National Science Foundation, the US Department of Energy, and the Department of Civil Protection of Italy. The authors also acknowledge the staff of the CSU CHILL radar and the Kwajalein KPOL radar for their contributions to the techniques and measurements reported here.

Parameter	How to Conduct	Recommended Frequency
Transmitting frequency	Counter, frequency meter, or spectrum analyzer	Daily
Pulse shape	Crystal detector and oscilloscope	Weekly
Transmitted spectrum	Spectrum analyzer	Once a year, unless transmitted signal changes
Transmitted power	Power meter	Daily
Transmitted power stability	BITE	Continuous
Receiver calibration	Signal generator	Weekly
Receiver calibration stability	BITE	Once every scan
Antenna orientation	SSU	Quarterly
Antenna return loss (VSWR)	Power meter	Weekly
Corner reflector	Fixed setup as in Section 3.1.1	Continuous when possible
Sphere calibration	Tethered or free-floating sphere, depending on logistics	Once a year
Z_{dr} calibration, vertical-looking scans	Section 3.3.1	When suitable precipitation occurs overhead
Z_{dr} calibration, solar measurements	Solar measurements	Can be done routinely every day.
Solar calibration monitoring		Can be done very regularly and frequently
Ground target monitoring	Routine or special scans	Can be done every scan if target is routinely visible
Calibration campaign	As described in Section 2, including standard-gain horn measurements	Once a year

Table 2. A summary of calibration practices.

7. References

1. V. N. Bringi and V. Chandrasekar, *Polarimetric Doppler Weather Radar: Principles and Applications*, Cambridge, Cambridge University Press, 2001.
2. K. Tapping, "Antenna Calibration Using the 10.7 cm Solar Flux," Preprints, Workshop on Radar Calibration, January 2001 Albuquerque, NM, American Meteorological Society, available at http://www.k5so.com/RadCal_Paper.pdf.
3. G. E. Evans, *Antenna Measurement Techniques*, Norwood, MA, Artech House, 1990.
4. J. F. Pratte and D. G. Ferraro, "Automated Solar Gain Calibration," Preprints, 24th Conference on Radar Meteorology, Tallahassee, FL, American Meteorological Society, 1989, pp. 619-622.
5. P. L. Smith, Jr., "The Measurement of Antenna Gain in Radar Systems," *Microwave J.*, **17**, April 1974, pp. 37-40.
6. R. E. Rinehart, "On the Use of Ground Return Targets for Radar Reflectivity Factor Calibration Checks," *J. Appl. Meteor.*, **17**, September 1978, pp. 1342-1350.
7. D. S. Silberstein, D. B. Wolff, D. A. Marks, D. Atlas, and J. L. Pippitt, "Ground Clutter as a Monitor of Radar Stability at Kwajalein, RMI," *J. Atmos. Oceanic Technol.*, **25**, November 2008, pp. 2037-2045.
8. T. A. Seliga, V. N. Bringi, and H. H. Al-Khatib, "Differential Reflectivity Measurements in Rain: First Experiments," *IEEE Transactions on Geoscience Electronics*, **17**, October 1979, pp. 240-244.
9. J. C. Hubbert, V. N. Bringi and D. Brunkow, "Studies of the Polarimetric Covariance Matrix: Part I: Calibration Methodology," *Journal of Atmospheric and Oceanic Technology*, **20**, 2003, pp. 696-706.
10. R. Bechini, L. Baldini, R. Cremonini, and E. Gorgucci, "Differential Reflectivity Calibration for Operational Radars," *Journal of Atmospheric and Oceanic Technology*, **25**, September 2008, pp. 1542-1555.
11. E. Gorgucci, G. Scarchilli, and V. Chandrasekar, "Calibration of Radars Using Polarimetric Techniques," *IEEE Transactions on Geoscience and Remote Sensing*, **30**, September 1992, pp. 853-858.
12. G. Scarchilli, E. Gorgucci, V. Chandrasekar, and A. Dobaie, "Self-Consistency of Polarization Diversity Measurement of Rainfall," *IEEE Transactions on Geoscience and Remote Sensing*, **34**, January 1996, pp. 22-26.
13. L. Battan, *Radar Meteorology*, Chicago, The University of Chicago Press, 1959.



Tayfun Akgül

Istanbul Technical University
Dept. of Electronics and Communications Engineering
Telecommunications Division
80626 Maslak Istanbul, Turkey
Tel: +90 212 285 3605; Fax: +90 212 285 3565
E-mail: tayfun.akgul@ieee.org

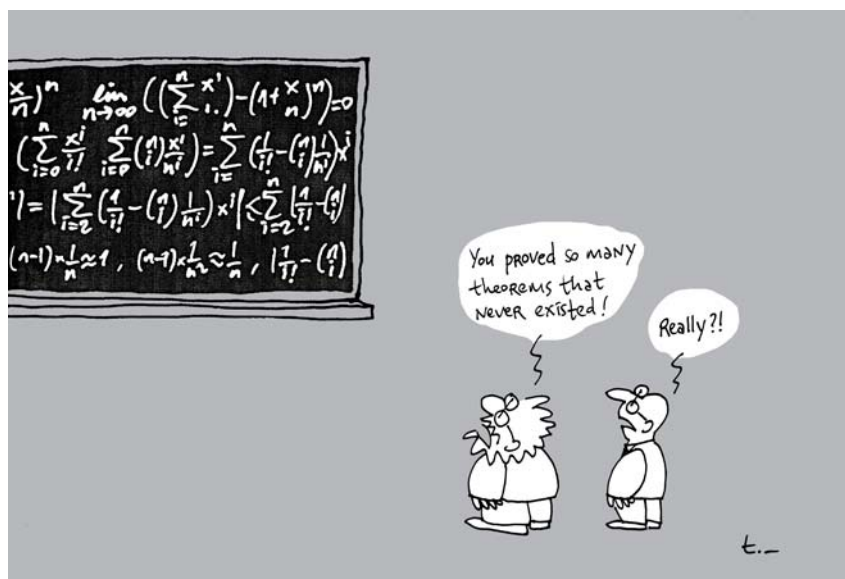



Stefan J. Wijnholds

Netherlands Institute for Radio Astronomy
Oude Hoogeveensedijk 4
7991 PD Dwingeloo, The Netherlands
E-mail: wijnholds@astron.nl

Editor's Introduction

At the URSI GASS 2015 in Beijing, an Early Career Representative (ECR) was elected for each of the Commissions (a few Commissions even appointed two ECRs). The ECRs should help to make URSI more attractive for radio scientists in the early stages of their scientific careers. As Chair of the ECR Committee (and one of the two ECRs of Commission J), I am grateful to be able to work with the enthusiastic young talents that the Commissions managed to find to fulfill the newly formed ECR positions. Since our appointment, we have participated in the organization of the General Lectures at the AT-RASC in Gran Canaria, and some of us participated as organizers of special sessions at that conference. We also provided advice on ways to improve the visibility of URSI, and on the future of the *Radio Science Bulletin (RSB)*. It was great to see that our conclusions on the latter aligned well with the steps that Ross Stone was already taking to bring the *RSB* to a higher level. One of the initiatives he introduced in that context was to start a series of columns. We are very happy to see that one of these columns is specifically dedicated to the ECR Committee.

In this column, we want to provide a forum to communicate ideas and happenings in radio science that are of interest to people in the early stages of their career, and to those helping early-career researchers. This scope covers a wide range of topics, varying from “Grant Proposal Writing 101,” to announcements of specific events geared towards early-stage researchers, to interviews with senior researchers on their careers. In this inaugural column, we are very happy to have a contribution on URSI as an organization by Phil Wilkinson (URSI Past President) and Paul Cannon (URSI President). At URSI conferences, I always notice that the structure of URSI is quite elusive, even to many senior radio scientists. I would like to thank Phil and Paul for providing a nicely concise overview of URSI, which, I think (and hope) will be useful to many radio scientists, in particular the young ones.

Since both the ECR Committee and this column are new initiatives, we are very open to suggestions. If you are organizing an event that is of particular interest to young scientists or have another suggestion for a contribution to this column, please let me know. The same holds for any idea that you may have for URSI to reach out to early-stage researchers. I am looking forward to your suggestions!

URSI: Your Scientific Union

Phil Wilkinson¹ and Paul Cannon²

¹Past President of URSI
Editor-in-Chief, *Radio Science*
E-mail: phil_wilkinson@internode.on.net

²School of Electrical, Electronic and Systems Engineering
Room N431, Gisbert Kapp Building, University of Birmingham
Edgbaston Birmingham B15 2TT, United Kingdom
E-mail: p.cannon@bham.ac.uk

The International Union of Radio Science (URSI) serves a community of people with a common interest: radio science. Like all groups, there are some people with a peripheral interest, who remain participants for only a short period of time, and others whose energy and enterprise sustain the entire community. One way of viewing this is to think in terms of three clouds, shown in the accompanying figure (Figure 1). On the left is a large cloud of radio scientists containing URSI, in an embracing circle, and to the right, two subordinate, but very important clouds, representing the national and international science communities. This short note provides a personal perspective on some of the interactions within these clouds, and their importance for URSI and radio science.

URSI was formed about 100 years ago, at the beginning of the 20th century, when radio studies were at the vanguard of science and the first transformational ripples of relativity and quantum physics were being recognized. In 1931, URSI became a founding member of ICSU (now the International Council for Science), which was a coalescence of science bodies.

Today, with 15% of the 21st century already gone, and applications of radio science permeating all modern culture, URSI continues to offer a vehicle for promoting radio science. But, how does this happen?

URSI (<http://www.ursi.org/>) gains its identity from the international community of radio scientists, who in turn are members of both the international and national science communities (the right-hand clouds). Formal structures (circles within the clouds) exist at both the national and international level for guiding science in advantageous ways. Individual scientists may participate in these processes, be detached from them, or even be unaware of them. Nevertheless, URSI acts on behalf of all radio scientists in dealing with these communities.

URSI deals directly with the national science community through its Council, the members of which are delegates from the various national radio science committees. Ideally, URSI has similar strong links into the international science community through its dealing with the other scientific Unions that form ICSU.

Over time, URSI has developed a structure that supports these interactions, and this is shown within the embracing circle in the left-hand cloud. On the left-hand side of the circle is the science structure; on the right is the administrative structure. Neither has a purpose without the other, and it is vital that there is ongoing communication between the two parts, especially if URSI is to influence the wider science community.

The triennial URSI General Assembly and accompanying Scientific Symposium (GASS) is the key entry in the URSI calendar. It is the role of Council to decide the direction for URSI over the forthcoming triennium. This includes the election of the President, four Vice-Presidents, and a Secretary General to the Board, and endorsement of the election of individual scientists who agree to contribute their time and skills through the various Commission-led offices. Council decisions are implemented during the triennium by the Board, which is supplemented with co-opted Assistant Secretary Generals. The Board, in turn, develops policy and brings recommendations to the General Assembly based on experience gained during the triennium.

The Scientific Symposium, which takes place during the GASS, is the domain of the Commissions, supported by their Working Groups (WGs). The ten Commissions of URSI provide a representative cross-section of radio science relevant in the 21st century, and are responsible for ensuring the relevance of their guiding terms of reference. The Commissions consist of the elected officials, the appointed delegates from the parent National Committees of radio science, and individual radio scientists. The strongest links within URSI are those between the Commissions and the radio scientists. The Commissions are responsible for developing a successful scientific symposium, and for providing an overview of their segment of radio science. Much of the work for this takes place during the GASS, when topics of developing importance are identified and sessions are proposed. Radio scientists must then support their Commission Chairs over the next three years as these ideas are brought to fruition. Ideally, Commissions also contribute to the *Radio Science Bulletin*, offering articles that focus on recent significant science developments in their domain. During the triennium, the Board assists the Chairs in bringing the Scientific Symposium sessions together.

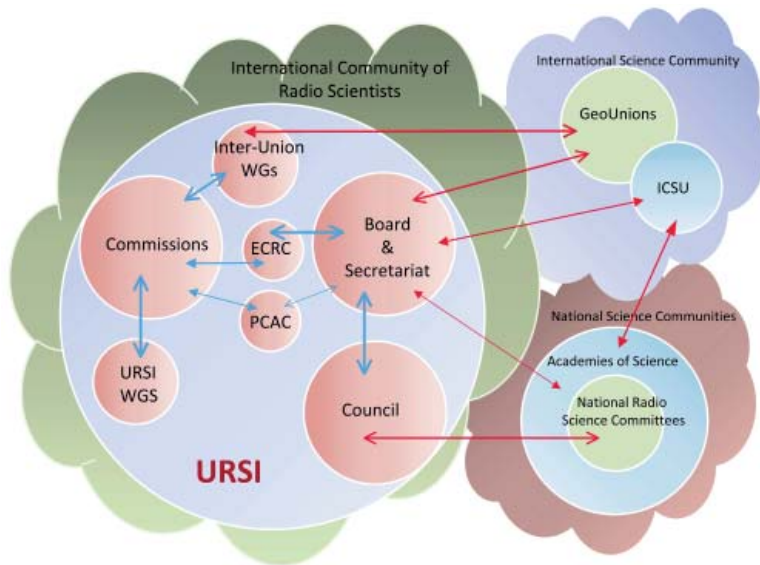

Figure 1. A graphical representation of the various entities associated with URSI.

Between the GASS', and acting on advice provided by Council during the GASS, the Board develops and implements new initiatives and manages the operation of URSI, which includes responding to issues raised in the international scientific community. ICSU (<http://www.icsu.org/>) can raise formal requests for information and support for their initiatives and, where appropriate, the Board provides input. It is extremely hard to feel that these links work effectively. The GeoUnions (<http://icsu-geounions.org/>) are a loose cluster of Unions within ICSU with a common background, and URSI has been more successful working with this group. The prime aim of these links is to extend the influence of URSI into the science community at all levels. Although the Board may consult with the Commission Chairs, currently there is no widely successful mechanism for diffusing these external links throughout URSI.

The implementation of initiatives and the development of effective recommendations for Council rely on the Board having a wide and relevant overview of URSI. The Board is supported in this by two important committees. The Past Chairs Advisory Committee (PCAC) serves to assist the Board in recognizing the development of radio science, and assists in positioning URSI for the future. The second committee is a recent and important initiative. URSI has long had a strong commitment to support Young Scientists attending the GASS, among other activities. However, until recently, there has been no mechanism for drawing directly on younger scientists' knowledge and views of the future. The Early Career Representative Committee (ECRC) has been developed to achieve this end.

At the 2014 GASS, all recognized that in the current modern environment of over-rapid communications provided by the Internet, URSI could not survive with a decision-cycle cadence of three years. While significant initiatives may get implemented over a three-year period, more-frequent meetings – especially meetings based on scientific symposia – are essential for URSI to progress in

the modern era. To this end, AT-RASC has been successfully initiated, and AP-RASC will be supported to a greater degree. Through greater contact between radio scientists, all of the interaction links will be enhanced.

Every December, the *Radio Science Bulletin* publishes the most recent "List of URSI Officials." These are the heart of URSI: these are the people whose time and skills are gifted to ensure that URSI continues into the 21st century and beyond.

Introducing Stefan J. Wijnholds, Associate Editor for the ECR Column

Stefan J. Wijnholds is a System Researcher at the Netherlands Institute for Radio Astronomy (ASTRON). He received his MSc in Astronomy and his MEng in Applied Physics from the University of Groningen, The Netherlands (both *cum laude*) in 2003. He received his PhD in Statistical Signal Processing from the Delft University of Technology, The Netherlands, in 2010. Since 2003, he has been working at ASTRON on the development of phased-array antenna systems for radio astronomy.

His research concentrates on calibration and imaging with astronomical phased-array systems, and system-design optimization for radio-astronomical applications. He has written or contributed to one book chapter, 34 journal papers, and 38 refereed conference contributions. He has organized special sessions at the IEEE International Conference on Acoustics, Speech and Signal Processing (ICASSP) in 2014, and the URSI Atlantic Radio Science Conference (AT-RASC) in 2015. He was a member of the TPC of the European Conference on Antennas and Propagation (EuCAP) in 2015. He is a Senior Member of the IEEE and an URSI Radio Scientist. In 2015, he was elected as Early Career Representative (ECR) for Commission J, and as Chair of the ECR Committee, for URSI.



Giuseppe Pelosi

Department of Information Engineering
University of Florence
Via di S. Marta, 3, 50139 Florence, Italy
E-mail: giuseppe.pelosi@unifi.it

Foreword from the Associate Editor

Recently, there were celebrations of the 150 years since J. C. Maxwell's lecture at the Royal Society of London, and the subsequent publication of the paper, "A Dynamical Theory of the Electromagnetic Field" (*Philosophical Transactions of the Royal Society*, **155**, 1865, pp. 459-512). In his lecture, Maxwell introduced his famous equations for the first time. Several events celebrated this anniversary. Among those at an international level, I wish to cite the special section of the *IEEE Antennas and Propagation Magazine* (**5**, 6, December 2014, pp. 295-316), which I coordinated, titled "A Tribute to James Clerk Maxwell on the 150th Anniversary of His Equations (1864-2014)." Among the papers in that special section was one by E. Agastra

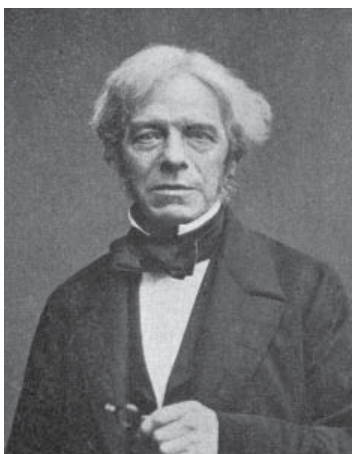

Figure 1a. M. Faraday [Newington Butts, United Kingdom, September 22, 1791 – Hampton Court, United Kingdom, August 25, 1867].



Figure 1b. F. O. Mossotti [Novara, Italy, April 18, 1791 – Pisa, Italy, March 20, 1863].

and S. Selleri, "The Pavers of Maxwell's Pathway to His Equations" (pp. 308-316). This presented an interesting tree of scientists, on a nation-by-nation basis, which preceded Maxwell, and were cited by him. In particular, among the several scientists Maxwell cited, Edmund Taylor Whittaker, renown historian of science who lived between the 19th and 20th centuries, identified three that were the most influential on Maxwell in his development of the displacement current, which was Maxwell's key contribution. These three were Michael Faraday, Ottaviano Fabrizio Mossotti, and William Thomson (Lord Kelvin) (Figure 1) [1].

Much has been written on Michael Faraday and Lord Kelvin. *Radio Science Bulletin* readers can refer to [2, 3].

The Italian, F.,O. Mossotti, is quite unrecognized today, even in Italy. The paper published here in the December issue of the *Radio Science Bulletin*, "The Pavers of Maxwell's Pathway to His Equations: Ottaviano

Fabrizio Mossotti,” written with Stefano Selleri (University of Florence), is dedicated to the life and works of F. O. Mossotti. It carefully reconstructs his published papers.

References

1. E. T. Whittaker, *A History of the Theories of Aether and Electricity*, Dublin, Ireland, Hodges, Friggis & Co., 1910.
2. J. M. Thomas, *Michael Faraday and the Royal Institution: The Genius of Man and Place*, New York, Taylor & Francis, 1991, ISBN 978-0750301459.
3. A. Grey, *Lord Kelvin: An Account of His Scientific Life and Work*, London, J. M. Dent, 1908, republished by Audubon Press, 2008, ISBN 978-1443716628.

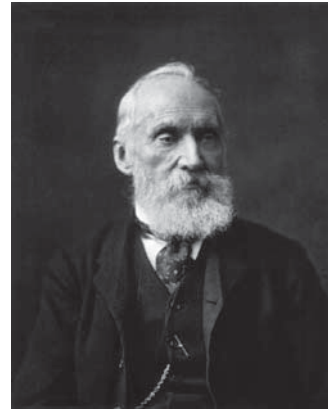

Figure 1c. W. Thomson [Belfast, Ireland, June 26, 1824 – Largs, United Kingdom, December 17, 1907].

The Pavers of Maxwell’s Pathway to His Equations: Ottaviano Fabrizio Mossotti

Giuseppe Pelosi and Stefano Selleri

University of Florence
Via di S. Marta 3, I-50139 Florence, Italy
E-mail: [giuseppe.pelosi, stefano.selleri]@unifi.it

1. Life

Ottaviano-Fabrizio Mossotti (Figure 1) [Novara, Italy, April 18, 1791 – Pisa, Italy, March 20, 1863] was an Italian physicist, son of an engineer, Giovanni, and of Rosa Gola. Little is known about his early studies: his father probably started teaching him at home. The first certain records say he was at the King’s College in his home town in the year 1807-1808, where he was also awarded a prize in “literature, history, and mathematics” [1, 2].

In 1808, he entered the Faculty of Mathematics at the University of Pavia (Figure 2), where he graduated as an “Architect-Engineer” on June 6, 1811. He remained at the university, getting acquainted with the astronomical works of Galilee, Kepler, and Newton, and publishing his first scientific paper in 1913.

He then entered the astronomical observatory, or “Specola,” of Brera in Milan, Italy (Figure 3), a relevant observatory in Italy, which became famous worldwide for the work of Schiaparelli in 1877 [3-5]. In those post-Napoleonic years, Italy, still divided into several small



Figure 1. Ottaviano Fabrizio Mossotti, in an undated portrait, when young, from [1].

states, was the home of revolts, and home to secret societies promoting unification. Mossotti was politically involved,



Figure 2. One of the cloisters of the historical building of the University of Pavia, Italy, where Mossotti studied.

and close to many leaders of unification movements. When several of his friends became imprisoned and he himself was prosecuted, he decided to flee to Switzerland in March, 1823, and then to London in May, 1823. There, he got in contact with many members of the Royal Society, in particular Thomas Young [Milverton, United Kingdom, June 13, 1773 – London, United Kingdom, May 10, 1829] [6][M.30] and John Frederick William Herschel [Slough, United Kingdom, March 7, 1792 – Hawkhurst, United Kingdom, May 11, 1871]. Mossotti eventually himself became a member of the Royal Society in 1826. He then got a teaching appointment at the University of Buenos Aires, so he left London in 1827. In Argentina, he could carry out astronomical observations that were not possible in the northern hemisphere, which he published in the *Proceedings of the Royal Astronomical Society of London*.

He was then able to go back to Italy. Called to the Astronomical Observatory of Bologna 1835, he failed to get the position, due to Austrian government opposition, motivated by his political past. He then was in Turin where, in 1836, he published his fundamental work on dielectric induction [M.26]. This was publicly appreciated by Michael Faraday himself, and was among the bases of J. C. Maxwell's development of the displacement current.

He was later offered (1840) the Chair of Mathematics, Physics, and Celestial Mechanics at the University of Pisa, and was among the founders of the Mathematical School of Pisa. He participated in the 1848 war of independence as Commander of the Pisa University battalion of volunteers, formed by professors and students. After unification, he was nominated Senator of the newborn Kingdom of Italy (1861).

Mossotti died in 1863 after a short illness. He was buried in the monumental cemetery of Pisa, with Angelo Battelli [Macerata Feltria, Pesaro e Urbino, Italy, March 28, 1862 – Pisa, Italy, December 11 1916], physicist, founder of the Italian Society of Physics, and pioneer of radioactivity studies; Antonio Pacinotti [Pisa, Italy, June 17, 1841 – Pisa, Italy March 25, 1912], physicist, who substantially improved the earliest design of the direct-

current electrical generator, or dynamo; and Ulisse Dini [Pisa, Italy, November 14, 1845 – Pisa, Italy, October 28, 1918], mathematician.

2. Achievements and Connections to Maxwell

Early in the 19th century, the concept of dielectrics was still a matter of open research. It was apparent that even if unable to conduct current, they had electrical properties, since, for example, the strength of the attraction between two charges changed if a dielectric was placed between them.

Concerning the nature of electricity, two rival theories were on the floor at the time. One was a one-fluid theory. This had among its first and most notable supporters Benjamin Franklin [Boston, Massachusetts, January 6, 1705 – Philadelphia, Pennsylvania, April 17, 1790], who viewed electrical phenomena as due to a single “electric” fluid, or aether. The amount of fluid at equilibrium made a body uncharged. If the fluid was added or removed – for example, by rubbing – the body became positively or negatively charged (respectively) from the concentration or rarefaction of the fluid. The motion of the same fluid was the electric current. This was opposed by the two-fluid theory, named “vitreous” and “resinous,” developed earlier by Charles François de Cisternay du Fay [Paris, September 14, 1698 – Paris, 16 July 1739]. He explained

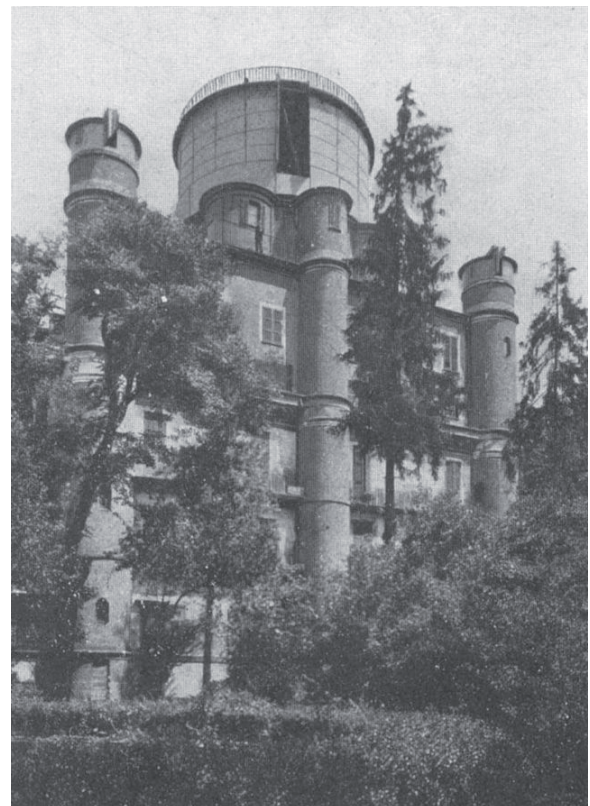

Figure 3. The astronomical observatory, or “specola,” of Brera, in Milan, Italy.

SUR LES FORCES
 QUI RÉGISSENT
LA CONSTITUTION INTÉRIEURE DES CORPS
 APERÇU
 POUR SERVIR À LA DÉTERMINATION
 DE LA CAUSE ET DES LOIS DE L'ACTION MOLÉCULAIRE
 PAR
G. F. MOSSOTTI
 LE DES CHAQUE DE LA SOCIÉTÉ ITALIENNE DES SCIENCES



TURIN
 DE L'IMPRIMERIE ROYALE
 MDCCLXXXVI.

Figure 4a. The cover of the 1836 Mossotti paper [M.26] where the single-fluid displacement theory of dielectrics was discussed.

his observations on electrification by means of “vitreous” and “resinous” kinds of electricity. The first theory was followed in England, Germany, and Italy, while the second was mainly in France [7].

Mossotti’s 1836 paper [M.26] (Figure 4) was hence written in the context of the one-fluid theory, and was opposed to a similar work of Poisson on magnetism [8, 9]. Mossotti recognized how the results by Poisson with the two “vitreous” and “resinous” fluids could be explained by a single “electric” fluid, by considering the action of the “vitreous fluid” to be equivalent to a condensation of the “electric” fluid, and the action of the “resinous” fluid to be the rarefaction of the “electric” fluid [M.26]. In this context, is very important to note for the following development by Faraday and Maxwell that Mossotti focused on the *movement* of such a fluid, not on the mere action due to the presence of a fluid.

In Mossotti’s work, the equilibrium was hence reached with the electric forces of the matter (unmovable) and the “electric” fluid (movable). Mossotti then mathematically developed this concept. He considered the molecules of the matter as unmovable, isolated, spherical objects, within a homogeneous “electric” fluid, or aether. Among the molecules there was a repulsion force, which at equilibrium was nullified by the attractive force between the molecules and the aether. In this way, Mossotti explained why solids cannot be compressed (the repulsion force between molecules became stronger if molecules got closer) or expanded (the attractive force of the aether opposed the molecular separation).

cipe on substitue le suivant: « Si plusieurs corps conducteurs » électriques sont mis en présence les uns des autres et qu'ils » parviennent à un état permanent, il faudra, dans cet état que » la résultante des actions des couches du fluide électrique qui les » recouvrent, et des couches extérieures de la matière, qui ne » sont pas neutralisées, sur le fluide électrique, dans un point pris » quelque part que ce soit dans l'intérieur d'un corps soit nulle; » sans quoi, le fluide électrique, qui réside dans le point, serait » déplacé, contre la supposition que l'on a fait de l'état de » permanence »; et si l'on interprète d'une manière analogue les dénominations littérales que M. Poisson a employé dans ses équations, tous ses résultats seront également vrais pour l'hypothèse de FRANKLIN. En général l'action du fluide électrique condensé tiendra lieu de l'action du fluide vitreux, et l'action que déploie la matière à mesure qu'elle est dépourvue d'une quantité de son fluide électrique, tiendra lieu de l'action du fluide résineux. Une seule circonstance met de la différence entre l'hypothèse de DUFAY ou COULOMB et celle de FRANKLIN; elle consiste en ce, que selon l'une, les deux fluides sont mobiles dans les corps, tandis que selon l'autre le fluide électrique seulement peut se mouvoir, et non pas la matière; mais comme pour l'équilibre il ne faut que tenir compte de la position relative, la mobilité du fluide électrique est suffisante pour qu'il s'établisse de la même manière.

ERIVUS, qui a réduit sous la forme d'une théorie mathématique l'hypothèse de FRANKLIN, a remarqué le premier, que si la condition de l'équilibre des fluides électriques des deux corps à l'état naturel est; que l'attraction de la matière et la répulsion du fluide du premier sur le fluide du second soient égales, et réciproquement, il n'y a en jeu que trois forces dont deux d'attraction et une seule de répulsion. En effet chacun des deux corps exerce par sa matière une force d'attraction sur le fluide de l'autre, tandis que la répulsion mutuelle des deux fluides ne constitue qu'une seule force égale à chacune des deux premières. Si donc, avec l'équilibre des fluides,

Figure 4b. Page 7 of the paper in Figure 4a.

This paper by Mossotti was appreciated by Michael Faraday [Southwark, UK, September 22, 1791 – Hampton Court, UK, August 25, 1867]. Faraday supposed that in an impressed electric field, a change charge was exerted in the distribution of molecules and “electric” fluid [7, 10]. However, the model by Mossotti was much more detailed than Faraday’s [11]. These concepts were later very clearly stated by Mossotti, who give an analytic solution to the problem, explicitly speaking of “polarization of the molecules” [M.48].

Mossotti’s contribution was also recognized by James Clerk Maxwell [12-14] (Figures 5 and 6), as well as by early writers of electromagnetic history. For example, Edmund Taylor Whittaker [Southport, UK, October 24, 1873 – Edinburgh, UK, March 24, 1956] (Figure 5), British mathematician and physics historian, wrote [7] (Figure 7):

The principle which is peculiar to Maxwell’s theory must now be introduced. Currents of conduction are not the only kind of currents; even in the older theory of Faraday, Thomson, and Mossotti, it had been assumed that electric charges are set in motion in the particles of a dielectric when the dielectric is subjected to an electric field; and the predecessors of Maxwell would not have refused to admit that the motion of these charges is in some sense a current.

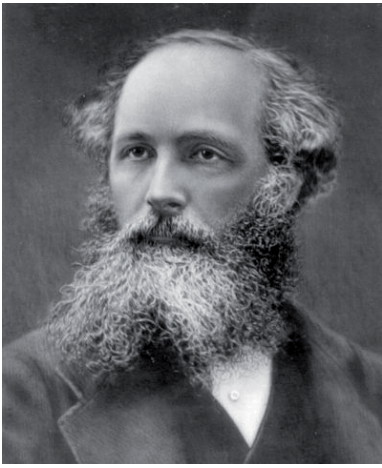

Figure 5a. J. C. Maxwell.



Figure 5b. E. T. Whittaker.



Figure 5c. J. H. Poincaré.

Poincaré [Nancy, France, April 29, 1854–Paris, France, July 17, 1912] (Figure 5), French mathematician and physicist, wrote [15] (Figure 8):

It is probable that it is the concept of Poisson and Mossotti on the nature of dielectrics which led Maxwell to his theory. He says to have developed it since Faraday's works, and to have done nothing else than to convert to mathematical formulas the words of the renowned Physicist, but Faraday did adopt Mossotti's Ideas (see Experimental Researches, Faraday, Ser. XIV, §1679.

Mossotti's subsequent, more detailed, 1846 manuscript, published in 1850 [M.48] (Figure 9) better presented his ideas on polarization. These ideas were later mathematically formalized by Rudolph Clausius [Koszalin, Poland, January 2, 1822–Bonn, Germany, August 24, 1888]

introduced when any difficulty occurs. Thus, Mossotti has deduced the mathematical theory of dielectrics from the ordinary theory of attraction merely by giving an electric instead of a magnetic interpretation to the symbols in the investigation by which Poisson has deduced the theory of magnetic induction from the theory of magnetic fluids. He assumes the existence within the dielectric of small conducting elements, capable of having their opposite surfaces oppositely electrified by induction, but not capable of losing or gaining electricity on the whole, owing to their being insulated from each other by a non-conducting medium. This theory of dielectrics is consistent with the laws of electricity, and may be actually true. If it is true, the specific inductive capacity of a dielectric may be greater, but cannot be less, than that of a vacuum. No instance has yet been found of a dielectric having an inductive capacity less than that of a vacuum, but if such should be discovered, Mossotti's physical theory must be abandoned, although his formulae would all remain exact, and would only require us to alter the sign of a coefficient.

Figure 6. Part of page 70 in [14], where Maxwell not only acknowledged the importance of Mossotti's analytic development, but stated that in Mossotti's theory, no material can have a permittivity smaller than that of empty space.

[16] (Figure 10). Indeed, as already said, the original papers by Mossotti were based on an ether concept typical of his epoch, and are hence difficult to follow for the modern reader. Clausius' later approach revised Mossotti's work in a way much easier to follow for the modern reader [11, 17]. The Clausius-Mossotti formula is

$$\frac{\varepsilon - \varepsilon_0}{\varepsilon + 2\varepsilon_0} = \frac{4\pi N_A \alpha \rho_m}{3 M}, \quad (1)$$

with ε and ε_0 being the permittivity of the dielectric and of free space, respectively; N_A is Avogadro's number; α is the polarizability of the dielectric, that is, the ratio of the induced dipole moment of an atom or molecule to the electric field that produces this dipole moment; ρ_m the dielectric density; and M is its molecular mass.

286

Maxwell.

from which equation it is evident that ψ represents the electrostatic potential.

The principle which is peculiar to Maxwell's theory must now be introduced. Currents of conduction are not the only kind of currents; even in the older theory of Faraday, Thomson, and Mossotti, it had been assumed that electric charges are set in motion in the particles of a dielectric when the dielectric is subjected to an electric field; and the predecessors of Maxwell would not have refused to admit that the motion of these charges is in some sense a current. Suppose, then, that \mathbf{S} denotes the total current which is capable of generating a magnetic field: since the integral of the magnetic force round any curve is proportional to the electric current which flows through the gap enclosed by the curve, we have in suitable units

Figure 7. The top of page 286 in [7], where Whittaker acknowledged Faraday, Thompson, and Mossotti among the predecessors of Maxwell who studied dielectric polarization.

Il est probable que c'est la conception de Poisson et Mossotti sur la nature des diélectriques qui a conduit Maxwell à sa théorie. Il dit l'avoir déduite des travaux de Faraday et n'avoir fait que traduire sous une forme mathématique les vues de ce célèbre physicien ; or, Faraday avait adopté les idées de Mossotti (Cf. Experimental Researches, Faraday, série XIV, § 1679). Ajoutons que, ainsi que nous le verrons bientôt, l'intensité des courants de déplacement n'a pas la même valeur dans la théorie de Poisson et dans celle de Maxwell. Nous montrerons cependant comment on peut faire concorder les deux théories.

The left-hand term in Equation (1) is known as the Clausius-Mossotti factor. When extended to the more general case of a generic dielectric sphere, p , embedded in a homogeneous medium, m , this is

$$K(\omega) = \frac{\bar{\epsilon}_p - \bar{\epsilon}_m}{\bar{\epsilon}_p + 2\bar{\epsilon}_m}, \quad (2)$$

with $\bar{\epsilon} = \epsilon - j\sigma/\omega$.

Indeed, this is the first appearance of the concept of an effective homogeneous medium in the theory of heterogeneous solids. As pointed out by many authors [11, 18], Mossotti's paper [M.48] does not explicitly contain the formula for the effective dielectric constant, while



Figure 9a. The cover of the 1946 Mossotti paper, published in 1950 [M.48].

Figure 8. Page 36, proposition 44, in [15], where Poincaré affirmed that Maxwell's displacement-current idea originated from Poisson's and Mossotti's ideas on dielectric polarization.

Clausius' book does (Figure 11). That is why Hendrik Antoon Lorentz [Arnhem, NL, July 18, 1853 – Haarlem, NL, February 4, 1928] (Figure 10) attributed the formula to Clausius and Mossotti [19], even if Clausius did not cite Mossotti in his book [16].

Mossotti's deep understanding of dielectrics led him to a second achievement still bearing his name, the Clairaut-Mossotti doublet. This was an aplanatic cemented doublet lens, able to correct for axial chromatism, spherical aberration, and coma [20]. Alexis Claude Clairaut [Paris, France, May 13, 1713 – Paris, France, May 17, 1765], an astronomer, had developed a theory of doublet lenses, that is, lenses composed of two cemented lenses of different

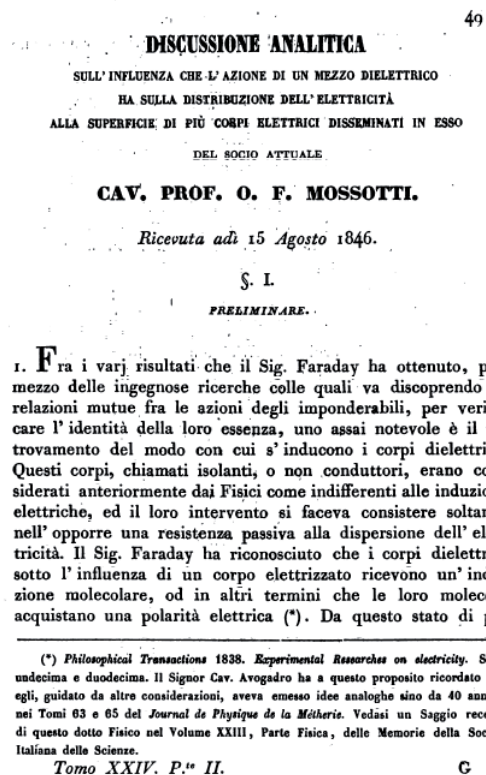

Figure 9b. The first page of the paper in Figure 9a.

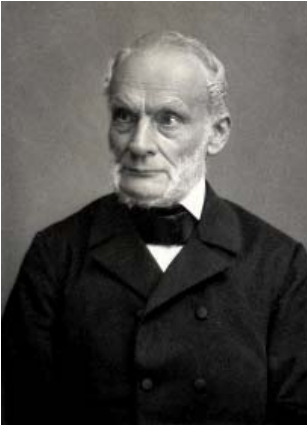

Figure 10a. Rudolph Clausius.

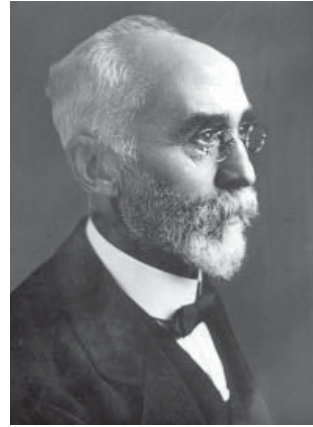

Figure 10b. Hendrik Antoon Lorentz.

materials and appropriate shapes to control spherical and chromatic aberration in the period of 1756-1762. Mossotti solved the fifth-order equation by Clairaut, finding three real roots, of which one was of practical interest [M.57, M.58] (Figure 12).

Mossotti was not highly committed to publishing his results. As Enrico Betti [Pistoia, Italy, October 21, 1823 – Soiana, Pisa, Italy, August 11, 1892], great mathematician

and student of Mossotti, stated in his obituary of Mossotti [21], Mossotti left many ideas on scratch paper, unfinished publications, and even complete papers never submitted to a journal. He even thought of using the inverse function of elliptical integrals of the first kind, years before Niels Henrik [Finnøy, Norway, August 5, 1802 – Froland, Norway, April 6, 1829] and Carl Gustav Jacob Jacobi [Potsdam, Germany, December 10, 1804 – Berlin, Germany, February 18, 1851], but left all of this on scratch paper [21]. A complete list of Mossotti’s published papers can be found below, while a collection of published and unpublished papers and letters can be found in [23].

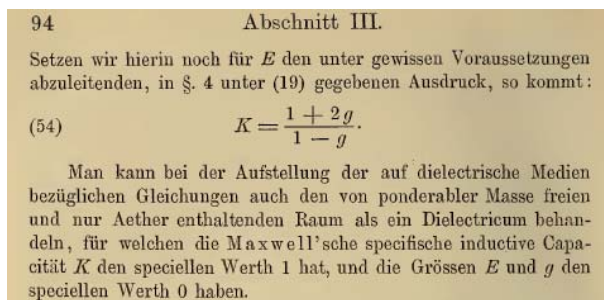

Figure 11. The Clausius-Mossotti formula in Clausius's book (written as the inverse of what we use today) [16].

3. Bibliography

The bibliography of Ottaviano Fabrizio Mossotti reported here below was chiefly extracted from 0, integrated, and with translations of the titles. Please note that in cases where a double year is present, the first year, usually in italics, is part of the title of the publication, while the second year, in roman type, is the publication year. For example, this is the case of the *Ephemeris*, which was published the year before that to which it refers.

M.1. O.F. Mossotti, “Nota sopra un problema nella Teorica dell’Ariete Idraulico [Note above a problem of the Water

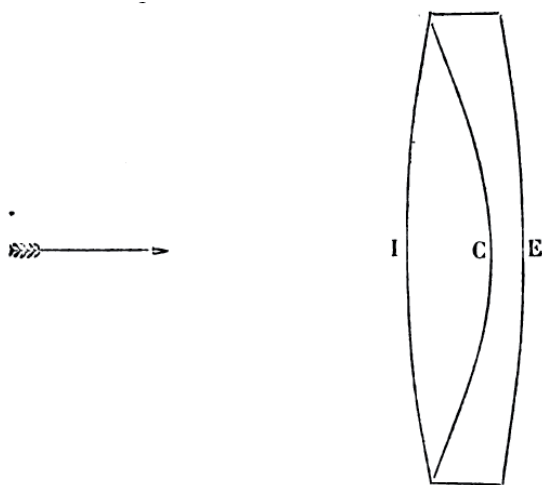

Figure 12a. Mossotti's drawing for a doublet achromatic, aspherical lens, from [M.58].

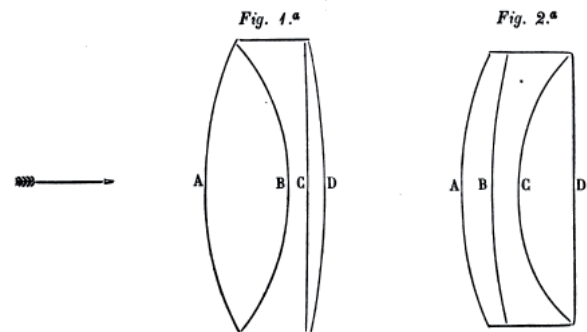

Figure 12b. Mossotti's drawing for two triplet achromatic, aspherical lenses, from [M.58].

Hammer],” in Cav. Brunacci, *Trattato dell’Ariete Idraulico*, Milano, Stamperia Reale, 1813, pp. 70-73.

M.2. O. F. Mossotti, “Del movimento di un fluido elastico che sorte da un vaso e della pressione che fa sulle pareti dello stesso [On the movement of an elastic fluid that exit from a jar and the pressure on the walls of the same],” *Memorie della Società Italiana delle Scienze*, **XVII**, 1816, pp. 16-72.

M.3. O. F. Mossotti, “Nuova analisi del problema di determinare le orbite dei corpi celesti [New analysis of the problem of determining the orbits of celestial bodies],” appendix to *Effemeridi astronomiche di Milano per l’anno 1817*, 1816.

M.4. O. F. Mossotti, “Nuova analisi del problema di determinare le orbite dei corpi celesti. Parte Seconda [New analysis of the problem of determining the orbits of celestial bodies. Part two],” appendix to *Effemeridi astronomiche di Milano per l’anno 1818, 1817*.

M.5. O. F. Mossotti, “Supplimento alla nuova analisi del problema di determinare le orbite dei corpi celesti [Supplement to the new analysis of the problem of determining the orbits of celestial bodies],” appendix to *Effemeridi astronomiche di Milano per l’anno 1819*, 1819.

M.6. O. F. Mossotti, “Biblioteca scelta di opere italiane antiche e moderne. Notizie astronomiche adattate all’uso comune di Antonio Cagnoli ecc. – Un volume con tre tavole in rame e ritratto. Milano per Giionni Sllvestri, 1818 [Selected Bibliography of Italian works, ancient and modern. News astronomical adapted for common usage by Antonio Cagnoli etc. – A volume with three panels in copper and portrait. Giionni Sllvestri, Milan, 1818],” *Il Conciliatore*, No. 59, March 25, 1819, pp. 237 [book review].

M.7. O. F. Mossotti, “Delle Comete [On Comets],” *Il Conciliatore*, No. 93, July 22, 1819, pp. 375.

M.8. O. F. Mossotti, “Della inalveazione del torrente Redefosso. Saggio storico-idraulico [Canalization of the river Redefosso. Historical-hydraulic survey],” *Il Conciliatore*, No. 110, September 19, 1819, pp. 443.

M.9. O. F. Mossotti, “Memorie e lettere inedite finora, o disperse, di Galileo Galilei, ordinate ed illustrate con annotazioni daI Cav. Giambattista Venturi. Parte Prima, portante in fronte una copia fedele del ritratto del Galileo inciso da F. Villamena nel 1613. Modena 1818 [Memoirs and letters unpublished or lost so far, by Galileo Galilei, ordered and illustrated with annotations by Cav. Giambattista Venturi. Part One, bearing the face a true copy of the portrait of Galileo engraved by F. Villamena in 1613. Modena 1818],” *Il Conciliatore*, No 114, October 3, 1819, p.459.

M.10. O. F. Mossotti, “Formole per determinare gli assi del Sole supposto uno sferoide ellittico con applicazioni [Formulas to determine the axes of the Sun assumed as an elliptical spheroid, with applications],” appendix to

Effemeridi astronomiche di Milano per l’anno bisestile 1820, 1819, pp. 65-90.

M.11. O. F. Mossotti, “Sul movimento di un elice elastica che si scatta [On the movement of an elastic helix released],” *Memorie della Società Italiana delle Scienze*, **XVIII**, 1820, pp. 243-268.

M.12. O. F. Mossotti, “Sulle figure e sul tempo della rotazione del Sole [The ways and the time of rotation of the Sun],” appendix to *Effemeridi astronomiche di Milano per l’anno 1821*, 1820, pp. 41,78.

M.13. O. F. Mossotti, “Sul moto di un aerostata ellissoidale [On the motion of an ellipsoidal balloon],” *Giornale di fisica, chimica, storia naturale, medicina ed arti dei professori Pietro Configliachi e Gaspare Brugnatelli*, Decade II, **IV**, No. 6, 1821, pp. 415-428.

M.14. O. F. Mossotti, “Opposizione di Giove nell’anno 1820 osservata al quadrante murale [Opposition of Jupiter in the year 1820 observed at the *Quadrantis Muralis*],” Appendix to *Effemeridi astronomiche di Milano per l’anno 1822, 1821*, pp. 37-43.

M.15. O. F. Mossotti, “Attrazione e masse variabili delle Comete [Attraction and variable masses of Comets],” [Letter to Franz Xaver von Zach] *Correspondance astronomique, géographique, hydrographique et statistique du Baron de Zach*, **8**, 1823, pp. 81-83.

M.16. O. F. Mossotti, “Sur un novel instrument pour prendre les distances [On a novel instrument to measure the distances],” (Letter to Franz Xaver von Zach) *Correspondance astronomique, géographique, hydrographique et statistique du Baron de Zach*, 1823, **8**, pp. 346-359.

M.17. O. F. Mossotti, “Sur le calcul des distances des astres [The calculation of the distances of the stars],” (Letter to Franz Xaver von Zach) *Correspondance astronomique, géographique, hydrographique et statistique du Baron de Zach*, **9**, 1823, pp. 384-389.

M.18. O. F. Mossotti, “Sul moto dell’acqua nei canali [On the motion of the water in the canals],” *Memorie della Società Italiana delle Scienze*, **XIX**, 1823, pp. 616-658.

M.19. O. F. Mossotti, “On the Variation in the Mean Motion of the Comet of Encke, produced by the resistance on an ether,” *Memoirs of the Astronomical Society of London*, **II**, Part I, 1826, pp. 55-62.

M.20. O. F. Mossotti, “Observations of the transit of Mercury over the Sun’s disk in May 1832,” *Monthly Notices of the Royal Astronomical Society*, **III**, 1834, p. 37-38.

M.21. O. F. Mossotti, “Computations and deductions relative to the transit of Mercury over the Sun’s disc on 5th May 1932,” *Monthly Notices of the Royal Astronomical Society*, **III**, 1835, p. 131.

- M.22. O. F. Mossotti, "Solar Eclipse of January 20, 1833 observed at Buenos Ayres," *Memoirs of the Astronomical Society of London*, **VIII**, 1835, p. 224.
- M.23. O. F. Mossotti, "Places of Encke's Comet, from Observations at Buenos Aires," *Memoirs of the Astronomical Society of London*, **VIII**, 1835, p. 224-249.
- M.24. O. F. Mossotti, "Transit of Mercury, May 5, 1832, observed at Buenos Aires. In a Letter to Mr. Baily, dated May 1, 1833," *Memoirs of the Astronomical Society of London*, **VIII**, 1835, p. 268-270.
- M.25. O. F. Mossotti, "Météorologie—Mémoire sur le climat de la ville de Buenos Aires [Meteorology—Memoire on the climate of the city of Buenos Aires]," *Comptes Rendus des Séances de l'Académie des Sciences, Paris*, **I**, 1835, p. 283.
- M.26. O. F. Mossotti, *Sur les forces qui régissent la constitution intérieure des corps, aperçu pour servir à la détermination de la cause et des lois de l'action moléculaire [On the forces that govern the inner constitution of bodies, to serve for the determination of the cause and the laws of molecular action]*, Imprimerie Royale, Turin, Italy, 1836.
- M.27. O. F. Mossotti, "Formola per rappresentare la tensione del vapor acqueo [Equation representing the tension of aqueous vapor]," *Memorie della Società Italiana delle Scienze*, **XXI**, 1837, pp. 335-345.
- M.28. O. F. Mossotti, "Sulla costituzione del sistema stellare di cui fa parte il Sole. Discorso pronunziato il primo di ottobre all'apertura del corso scolastico dell'anno 1839-1840 nell'Università Jonia [On the constitution of the star system to which the Sun belongs. Speech pronounced at the beginning of October for the opening of school year 1839-1840 of the Jonia University]," *Biblioteca Italiana*, **XCVI**, 1839, pp. 263-275.
- M.29. O. F. Mossotti, "Dell'azione delle forze molecolari nella produzione dei fenomeni di capillarità [On the action of molecular forces in the production of the phenomena of capillarity]," *Biblioteca Italiana*, **XCVIII**, 1840, pp. 63-80.
- M.30. O. F. Mossotti, "Nota sopra un fenomeno capillare osservato dal dott. Young [Note on a capillary phenomenon observed by Dr. Young]," *Biblioteca Italiana*, **XCVIII**, 1840, pp. 365-375.
- M.31. O. F. Mossotti, "Sul principio che la riflessione e rifrazione su di una superficie unifrangente polarizzano nelle due porzioni in cui vien diviso il raggio incidente due quantità di luce uguali, rispettivamente in due piani ortogonali fra loro [On the principle that the reflection and refraction on a singly-refractive surface polarize the two portions into which the incident ray is divided into two equal quantities of light, in two planes orthogonal to each other]," *Giornale Toscano di scienze mediche, fisiche e naturali*, **I**, 1841, pp. 330-337.
- M.32. O. F. Mossotti, "Sulla causa della dispersione della luce nel sistema delle ondulazioni. Estratto letto nella seduta dei 22 settembre 1841 del Congresso di Firenze [On the dispersion of light in the system of undulations. Excerpt read in the session of September 22, 1841 of the Congress of Florence]," *Giornale Toscano di scienze mediche, fisiche e naturali*, **I**, 1841, pp. 337-341.
- M.33. O. F. Mossotti, "Rapporto relativo alla Memoria del Prof. Barsotti sui coefficienti della formola Newtoniana del Binomio [Report on the memoire of Prof. Barsotti on the coefficients of the formula of Newton's Binomial]," *Atti della Terza Riunione degli Scienziati Italiani tenuta in Firenze nel Settembre del 1841*, 1841, pp. 223-225.
- M.34. O. F. Mossotti, "Rapporto relativo ad un Telescopio Newtoniano costruito dal prof. Gonnella [Report on a Newtonian telescope built by prof. Gonnella]," *Atti della Terza Riunione degli Scienziati Italiani tenuta in Firenze nel Settembre del 1841*, 1841, pp. 261-262.
- M.35. O. F. Mossotti, "Prolusione letta all'apertura del corso di Fisica Matematica e Meccanica Celeste nell'Università di Pisa dal Professor O. F. Mossotti il 5 Novembre 1841 [Inaugural speech read at the opening of the course of Physics, Mathematics and Celestial Mechanics at the University of Pisa by Professor O. F. Mossotti November 5, 1841]," printed without date or other information, booklet of 18 pages.
- M.36. O. F. Mossotti, *Lezioni Elementari di Fisica Matematica [Elementary Lessons of Mathematical Physics]*, G. Piatti, Firenze, Vol. I printed 1843, Vol. II printed 1845.
- M.37. O. F. Mossotti, "Discussione spettante alla teorica delle forze molecolari [Theoretical discussion on the molecular forces]," *Atti della Quarta Riunione degli Scienziati tenuta in Padova nel settembre 1842*, 1843, pp. 481-483.
- M.38. O. F. Mossotti, "Su di una proposta fatta dal Prof. Giuseppe Belli alla Seconda Riunione degli Scienziati italiani e pubblicata nel 100° volume della Biblioteca Italiana [On a proposal made by Prof. Giuseppe Belli at the Second Meeting of Italian scientists and published in the 100th volume of the Italian Library]," *Il Cimento, Giornale di Fisica, Chimica e Storia Naturale*, year II, 1844, pp. 24-32.
- M.39. O. F. Mossotti, "Comunicazione fatta alla VI riunione dei Cultori Italiani delle Scienze Naturali tenuta in Milano: 1° Riflessioni intorno alla forza epipolica, 2° Deduzione delle formole della doppia rifrazione di Fresnel dalle equazioni generali del movimento dell'etere disseminato nei corpi cristallizzati [Communication made to the sixth meeting of the Italian Scholars of Natural Sciences held in Milan: 1 Reflections around the epiploic strength, 2nd Deduction of formulas for Fresnel double refraction from the general equations of motion of the ether permeating crystallized bodies]," *Il Cimento, Giornale di Fisica, Chimica e Storia Naturale*, year II, 1844, pp. 429-437.

- M.40. O. F. Mossotti, "Illustrazione di un passo del canto IX del Purgatorio [On a passage of the Canto IX of Purgatory]," *Politecnico*, **VII**, 1845.
- M.41. O. F. Mossotti *et al.*, "Rapporto sulle esperienze eseguite dal Prof. Magrini in relazione a quelle proposte dal Cav. Matteucci sulla conducibilità della terra per le correnti elettriche [Report on the experiences made by Prof. Magrini in relation to those proposed by Cav. Matteucci on the conductivity of the earth for the electrical currents]," *Atti della Sesta Riunione degli Scienziati Italiani tenuta in Milano nel Settembre del 1844*, 1845, pp. 96-105.
- M.42. O. F. Mossotti, "Sulle proprietà degli spettri formati dai reticoli, ed analisi della luce che somministrano [On the properties of the spectrum formed by gratings, and analysis of light that they administer]," *Annali delle Università Toscane*, Part II, Vol. I, 1845, pp. 181-204.
- M.43. O. F. Mossotti, "Comunicazione sopra alcuni argomenti d'acustica e d'ottica fisica fatta alla VII riunione Italiana dei cultori delle scienze naturali Communication on certain topics of acoustic and physical optics physics made at the seventh meeting of the Italian natural scientists," *Il Cimento, Giornale di Fisica, Chimica e Storia Naturale*, year IV, 1846, pp. 97-106.
- [M.44. O. F. Mossotti, "Considerazioni sulle forze di capillarità e coesione dei liquidi relative alle recenti esperienze dei Sigg. Henry, Donny ed Hager [Considerations on the capillary and cohesion forces of a liquid relative to the recent experiences of Mr. Henry, Donny and Hager]," *Il Cimento, Giornale di Fisica, Chimica e Storia Naturale*, year IV, 1846, pp. 439-456. *Atti della Settima Adunanza degli Scienziati Italiani tenuta in Napoli dal 20 Settembre a' 5 di Ottobre del 1845*, 1846, pp. 1079-1081.
- M.45. O. F. Mossotti, "Recherches Théoriques sur l'induction électro-statique, envisagée d'après les idées de Faraday [Theoretical research on the electro-static induction, stemmed by Faraday's ideas]," *Supplément à la Bibliothèque Universelle de Genève, Archives des sciences physiques et naturelles*, **VI**, 1847, pp. 193-198.
- M.46. O. F. Mossotti, "Comunicazione all'VIII Adunanza Italiana dei cultori di scienze naturali [Communication at the eighth Gathering of Italian scholars of natural sciences]," *Il Cimento, Giornale di Fisica, Chimica e Storia Naturale*, year V, 1847, pp. 143-155.
- M.47. O. F. Mossotti, "Parole di congedo pronunciate in Genova alla Sezione di Fisica e Matematica della VIII Riunione degli Scienziati Italiani [Parting words spoken in the Section of Physics and Mathematics of Genova, at the VIII Meeting of Italian Scientists]," *Atti della Ottava Riunione degli Scienziati Italiani tenuta in Genova dal 14 al 29 Settembre 1846*, 1847, p. 311.
- M.48. O. F. Mossotti, "Discussione analitica sull'influenza che l'azione di un mezzo dielettrico ha sulla distribuzione dell'elettricità alla superficie di più corpi elettrici disseminati in esso [Analytical discussion on the influence that the action of a dielectric medium has on the surface distribution of electricity of several electric bodies scattered in it]," *Memorie della Società Italiana delle Scienze in Modena*, **XXIV**, Part II, 1950, pp. 49-74.
- M.49. O. F. Mossotti, "Sulla riduzione degli angoli fatti dagli archi geodetici formanti un piccolo triangolo agli archi fatti dalle loro corde [On the reduction of the angles made by the geodetic arcs forming a small triangle to the arches made from their chords]," *Annali di Scienze matematiche e fisiche compilati da Barnaba Toriolini, I*, 1950, pp. 387-398.
- M.50. O. F. Mossotti, "Soluzione analitica del problema delle oscillazioni del pendolo avuto riguardo alla rotazione della terra. Squarcio di lettera (18.IV.1851) al P. Serpieri, [Analytical solution of the problem of the oscillations of the pendulum with regard to the rotation of the earth. Part of a letter (18.IV.1851) to P. Serpieri]" *Annali di Scienze matematiche e fisiche compilati da Barnaba Toriolini, II*, 1951, pp. 232-236.
- M.51. O. F. Mossotti, "Sull'analogia delle funzioni circolari ed iperboliche, e sulla sostituzione delle une alle altre per trasformare le quantità che si presentano sotto aspetto immaginario [On the analogy of the circular and hyperbolic functions, and on their mutual replacement to process the quantities which are imaginary in aspect]," *Annali di Scienze matematiche e fisiche compilati da Barnaba Toriolini, Vol. II*, 1951, pp. 474-488.
- M.52. O. F. Mossotti, "Lettera del prof. Mossotti al compilatore (sul pendolo di Foucault) [Letter of prof. Mossotti compiler (on the Foucault pendulum)]," *Annali di Scienze matematiche e fisiche compilati da Barnaba Toriolini, IV*, 1953, pp. 135-140.
- M.53. O. F. Mossotti, *Lezioni di Meccanica Razionale [Lessons of Analytical Mechanics]*, printed without cover page and date, but from Mossotti's correspondence should have been printed in 1853.
- M.54. O. F. Mossotti, "Sulle macchie del disco solare [On spots on the Sun's disk]," *Il Nuovo Cimento, Giornale di Fisica, Chimica e delle loro applicazioni alla medicina, alla farmacia ed alle arti industriali, I*, 1855, pp. 105-117.
- M.55. O. F. Mossotti, "Nota all'articolo «Della Scintillazione delle Stelle, Considerazioni del Dottor G.B. Donati» [note to paper «Scintillation of the Stars, considerations of Dr. GB Donati»]," *Il Nuovo Cimento, Giornale di Fisica, Chimica e delle loro applicazioni alla medicina, alla farmacia ed alle arti industriali, II*, 1855, pp. 344-351.
- M.56. O. F. Mossotti, "On the calculation of an observed Eclipse or occultation of a star," *Report of the twenty-fifth meeting of the British Association for the advancement of science; held at Glasgow in September 1855*, 1856, pp. 26-28.

M.57. O. F. Mossotti, “Nuova teoria degli strumenti ottici [New theory of optical instruments, first part],” *Annali delle Università Toscane*, Part. II, **IV**, 1955, pp. 39-164.

M.58. O. F. Mossotti, “Nuova teoria degli strumenti ottici [New theory of optical instruments, second part],” *Annali delle Università Toscane*, Part. II, **V**, 1858, pp.7-91.

M.59. O. F. Mossotti, “On the distribution of the orbits of Comets in Space,” *Report of the twenty-seventh meeting of the British Association for the advancement of science; held at Dublin in August and September 1857*, 1858, pp. 23-24.

M.60. O. F. Mossotti, “Proprietà dei centri coniugati principali e dei piani principali coniugati, dedotte dalla considerazione degli assi dei pennelli luminosi, ed applicazioni di esse al calcolo degli stromenti ottici composti di più lenti delle cui grossezze si debba tener conto [Properties of conjugated main centers and main conjugated main planes, deducted from the consideration of the axes of light beams, and applications of them to calculate instruments comprising several optical lenses whose thicknesses should be taken into account],” *Annali di Matematica pura ed applicata pubblicati da Barnaba Toriolini*, **I**, 1858, pp. 265-277.

M.61. O. F. Mossotti, “Illustrazione di un passo del Canto XXVII del paradiso [Explanation of a passage from Canto XXVII of paradise],” *Rivista Italiana di scienze, lettere, arti con le effemeridi della pubblica istruzione*, year II, No. 53, September 23, 1861.

M.62. O. F. Mossotti, “Azione dei Parafulmini [Functioning of lightning protections],” *Il Nuovo Cimento, Giornale di Fisica, Chimica e storia naturale*, year VIII, **XVI**, 1862, pp. 74-79.

M.63. O. F. Mossotti, “Azione reciproca che si esercita fra due atomi sferici, secondo la retta congiungente i loro centri di gravità [Reciprocal action which is exerted between two spherical atoms, according to the straight line joining their centers of gravity],” in G. Codazza “Considerazioni e studi analitici sul principio della correlazione delle azioni fisiche e dinamiche [Considerations and analytic studies on the principle of correlation of physical actions and dynamics],” *Atti del Reale Istituto Lombardo di Scienze, Lettere e Arti*, **III**, 1863, pp. 176-178.

M.64. O. F. Mossotti, “Teorica ed applicazioni delle funzioni circolari ed iperboliche [Theory and applications of the circular and hyperbolic functions]” in A. Forti, “Tavole dei Logaritmi delle funzioni circolari ed iperboliche [Tables of logarithms of the circular and hyperbolic functions],” *Annali delle Università Toscane*, **VI**, 1863, pp. 7-26.

M.65. O. F. Mossotti, “Sulla rifrazione di una supposta atmosfera lunare [On the refraction of a supposed lunar atmosphere],” *Annali di Matematica pura ed applicata pubblicati da Barnaba Toriolini*, **V**, 1863, pp. 102-105 [posthumous].

M.66. O. F. Mossotti, “Lettere due ad Alessandro Torri in proposito di un passo controverso del c. IX del Purgatorio [Two letters to Alexander Towers about a controversial part of c. IX of the Purgatory] (November 2, 1846 and July 9, 1847),” *Giornale del centenario di Dante Alighieri*, No. 16, July 10, 1864 [posthumous].

M.67. O. F. Mossotti, “Intorno ad un passo della Divina Commedia di Dante Alighieri, Lettera del prof. O. F. M. a B. Boncompagni seguita da una nota intorno a questa lettera [On one part of the Divine Comedy by Dante Alighieri, Letter of prof. O. F. M. B. Boncompagni followed by a note about this letter] (July 9, 1847),” *Atti dell’Accademia Pontificia de’Nuovi Lincei*, Year XVIII, **XVIII**, 1864-1865, Sess. VI, May 7, 1865 [posthumous].

M.68. O. F. Mossotti, “Sopra la determinazione delle orbite dei corpi celesti per mezzo di tre osservazioni [On the determination of the orbits of the celestial bodies by means of three observations],” *Annali delle Università Toscane*, Part II, **VIII**, 1866, pp. 45-88.

3.1 References

1. M. Nagari, *Ottaviano Fabrizio Mossotti*, Istituto per la Storia del Risorgimento, Novara, 1989.
2. L. Liberti, *Ottaviano Fabrizio Mossotti: The Youth Years (1791-1823)*, Bachelor of Science thesis, Imperial College, London 1995.
3. C. Flamation, *La Planète Mars [The Planet Mars]*, Gauthier-Villars et Fils, Paris, 1892.
4. G. V. Schiaparelli, *Il pianeta Marte [The Planet Mars]*, F. Vallardi Editore, Milano, 1893
5. S. Selleri, “Pietro Blaserna, Stanislao Cannizzaro, Antonio Roiti and Giovanni Schiaparelli: Marconi’s Nominators Who Didn’t Make It” in K. Grandin, P. Mazinghi, N. Olander, G. Pelosi (eds.), *A Wireless World, Contribution to the History of the Royal Swedish Academy of Science*, No. 42, Florence, Firenze University Press, 2012, pp. 208-224.
6. G. Pelosi and S. Selleri, “Thomas Young, Not Only Diffracted Rays...,” *IEEE Antennas and Propagation Magazine*, **53**, 5, October 2011, pp. 228-238.
7. E. T. Whittaker, *A History of the Theories of Aether and Electricity*, Dublin, Ireland, Hodges, Friggs & Co., 1910.
8. S. D. Poisson, “Mémoire sur la théorie du magnétisme [Memoire on the Theory of Magnetism],” *Mémoires de l’Academie Royale de France*, **V**, 1824, pp. 247-338.
9. S. D. Poisson, “Second Mémoire sur la théorie du magnétisme [Second Memoire on the Theory of Magnetism],” *Mémoires de l’Academie Royale de France*, **V**, 1824, pp. 488-533.
10. M. Faraday, *Experimental Researches in Electricity*, **I**, 1839, Series XI, exp 1164, 1338, 1343, 1621.
11. K. Z. Markow, “Elementary Micromechanics of Heterogeneous Media,” in K. Z. Markov and L. Preziosi (eds.), *Heterogeneous Media: Modeling and Simulation*, Boston, Birkhauser, 1999, pp. 1-162.

12. E. Agastra and S. Selleri, "The Pavers of Maxwell's Pathway to His Equations," *IEEE Antennas and Propagation Magazine*, **56**, 6, December 2014, pp. 308-316.
13. J. C. Maxwell, "A Dynamical Theory of the Electromagnetic Field," *Philosophical Transactions of the Royal Society*, **155**, 1865, pp. 459-512.
14. J. C. Maxwell, *A Treatise on Electricity and Magnetism, Third Edition*, Oxford, UK, Clarendon Press, 1891.
15. H. Poincaré, *Course de Physique Mathématique: Électricité et Optique – La Lumière – Théories Électrodynamiques – Leçons professées à la Sorbonne en 1888, 1890 et 1899* [Mathematical Physics Course: Electricity and Optics – Light – Electrodynamic Theories – Lessons professed at the Sorbonne in 1888, 1890 and 1899], Paris, Gauthier-Villars, 1901.
16. R. Clausius, *Die mechanische Behandlung der Elektrizität* [The Mechanical Treatment of Electricity], Braunschweig, Vieweg, 1879.
17. R. Landauer, "Electrical Conductivity in Inhomogeneous Media," AIP Conference Proceedings, **40**, Columbus, OH, September 7-9, 1977, pp. 2-43.
18. W. F. Brown, 'Dielectrics', in D. Flügge (ed.), *Encyclopedia of Physics, Volume XII*, Berlin, Springer-Verlag, 1956, pp. 1-154.
19. H. A. Lorentz, *The Theory of Electrons*, Leipzig, B. U. Teubner, 1909.
20. G. R. Lemaître, *Astronomical Optics and Elasticity Theory*, Berlin, Springer Verlaag, 2008.
21. E. Betti, "Commemorazione di O. F. Mossotti [Obituary of O. F. Mossotti]," *Annali di Matematica*, **5**, 1863, p. 60.
22. L. Gabba, "Bibliografia degli Scritti di Ottaviano Fabrizio Mossotti [A bibliography of the writings of Ottaviano Fabrizio Mossotti]," *Bollettino della Sezione di Novara della R. Deputazione Subalpina di Storia Patria*, 1941, no. 4, pp. 273-285.
23. L. Gabba and G. Polvani, *O. F. Mossotti, Scritti* [Writings of O. F. Mossotti], Pisa, Domus Galileiana, 1942-1955.



George Trichopoulos

Electrical, Computer & Energy Engineering ISTB4 555D
Arizona State University

781 E Terrace Road, Tempe, AZ, 85287 USA

Tel: +1 614 364 2090

E-mail: gtrichop@asu.edu

Introducing Georgios Trichopoulos, Associate Editor for Book Reviews

Editor's Note: With this issue Georgios C. Trichopoulos joins the staff of the *Radio Science Bulletin* as Associate Editor for Book Reviews. He will be coordinating and soliciting reviews of books of interest to radio scientists. If you have authored a book, found a book you think might be of interest to our readers, or are interested in reviewing a book, please contact George via e-mail at gtrichop@asu.edu.

Georgios C. Trichopoulos was born in Agrinio, Greece, in April, 1981. He received the Diploma degree in Electrical and Computer Engineering from the Democritus University of Thrace, Xanthi, Greece, in 2004; the MS in Biomedical Engineering from the National Technical University of Athens and University of Patras, Greece (under a joint program) in 2006; and the PhD in Electrical and Computer Engineering from The Ohio State University, Columbus, OH, USA, in 2013.

He is currently an Assistant Professor with the School of Electrical, Computer, and Energy Engineering, Arizona State University, Tempe, AZ, USA. From 2013 to 2015, he was a Postdoctoral Researcher with the ElectroScience Laboratory, The Ohio State University. His research areas include electromagnetic theory, terahertz imaging, antenna design for millimeter-wave and terahertz sensors, and high-frequency device and circuit characterization methods.

Dr. Trichopoulos has been the recipient of several awards, including the Best Student Paper Award of the 2013 IEEE Antennas and Propagation Symposium. He was runner-up for the 2013 Ohio State University Student Innovator Award.

16-th International Conference on Mathematical Methods in Electromagnetic Theory

Come to blend mathematics with electromagnetics for microwave, photonic and plasmonic applications at Europe's Far East – in Ukraine!

MMET is a traditional forum held in Ukraine since 1990. It is famous as efficient interface between the Ukrainian and the Western scientists and engineers in the broad area of modeling and simulation of electromagnetic fields including wave propagation, radiation, emission, scattering, guidance, and processing. Characteristic feature of MMET is a stronger emphasis on the analytical and mathematical aspects of research into electromagnetics. The program consists of only oral presentations (invited and session ones), and English is single working language.

Organizer: IEEE AP/MTT/ED/AES/GRS/NPS East Ukraine Joint Chapter

In cooperation with:

- *I. Franko* Lviv National University (LNU)
- *O.Y. Usikov* Institute of Radio-Physics and Electronics of the National Academy of Sciences of Ukraine
- *G.V. Karpenko* Institute of Physics and Mechanics of the National Academy of Sciences of Ukraine
- URSI and Ukrainian National Committee of URSI
- Other chapters of IEEE AP, MTT, AES, ED, and PH Societies in Ukraine

Expected social program:

Lviv Tour, Visits to Museums and Medieval Castle, Conference Dinner and Farewell Party

Venue:

Lviv, translated as “The city of Lion” was founded in 1256 as a capital city of the powerful medieval Halichyna Duchy; its founder, Grand Duke Danylo was the only duke of the Rurik dynastical roots who was crowned by Pope. Later Lviv played important role in the 14 to the 20 century as one of the major cities in the Polish Kingdom, then the Austro-Hungarian Empire, and finally the Republic of Poland. The Lviv National University, venue of MMET*2016 conference, dates back to 1661 when a Jesuit college was established here by a King's decree. The majestic main building of LNU was the Parliament of Galicia before 1918. After the end of WWII Lviv became the main center of the Western part of Ukraine, then a part of the USSR and independent nation since 1991. Nowadays Lviv is a beautiful city with population about one million (<http://lviv.travel>) and a hub of science, higher education, and IT industry. It is a perfectly safe place in today's turbulent times that is certified by the large expat community and growing numbers of tourists flocking to this ancient symbol of what is sometimes called Ukrainian Piedmont.

Conference chairs:

Prof. Z.T. Nazarchuk, MMET-2016 Chair
Prof. A.I. Nosich, TPC Co-Chair
Dr. O.V. Shramkova, TPC Co-Chair
Prof. V.P. Melnyk, LOC Chair
Prof. K Kobayashi, Int'l Advisory Committee Chair

Important dates:

The MMET*2016 conference will be held on **July 5-7, 2016**. Final 4-page camera-ready papers are expected to be uploaded though the MMET web-site www.mmet.org by **May 10, 2016**. Invited paper authors can present up to 10-page manuscripts.

Address for inquiries:

MMET*16, IRE NASU, vul. Proskury 12, Kharkiv 61085, Ukraine
Tel: +380-57-720-3782, Fax: +380-57-315-2105

No entry visa will be required for the citizens of EU, Switzerland, Norway, USA, Canada, Argentina, Japan, and some other countries.



IEEE RADIO 2015

Her Excellency, Dr. Ameenah Gurib-Fakim, President of the Republic of Mauritius, officially opened (Figure 1) the third edition of the Radio and Antenna Days of the Indian Ocean (IEEE RADIO 2015), which was held at the Long Beach Resort, Belle Mare, Mauritius, from September 21-24, 2015. The conference was organized by the Radio Society (Mauritius), and was sponsored by the IEEE Antennas and Propagation Society, with technical co-sponsorship from the International Union of Radio Science (URSI). The local organizing committee consisted of researchers from the University of Mauritius. The conference was chaired by Prof. Vikass Monebhurrn from Centrale Supélec, France.

IEEE RADIO 2015 was the third in a series of conferences covering the fields of antennas and propagation, organized in the Indian Ocean region. The conference brought together participants from about twenty different countries. IEEE RADIO 2015 featured sixteen oral sessions (Figure 2) on state-of-the-art research themes, including antenna design, electromagnetic compatibility, wireless communication, wireless power transfer, numerical modeling, and medical and industrial applications of electromagnetic fields. A half-day workshop was organized by CST on the first day of the conference to present the latest version of the CST *Studio Suite*.

Invited talks were delivered by Prof. Tapan Sarkar from Syracuse University, USA; Dr. Eric Mokole, retired from the Naval Research Laboratory, USA; and Prof. Russell Taylor from the University of Cape Town and University of Western Cape, South Africa. A half-day tutorial was also organized by Prof. Tapan Sarkar and Dr. Eric Mokole on the last day of the conference.

Seven young scientists from developing countries received partial financial support to attend IEEE RADIO 2015. A special session was dedicated to their presentations,



Figure 1. The opening ceremony (l-r): Her Excellency, Dr. Ameenah Gurib-Fakim, President of the Republic of Mauritius, Prof. Vikass Monebhurrn, General Chair of IEEE RADIO 2015, and Prof. Tapan Sarkar, Past-President of IEEE AP-S.

which were evaluated by a jury. There were also about twenty student presentations that were evaluated by the same jury. During the closing ceremony of the conference, prizes and certificates were awarded to young scientists and students. Three cash prizes of 300 Euros, 200 Euros, and 100 Euros were awarded to the three best student papers, as well as to the three best presentations by Young Scientists.

Following the success of the three editions of the RADIO international conferences, all organized in Mauritius, the local organizing committee is considering holding the next edition of the conference at Réunion Island, in 2016.

Vikass Monebhurrn
General Chair, IEEE RADIO 2015
E-mail: vikass.monebhurrn@centralesupelec.fr



Figure 2. The Monday morning session.

The James Clerk Maxwell Foundation

The James Clerk Maxwell Foundation is a nonprofit foundation with two purposes, as stated on its Web site:

1. To promote, encourage, and advance the study of, research into, and the dissemination of knowledge of and relating to physics, chemistry and physical chemistry in all their aspects and in particular, but without prejudice to the foregoing generality, colloids and interfaces.
2. To commemorate, by publishing or contributing towards or promoting the publication in any way (but not with a view to profit) of scientific or educational books, films, papers, essays, monographs and/or lectures on or relating to physics and chemistry or any aspect thereof,

the said James Clerk Maxwell and any other person or persons who may in the opinion of the Trustees have contributed significantly to the advancement of physics or chemistry.

The foundation is located in and owns the birthplace home of James Clerk Maxwell, in Edinburgh, Scotland. Its Web site is at <http://www.clerkmaxwellfoundation.org>. The foundation publishes a newsletter, containing interesting historical articles about Maxwell and his work. Current and past issues of the newsletter are available from the Web site. Radio scientists interested in receiving e-mail notification when a new issue of the newsletter is available can contact the foundation via its Web site. The foundation also arranges tours of Maxwell's birthplace by appointment.

www.gass2017.org

URSI 2017 GASS
XXXIInd URSI GENERAL ASSEMBLY
& SCIENTIFIC SYMPOSIUM

Welcome to Montréal in August 19-26, 2017
for the XXXI^{Ind} General Assembly and Scientific Symposium
(GASS) of the International Union of Radio Science (URSI)

Enjoy, in addition to an outstanding Scientific Program and fruitful Business Meetings, exceptional celebrations in the context of the:

- 375th Anniversary of Montréal
- 50th Anniversary of Expo 67
- 150th Anniversary of Canada.

URSI

Please, mark your calendar now!

Christophe Caloz, Polytechnique Montréal, General Chair
Ahmed Kishk, Concordia University, Vice Chair

375th

Anniversary of Montréal • 50th Anniversary of Expo 67 • 150th Anniversary of Canada

USNC-URSI 2016 National Radio Science Meeting Student Paper Competition

The US National Committee (USNC) of URSI held its National Radio Science Meeting January 6-9, 2016, in Boulder, Colorado, USA. The Ernest K. Smith Student Paper Competition is organized at each National Radio Science Meeting. Papers are reviewed by representatives of the 10 USNC-URSI Commissions, and the top three authors are invited to present their research at a special plenary session. The 2016 winners were as follows (there was a tie for second place):

First Prize: “Experimental Validation of Mode Dominance Reversal in Novel Slow Wave Structure for High Power Backward Wave Oscillators” (Commission B) by Ushemadzoro Chipengo (Figure 1) and John L. Volakis (advisor), ElectroScience Laboratory, Department of Electrical and Computer Engineering, The Ohio State University, Columbus, OH



Figure 1. (l-r) John Volakis (advisor), First Prize winner Ushemadzoro Chipengo, and Erdem Topsakal, Chair of the Student Paper Competition.



Figure 2. Erdem Topsakal (l) and Second Prize winner Mohammad A. Salem.



Figure 3. Second Prize winner Ersin Yetisir.

Second Prize: “Modification of the Lower Ionospheric Conductivity by Thunderstorm Electrostatic Fields” (Commission H) by Mohammad A. Salem (Figure 2), Ningyu Liu (advisor), and Hamid K. Rassoul Geospace Physics Laboratory, Department of Physics and Space Sciences, Florida Institute of Technology, Melbourne, FL

Second Prize: “A Novel Array with 6:1 Bandwidth and 70° Scanning Using FSS Superstrate” (Commission B) by Ersin Yetisir (Figure 3), Nima Ghalichechian, and John L. Volakis (advisor), ElectroScience Laboratory, Department of Electrical and Computer Engineering, The Ohio State University, Columbus, OH

A group photo of the winners, their advisors, and USNC-URSI organizers is shown in Figure 4.



Figure 4. (l-r) John Volakis, First Prize winner Ushemadzoro Chipengo, David Jackson (Chair of USNC-URSI), Erdem Topsakal, Second Prize Winner Mohammad A. Salem, Ningyu Liu (advisor), and Second Prize Winner Ersin Yetisir.

December 2015

ICMARS 2015

11th International Conference on Microwaves Antenna Propagation & Remote Sensing

Jodhpur, Rajasthan, India, 15-17 December 2015

Contact: Contact: Prof. O.P.N. Calla, ICRS, Plot No 1, Rano ji Ka Bagh, Khokhariya Bera, Nayapura, Mandore, Jodhpur 342304 Rajasthan, India, Fax +91 291-257 1390
<http://www.icmars.org>

April 2016

EuCAP 2016

European Conference on Antennas and Propagation 2016

Davos, Switzerland, 10 - 15 April 2016

Contact: Prof. Juan R. Mosig, LEMA – EPFL, École Polytechnique Fédérale de Lausanne, Lausanne, Switzerland, E-mail juan.mosig@epfl.ch
<http://www.eucap2016.org>

May 2016

CROWNCOM 2016

11th International Conference on Cognitive Radio Oriented Wireless Networks and Communications

Grenoble, France, 30 May - 1 June 2016

Contact: Prof. Jacques Palicot, SUPELEC/IETR, Avenue de la Boulaie, CS 47601 F35576 Cesson-Sévigné, France, E-mail: jacques.palicot@centralesupelec.fr
<http://crowncom.org/2016>

June 2016

EUSAR 2016 - European Conference on Synthetic Aperture Radar 2016

Hamburg, Germany, 6-9 June 2016

Contact: EUSAR 2016 Conference Office c/o VDE, Ms. Hatice Altintas, Stresemannallee 15, D-60596 Frankfurt, Germany
Fax: +49 69 96 31 52 13, E-Mail: Hatice.altintas@vde.com
<http://www.eusar.de>

MetroAeroSpace 2016

3rd IEEE International Workshop on Metrology for Aerospace

Firenze, Italy, 22-23 June 2016

Contact: Contact: L. Ciani, Univ. of Florence, Dept of Information Engineering, via di S. Marta 3, 50139 Florence, Italy, E-mail: lorenzo.ciani@unifi.it and L. De Vito, Univ.

of Sannio, Dept of Engineering, 82100 Benevento, Italy,
E-mail: devito@unisannio.it
<http://lesim1.ing.unisannio.it>

July 2016

COSPAR 2016

41st Scientific Assembly of the Committee on Space Research (COSPAR) and Associated Events

Istanbul, Turkey, 30 July – 7 August 2016

Contact: COSPAR Secretariat, 2 place Maurice Quentin, 75039 Paris Cedex 01, France, Tel: +33 1 44 76 75 10, Fax: +33 1 44 76 74 37, E-mail: cospar@cosparhq.cnes.fr
<https://www.cospar-assembly.org/>

August 2016

EMTS 2016

2016 URSI Commission B International Symposium on Electromagnetic Theory

Espoo, Finland, 14-18 August 2016

Contact: Prof. Ari Sihvola, Aalto University, School of Electrical Engineering, Department of Radio Science and Engineering, Box 13000, FI-00076 AALTO, Finland, E-mail: ari.sihvola@aalto.fi

HF13

Nordic HF Conference with Longwave Symposium LW 13

Faro, Sweden (north of Gotland in the Baltic Sea), 15-17 August 2016

Contact: Carl-Henrik Walde, Tornvägen 7, SE-183 52 Taby, Sweden, tel +46 8 7566160 (manual fax switch, E-mail info@walde.se)
<http://www.ursi.org/img/website24x24.jpg>

AP-RASC 2016

2016 URSI Asia-Pacific Radio Science Conference

Seoul, Korea, 21 - 25 August 2016

Contact: URSI AP-RASC 2016 Secretariat, Genicom Co Ltd, 2F 927 Tamnip-dong, Yuseong-gu, Daejeon, Korea 305-510, Fax.: +82-42-472-7459, E-mail: secretariat@apasc2016.org
<http://www.ursi.org/img/website24x24.jpg>

September 2016

ICEAA 2016

Eighteenth edition of the International Conference on Electromagnetics in Advanced Applications

Cairns, Australia, 19-23 September 2016

Contact: Prof. Guido Lombardi, Politecnico di Torino,

E-mail: iceaa16@iceaa.polito.it
<http://www.iceaa-offshore.org/j3/>

Metamaterials 2016

10th International Congress on Advanced Electromagnetic Materials in Microwaves and Optics

Chania, Greece, 19-22 September 2016

Contact: <http://congress2016.metamorphose-vi.org/>

<http://congress2016.metamorphose-vi.org>

VERSIM 2016

VLF/ELF Remote Sensing of Ionospheres and Magnetospheres Workgroup

Hermanus, Western Cape, South Africa, 19-23 September 2016

Contact: VERSIM@sansa.org.za

<http://events.sansa.org.za/versim-information>

October 2016

RFI 2016

Radio Frequency Interference 2016

Socorro, NM, USA, 10-13 October 2016

Contact: Prof. Willem Baan, Asserweg 45, NL-9411 LP Beilen, The Netherlands, E-mail: baan@astron.nl

(website in preparation)

RADIO 2016

IEEE Radio and Antenna Days of the Indian Ocean 2016

Réunion Island, 10-13 October 2016

Contact: radio2016@radiosociety.org

<http://www.radiosociety.org/radio2016/>

ISAP 2016

2016 International Symposium on Antennas and Propagation

Okinawa, Japan, 24-28 October 2016

Contact: Prof. Toru Uno, Tokyo Univ. of Agriculture & Technology, Dept of Electrical and Electronic Engineering, 2-24-16 Nakamachi, Koganei 184-8588, Japan, Fax +81 42-388 7146, E-mail: uno@cc.tuat.ac.jp

<http://isap2016.org/>

August 2017

URSI GASS 2017

XXXIInd URSI General Assembly and Scientific Symposium

Montreal, Canada, 19-26 August 2017

Contact: URSI Secretariat, c/o INTEC, Sint-Pietersnieuwstraat 41, 9000 Gent, Belgium, E-mail info@ursi.org

May 2019

EMTS 2019

2019 URSI Commission B International Symposium on Electromagnetic Theory

San Diego, CA, USA, 27-31 May 2019

Contact: Prof. Sembiam R. Rengarajan, California State University, Northridge, CA, USA, Fax +1 818 677 7062,

E-mail: srengarajan@csun.edu

URSI cannot be held responsible for any errors contained in this list of meetings

International Geophysical Calendar 2016

	S	M	T	W	T	F	S		S	M	T	W	T	F	S	
January						1	2							1	2	July
	3	4	5 ⁺	6 ⁺	7 ⁺	8 ⁺	9 ⁺		3	4 ^{N*}	5 [*]	6 [*]	7	8	9	
	10 ^N	11 ⁺	12 ⁺	13 [*]	14	15	16		10	11	12	13	14	15	16	
	17	18	19	20	21	22	23		17	18	19 ^F	20	21	22	23	
	24 ^F	25	26	27	28	29	30		24	25	26	27	28	29	30	
February	31	1	2	3	4	5 ⁺	6 ⁺		31	1 [*]	2 ^{N*}	3 [*]	4	5	6	August
	7 ⁺	8 ^{N*}	9 ⁺	10 [*]	11	12	13		7	8	9	10	11	12	13	
	14	15	16	17	18	19	20		14	15	16	17	18 ^F	19	20	
	21	22 ^F	23	24	25	26	27		21	22	23	24	25	26	27	
March	28	29	1	2	3	4	5 ⁺		28	29	30	31 [*]	1 [*]	2 [*]	3	September
	6 ⁺	7 ⁺	8 [*]	9 [*]	10 [*]	11 ⁺	12 ⁺		4	5	6	7	8	9	10	
	13 ⁺	14 ⁺	15 ⁺	16 ^F	17 ⁺	18 ⁺	19 ⁺		11	12	13	14	15	16 ^F	17	
	20	21	22	23 ^F	24	25	26		18	19	20	21	22	23	24	
April	27	28	29	30	31	1	2		25	26	27	28 [*]	29 [*]	30 [*]	1 ^N	October
	3	4	5	6 [*]	7 ^{N*}	8 [*]	9		2	3	4	5 [*]	6	7	8	
	10	11	12	13	14	15	16		9	10	11	12	13	14	15	
	17	18	19	20	21	22 ^F	23		16 ^F	17	18	19	20	21	22	
	24	25	26	27	28	29	30		23	24	25	26	27	28	29	
May	1	2	3	4 [*]	5 [*]	6 ^{N*}	7		30 ^N	31 [*]	1 [*]	2 [*]	3	4	5	November
	8	9	10	11	12	13	14		6	7	8	9 [*]	10	11	12	
	15	16	17	18	19	20	21 ^F		13	14 ^F	15	16	17	18	19	
	22	23	24	25	26	27	28		20	21	22	23	24	25	26	
June	29	30	31	1	2	3	4		27	28 [*]	29 ^{N*}	30 [*]	1 ⁺	2 ⁺	3 ⁺	December
	5 ^N	6 [*]	7 [*]	8 [*]	9	10	11		4	5	6	7 [*]	8	9	10	
	12	13	14	15	16	17	18		11	12	13	14 ^F	15	16	17	
	19	20 ^F	21	22	23	24	25		18	19	20	21	22	23	24	
	26	27	28	29	30				25	26	27	28 [*]	29 ^{N*}	30 [*]	31	
	S	M	T	W	T	F	S		1	2	3	4 [*]	5	6	7	2017
									8	9	10	11	12 ^F	13	14	January
									15	16	17	18	19	20	21	
									22	23	24	25 [*]	26 [*]	27 [*]	28 ^N	
									29	30	31					
									S	M	T	W	T	F	S	
										N	NEW MOON		F	FULL MOON		

12 Regular World Day (RWD)

13 Priority Regular World Day (PRWD)

10 Quarterly World Day (QWD)
also a PRWD and RWD

6 Regular Geophysical Day (RGD)
World Geophysical Interval (WGI)

1 2

+ Incoherent Scatter Coordinated Observation Day
(The period March 5-19 is a Meridian Circle Alert interval.
During this time all radars will operate for the same five days
continuously. The precise timing of the 5 day interval will
be based on predictions of magnetic disturbances.)

9 Days of Solar Eclipse: March 9, total; Sept 1, annula

6 7 Airglow and Aurora Period

11* Dark Moon Geophysical Day (DMGD)

This Calendar continues the series begun for the IGY years 1957-58, and is issued annually to recommend dates for solar and geophysical observations, which cannot be carried out continuously. Thus, the amount of observational data in existence tends to be larger on Calendar days. The recommendations on data reduction and especially the flow of data to World Data Centers (WDCs) in many instances emphasize Calendar days. The Calendar is prepared by the International Space Environment Service (ISES) with the advice of spokesmen for the various scientific disciplines.

The Calendar provides links to many international programs, giving an opportunity for scientists to become involved with data monitoring and research efforts. International scientists are encouraged to contact key people and to join the worldwide community effort to understand the Sun-Earth environment.

The definitions of the designated days remain as described on previous Calendars. Universal Time (UT) is the standard time for all world days. Regular Geophysical Days (RGD) are each Wednesday. Regular World Days (RWD) are three consecutive days each month (always Tuesday, Wednesday and Thursday near the middle of the month). Priority Regular World Days (PRWD) are the RWD which fall on Wednesdays. World Geophysical Intervals (WGI) are 14 consecutive days in each season, beginning on Monday of the selected month, and normally shift from year to year. In 2016 the WGI are February, May, August, and November. Quarterly World Days (QWD) are one day each quarter and are the PRWD which fall in the WGI. The 2016 FINAL Calendar is available in PDF format.

2016 Solar Eclipses:

A total solar eclipse will sweep across western and northern Indonesia and into the Pacific on 9 March 2016, and an annular solar eclipse will cross Africa from Gabon to Tanzania to Madagascar, and on to the island of Réunion on 1 September 2016. Maps are accessible through <http://www.eclipses.info>, the site for the International Astronomical Union's Working Group on Eclipses.

- a. **09 March 2016.** The total eclipse path crosses the Indonesian Islands of Sumatra, Borneo, Sulawesi, Ternate, and then onward into the Pacific, where mid-eclipse occurs with a maximum totality of 4 m 9 s. Cloudiness statistics based on past satellite data are available at <http://eclipser.ca>. On Ternate, at an altitude of about 47°, there is a maximum totality of 2 m 45 s, with the centerline farther south of about 3 m 15 s. Partial phases will be visible at sunrise in eastern India and southeastern Asia northward through most of China. Northern Australia will have about 60% coverage, with the northwestern two-third of Australia in the partial-eclipse zone. Hawaii will have over 60% of the Sun's diameter covered, with 70% partial eclipse in Honolulu in the late afternoon, about an hour before sunset. Map of total solar eclipse 09 March 2016 (by Fred

Espenak)

Interactive Google map of total solar eclipse 09 March 2016 (by Xavier Jubier)

- b. **01 September 2016.** The 97% (of the solar diameter) annular path (94% of the area) crosses Africa from Gabon through Congo and DR Congo through southern Tanzania to northern Mozambique and northern Madagascar, and on to the French island of Réunion. All of Africa except for the Mediterranean coast and inland regions will have a partial eclipse, with 26% of the solar diameter covered in Cape Town, South Africa. The peak duration of annularity, in southern Tanzania, will be 3 m 6 s, with a possible subtraction of about 15 s for Baily's beads. Calculations show about 2 m 51 s in southern Réunion, with a possible subtraction of about 15 s for Baily's beads. Map of partial solar eclipse 01 September 2016 (by Fred Espenak)
Interactive Google map of partial solar eclipse 01 September 2016 (by Xavier Jubier)

We thank Fred Espenak (Arizona) (<http://EclipseWise.com>) and Xavier Jubier (Paris) (<http://xjubier.free.fr/en/>) for their data and maps; see also Michael Zeiler's <http://eclipse-maps.com> for maps and Jay Anderson's <http://eclipser.ca> for weather discussions. Espenak's Thousand Year Canon of Solar Eclipses: 1501 to 2500 is available from www.astropixels.com/pubs, and is the successor to earlier Canons and the NASA website that he ran. It and other work of Espenak, much of it formerly on the NASA website, is now available at <http://EclipseWise.com>. Information assembled by Jay M. Pasachoff, Williams College (Williamstown, Massachusetts), Chair, International Astronomical Union's Working Group on Eclipses.

Eclipse References:

- Pasachoff website linking much eclipse reference material: <http://eclipses.info>
- Fred Espenak, Thousand Year Canon of Solar Eclipses 1501 to 2500, 2014 (ISBN-10: 194 1983006); www.astropixels.com/pubs
- Fred Espenak, Five Millennium Canon of Solar Eclipses: -1999 to +3000, 2006 (NASA/TP-2006-214141); <http://eclipse.gsfc.nasa.gov>; <http://eclipse.gsfc.nasa.gov/OH/OH2014.html>
- Leon Golub and Jay M. Pasachoff, The Solar Corona, 2nd ed., Cambridge University Press, 2010 (ISBN-10: 052188201X). Jay M. Pasachoff and Alex Filippenko, The Cosmos: Astronomy in the New Millennium, 4th ed., Cambridge University Press, 2014 (ISBN-10: 049501303X).
- Leon Golub and Jay M. Pasachoff, Nearest Star: The Surprising Science of Our Sun, 2nd edition, Cambridge University Press, 2014 (ISBN-10: 1107672643).
- Jay M. Pasachoff, The Complete Idiot's Guide to the Sun, Alpha Books, 2003 (ISBN-10: 1592570747).

2016 Meteor Showers

(Selected from data compiled by Jürgen Rendtel for the International Meteor Organization Shower Calendar):

- a. **Meteor outbursts** are unusual showers (often of short duration) from the crossing of relatively recent comet ejecta. Dates are for the year 2016.
- 21 April (comet P/2009 WX₅₁): Possibility of activity at 02:02 UT.
 - 12 September (ϵ -Eridanids): Possible outburst around 17:30 UT.
 - 05 October: Possibility of outbursts for the October 5/6 meteors, sometimes called the October Camelopardalids, around 05 October 2016 14:45 UT.
- b. **Annual meteor showers liable to have geophysical effects:** Dates (based on UT in year 2016) are:

Dates, Peak Time (UT), Name

Dec 28-January, 12 Jan 04, 08:00, Quadrantids (QUA)¹
Jan 28-Feb 21, Feb 08, 18:30, α -Centaurids (ACE)²
April 16-April 25, April 22, 06:00, Lyrids (LYR)
April 19-May 28, May 05, 20:00, η -Aquariids (ETA)
May 14-June 24, June 07, Daytime Arietids (ARI)³
May 20-July 05, June 09, Daytime ζ -Perseids (ZPE)³
June 05-July 17, June 28, Daytime β -Taurids (BTA)
July 12-August 23, July 30 (possibly July 28-30)
Southern δ -Aquariids (SDA)
July 17-Aug 24, Aug 12 13:00 to 15:30, Perseids (PER)
Sept 09-Oct 09, Sept 27, Daytime Sextantids (DSX)
Oct 02-Nov 07, October 21, Orionids (ORI)
Nov 06-Nov 30, Nov 17, Leonids (LEO)
Dec 04-Dec 17, Dec 14, Geminids (GEM)
Dec 17-Dec 26, Dec 22, 09:00, Ursids (URS)⁴

- 1 Quadrantids (QUA): Model calculations of Jérémie Vaubaillon indicate the peak may occur earlier with a maximum between January 3, 22 UT and January 4, 02 UT.
- 2 α -Centaurids (ACE): IMO observations found the timing of the mean of 'traditional' broad maximum varied between August 12 08 UT to 22 UT. Mikhail Maslov and Esko Lyytinen indicate we will cross a part of the stream which was shifted closer to the Earth's orbit by Jupiter in 2016, which could result in background ZHR levels of 150-160. Earth should encounter small meteoroids already on August 11 22:34 UT with brighter meteors expected at 23:23 UT. Jérémie Vaubaillon anticipates the densest part of the stream will be crossed August 12 between 00 UT and 04 UT, well before the broad nodal maximum.
- 3 Daytime Arietids (ARI) and Daytime ζ -Perseids (ZPE): Shower maxima dates are not well established and may occur up to a day later than indicated.
- 4 Ursids (URS): No unusually strong activity has been forecast, although modelling by Jérémie Vaubaillon suggests a possibility of weak activity December 22/23 (more likely) and 23/24, close to 00 UT each night.

c. **Annual meteor showers which may have geophysical effects:** Dates (based on UT in year 2016) are:

Dates, Peak Time (UT), Name

April 15-April 28, April 23, π -Puppids (PPU)
June 22-July 02, June 27 03:00, June Boötids (JBO)¹
Aug 28-Sept 05, Aug 31, 19:00, α -Aurigids (AUR)
Sept 05-Sept 21, Sept 09, 04:00 Sept, ϵ -Perseids (SPE)
Oct 06-Oct 10, October 08, Draconids (DRA)
Nov 15-Nov 25, Nov 21, α -Monocerotids (AMO)
1 June Boötids (JBO): Some June Boötids may be visible in most years around June 20-25, but with activity largely negligible except near June 23, 2016. Particles which may encounter the Earth are expected to be small and will not produce visual activity, although radar may detect signs of the trail.

Meteor Shower Websites:

- Shower activity near-real time reports -- International Meteor Organization
- Meteor shower activity forecast from your own location -- Meteor Shower Flux Estimator
- Shower names and data -- IAU Meteor Data Center
- Announcements and reports of meteor outbursts -- IAU Minor Planet Center
- Shower outburst activity forecast -- Institut de Mécanique céleste et de calcul des éphémérides (IMCCE)

Meteor Shower References:

- Handbook for Meteor Observers, edited by Jürgen Rendtel and Rainer Arlt, IMO, 2014.
- Meteor Shower Workbook, edited by Jürgen Rendtel, IMO, 2014.
- A Comprehensive List of Meteor Showers Obtained from 10 Years of Observations with the IMO Video Meteor Network, by Sirko Molau and Jürgen Rendtel (WGN, the Journal of the IMO 37:4, 2009, pp. 98-121).
- Peter Jenniskens, Meteor showers and their parent comets. Cambridge University Press, 2006, 790 pp.

Real Time Space Weather and Earth Effects

The occurrence of **unusual solar or geophysical conditions** is announced or forecast by ISES through various types of geophysical "**Alerts**" (which are widely distributed via the internet on a current schedule). Stratospheric warmings (STRATWARM) were also designated for many years. The meteorological telecommunications network coordinated by the World Meteorological Organization (WMO) carries these worldwide Alerts once daily soon after 0400 UT. For definitions of Alerts see ISES URSIgram Codes.

RECOMMENDED SCIENTIFIC PROGRAMS (FINAL EDITION)

(The following material was reviewed in 2015 by the ISES committee with the advice of representatives from the various scientific disciplines and programs represented as suitable for coordinated geophysical programs in 2016.)

Airglow and Aurora Phenomena.

Airglow and auroral observatories operate with their full capacity around the New Moon periods. However, for progress in understanding the mechanism of many phenomena, such as low latitude aurora, the coordinated use of all available techniques, optical and radio, from the ground and in space is required. Thus, for the airglow and aurora 7-day periods on the Calendar, ionosonde, incoherent scatter, special satellite or balloon observations, etc., are especially encouraged. Periods of approximately one weeks' duration centered on the New Moon are proposed for high resolution of ionospheric, auroral and magnetospheric observations at high latitudes during northern winter.

Atmospheric Electricity.

Non-continuous measurements and data reduction for continuous measurements of atmospheric electric current density, field, conductivities, space charges, ion number densities, ionosphere potentials, condensation nuclei, etc.; both at ground as well as with radiosondes, aircraft, rockets; should be done with first priority on the RGD each Wednesday, beginning on 06 January 2016 at 0000 UT, 13 January at 0600 UT, 20 January at 1200 UT, 27 January at 1800 UT, etc. (beginning hour shifts six hours each week, but is always on Wednesday). Minimum program is at the same time on PRWD beginning with 13 January at 1200 UT. Data reduction for continuous measurements should be extended, if possible, to cover at least the full RGD including, in addition, at least 6 hours prior to indicated beginning time. Measurements prohibited by bad weather should be done 24 hours later. Results on sferics and ELF are wanted with first priority for the same hours, short-period measurements centered around minutes 35-50 of the hours indicated. Priority Weeks are the weeks that contain a PRWD; minimum priority weeks are the ones with a QWD. The World Data Centre for Atmospheric Electricity, 7 Karbysheva, St. Petersburg 194018, USSR, is the collection point for data and information on measurements.

Geomagnetic Phenomena.

It has always been a leading principle for geomagnetic observatories that operations should be as continuous as possible and the great majority of stations undertake the same program without regard to the Calendar. Stations equipped for making magnetic observations, but which cannot carry out such observations and reductions on a continuous schedule are encouraged to carry out such work at least on RWD (and during times of MAGSTORM Alert).

Ionospheric Phenomena.

Special attention is continuing on particular events that cannot be forecast in advance with reasonable certainty. The importance of obtaining full observational coverage is therefore stressed even if it is only possible to analyze the detailed data for the chosen events. In the case of vertical incidence sounding, the need to obtain quarter-hourly ionograms at as many stations as possible is particularly stressed and takes priority over recommendation (a) below when both are not practical.

For the **vertical incidence (VI) sounding** program, the summary recommendations are:

- a. All stations should make soundings on the hour and every quarter hour;
- b. On RWDs, ionogram soundings should be made at least every quarter hour and preferably every five minutes or more frequently, particularly at high latitudes;
- c. All stations are encouraged to make f-plots on RWDs; f-plots should be made for high latitude stations, and for so-called "representative" stations at lower latitudes for all days (i.e., including RWDs and WGI) (Continuous records of ionospheric parameters are acceptable in place of f-plots at temperate and low latitude stations);
- d. Copies of all ionogram scaled parameters, in digital form if possible, be sent to WDCs;
- e. Stations in the eclipse zone and its conjugate area should take continuous observations on solar eclipse days and special observations on adjacent days. See also recommendations under Airglow and Aurora Phenomena.

For the **incoherent scatter observation program**, every effort should be made to obtain measurements at least on the Incoherent Scatter Coordinated Observation Days, and intensive series should be attempted whenever possible in WGIs, on Dark Moon Geophysical Days (DMGD) or the Airglow and Aurora Periods. The need for collateral VI observations with not more than quarter-hourly spacing at least during all observation periods is stressed.

Special programs include:

- **Day-night connection by localised flow channels: Coordination with Heliophysics System Observatory campaign: 20160105-20160111**

Key objectives:

To determine structure of fast flow channels forming on the dayside cusp region and their propagation across the polar cap toward the nightside auroral oval

To determine impact of fast flow channels on global plasma circulation processes, including magnetic reconnection, flux transfer events, plasma sheet flow bursts, and subauroral polarization streams

Background condition: To take advantage of THEMIS-MMS conjunctions during dark-sky conditions, the proposed runs should be performed during January 5-15, 2016.

Primary parameters to measure: F-region (150-800 km altitude) key parameters including N_e , T_e , T_i and V_i at highest time resolution. For AMISRs, the THEMIS-mode beam pattern is requested for obtaining wide FOV and dense coverage. For Sondrestrom and ESR a combination of fast azimuth scans and elevation scans are preferred, and EISCAT VHF and UHF are suggested to run a combination of vertical and low elevation north modes but these are negotiable. For Millstone Hill, azimuth scans at low elevation for SAPS measurements are requested. Jicamarca and Arecibo will measure penetration electric fields.

Need for simultaneous data: In early 2016, MMS

and THEMIS will be on the dayside and nightside, respectively, for measuring disturbances related to reconnections for the first time. Ground-based observations are essential for connecting day and night processes as well as providing 2-D perspective of flow structures, because such processes are expected to have flow channels around the cusp propagating deep into the polar cap associated with PMAFs and polar cap patches, and occasionally leading to nightside auroral intensifications. In addition, flows in the nightside plasma sheet penetrate to lower L-shells and can be measured as enhanced electric fields by mid-equatorial radars. We therefore need all radars to be operating at the same time.

Principal investigator: Toshi Nishimura, University of California, Los Angeles (toshi@atmos.ucla.edu)

Co-investigators: Vassilis Angelopoulos, Larry Lyons, Mike Nicolls, J. Mike Ruohoniemi, Eric Donovan, Emma Spanswick, Joran Moen, Lasse Clausen, Kjellmer Oksavik, Joshua Semeter, Marilia Samara, Robert Michell, Donald Hampton, David Knudsen, Kazuo Shiokawa

– **Gravity wave propagation in the mesosphere and thermosphere: 20160205-20160209**

Key objectives:

To measure the electron density and temperature profiles in the mesosphere and thermosphere during the German GW-LCYCLE cycle

To extract gravity wave parameters in the mesosphere and thermosphere for comparison with lower atmosphere and SuperDARN observations

Background condition: Quiet geomagnetic conditions are preferred to improve the ability to extract gravity wave parameters from waves forced from the lower atmosphere, either by direct propagation or secondary generation. Clear skies are preferred to allow optical support.

Primary parameters to measure: Local near vertical profiles of N_e , T_e and V_i from the mesosphere to the F-region with high time resolution.

Need for simultaneous data: An opportunity to examine the large scale gravity wave field at various longitudes.

Principal investigator: Andrew Kavanagh, British Antarctic Survey, Cambridge, UK (andkav@bas.ac.uk)

Co-investigators: Tracy Moffat-Griffin (BAS); Adrian Grocott (Lancaster University); Lisa Baddeley (UNIS); Dag Lorentzen (UNIS), Noora Partamies (UNIS)

– **Meridian Circle (MERINO): 20160305-20160319 (five day run in 15 day alert period)**

Key objectives:

Collect synthesized upper atmosphere data along a complete meridian circle, for investigation of geospace processes associated with space weather

To determine latitudinal variations and their east-west hemispheric differences during solar storms

Background condition: The aim is to run during a magnetic storm, with a five-day continuous observation providing both storm conditions and a quiet-time reference. The exact dates will be selected about

three days before the start of the campaign, based on predictions of magnetic activity. If no major disturbances are anticipated, the campaign period will be selected on the basis of recurrent magnetic activity.

Primary parameters to measure: Synoptic modes for mid and low latitude radars; Low elevation AZ scans + regional mode for Millstone Hill. Convection measurements for high-latitude radars.

Need for simultaneous data: The coordinated observing project involves ISR World Day participants as well as the Chinese Meridian Circle project facilities. This major Chinese project provides comprehensive ground-based space weather observing in the Eastern Hemisphere, in particular along the 120E longitude, where 15 observatories, including an ISR, distributed from northern China to the South Pole, are established. They are equipped with, among other instruments, ionospheric radio sensors (digisondes, GPS receivers, MF radars, coherent radars, etc) and optical sensors (Lidars, FPIs, all-sky imagers). For this campaign, intensive observational modes will be adopted for most of the instruments.

Principal investigator: Shunrong Zhang, MIT Haystack Observatory, USA (shunrong@haystack.mit.edu)

Co-investigators: Guotao Yang and Zhaohui Huang (National Space Science Center, China); John Foster (MIT Haystack Observatory, USA)

Time: Five days in the alert period from 5-19 March. Shunrong will be responsible for issuing the alert notice, which will be around three days in advance of the experiment start.

– **Development of decameter-scale field-aligned irregularities following sudden changes in the drift direction of polar cap patches: 20161128-20161202**

Key objectives:

To measure the growth rate of decameter-scale field-aligned irregularities associated with polar cap patches
To evaluate the theory of gradient drift instability in the polar cap, and to assess its role as a source of HF coherent backscatter

To study the effect of sudden convection flow change on the development of decameter-scale field-aligned irregularities associated with polar cap patches

To investigate the effect of sudden flow change on the rotation and density distribution of a polar cap patch

To study the time history of the irregularities by tracking a patch through multiple ISR and HF radar fields of view (FOVs)

Background condition: We wish to run during and near new moon periods in the winter season for optimal optical conditions, during any geomagnetic conditions. Since we hope to observe patches as they evolve during their transport across the polar cap, the most favorable time of observations would be between 04 UT and 18 UT, since during this time frame, assuming a southward IMF configuration, the likelihood of patches drifting over several ISRs is highest.

Primary parameters to measure: Horizontal profiles of the F-region electron density, ion-drifts and electric

fields, ion and electron temperatures. For specific radar modes we suggest running horizontal scans towards north for EISCAT UHF and ESR, the composite scan mode for Sondrestrom, a 6 x 7 beam grid mode for RISR-N (as used during the 'optics' mode in Feb 2012) and RISR-C and the 11 x 11 Semeter Nov 2007 beam mode for PFISR.

Need for simultaneous data: Our objectives require us to monitor the time history of the patches as they traverse multiple local time sectors in the high latitude region, which is only possible using several ISRs.

Principal investigator: Hanna Dahlgren, KTH Royal Institute of Technology, Stockholm, Sweden (hannad@kth.se); Gareth Perry, University of Calgary, Canada (perry@phys.ucalgary.ca)

Co-investigators: Joshua Semeter, Boston University, USA (jls@bu.edu)

- **AO -- Arecibo Observatory**
- **JRO -- Jicamarca Radio Observatory.**

Special programs: Ian McCrea, Rutherford Appleton Laboratory, UK; tel:+44(0)1235 44 6513; Fax:+44(0)1235 44 5848; email: ian.mccrea@stfc.ac.uk, chair of URSI ISWG (Commission G). See the Incoherent Scatter Coordinated Observation Days (URSI-ISWG) webpage for complete 2015 definitions.

For the **ionospheric drift** or wind measurement by the various radio techniques, observations are recommended to be concentrated on the weeks including RWDs.

For **travelling ionosphere disturbances**, propose special periods for coordinated measurements of gravity waves induced by magnetospheric activity, probably on selected PRWDs and RWDs.

For the **ionospheric absorption** program half-hourly observations are made at least on all RWDs and half-hourly tabulations sent to WDCs. Observations should be continuous on solar eclipse days for stations in the eclipse zone and in its conjugate area. Special efforts should be made to obtain daily absorption measurements at temperate latitude stations during the period of Absorption Winter Anomaly, particularly on days of abnormally high or abnormally low absorption (approximately October-March, Northern Hemisphere; April-September, Southern Hemisphere).

For **back-scatter and forward scatter** programs, observations should be made and analyzed at least on all RWDs.

For synoptic observations of **mesospheric (D region) electron densities**, several groups have agreed on using the RGD for the hours around noon.

For **ELF noise measurements of earth-ionosphere cavity resonances** any special effort should be concentrated during WGIs.

It is recommended that more intensive observations in all programs be considered on days of unusual meteor activity.

Meteorology.

Particular efforts should be made to carry out an intensified program on the RGD -- each Wednesday, UT. A desirable goal would be the scheduling of meteorological rocketsondes, ozone sondes and radiometer sondes on these days, together with maximum-altitude rawinsonde ascents at both 0000 and 1200 UT.

During **WGI and STRATWARM Alert Intervals**, intensified programs are also desirable, preferably by the implementation of RGD-type programs (see above) on Mondays and Fridays, as well as on Wednesdays.

Global Atmosphere Watch (GAW).

The World Meteorological Organization (WMO) Global Atmosphere Watch (GAW) integrates many monitoring and research activities involving measurement of atmospheric composition, and serves as an early warning system to detect further changes in atmospheric concentrations of greenhouse gases, changes in the ozone layer and in the long range transport of pollutants, including acidity and toxicity of rain as well as of atmospheric burden of aerosols (dirt and dust particles). Contact WMO, 7 bis avenue de la Paix, P.O. Box 2300, CH-1211 Geneva 2, Switzerland or wmo@wmo.int.

Solar Phenomena.

Observatories making specialized studies of solar phenomena, particularly using new or complex techniques, such that continuous observation or reporting is impractical, are requested to make special efforts to provide to WDCs data for solar eclipse days, RWDs and during PROTON/FLARE ALERTS. The attention of those recording solar noise spectra, solar magnetic fields and doing specialized optical studies is particularly drawn to this recommendation.

Variability of the Sun and Its Terrestrial Impact (VarSITI).

Program within the SCOSTEP (Scientific Committee on Solar-Terrestrial Physics): 2014-2018. The VarSITI program will strive for international collaboration in data analysis, modeling, and theory to understand how the solar variability affects Earth. The VarSITI program will have four scientific elements that address solar terrestrial problems keeping the current low solar activity as the common thread: SEE (Solar evolution and Extrema), MiniMax24/ISEST (International Study of Earth-affecting Solar Transients), SPeCIMEN (Specification and Prediction of the Coupled Inner-Magnetospheric Environment), and ROSMIC (Role Of the Sun and the Middle atmosphere/thermosphere/ionosphere In Climate). Contact is Prof. Marianna Shepherd (mshepher@yorku.ca), President of SCOSTEP. Co-chairs are Katya Georgieva (SRTI, Bulgaria) and Kazuo Shiokawa (STEL, Japan).

ILWS (International Living With a Star) International effort to stimulate, strengthen, and coordinate space research to understand the governing processes of the connected Sun-Earth System as an integrated entity. Contact info@ilwsonline.org.

ISWI (International Space Weather Initiative) -- a program of international cooperation to advance space weather science by a combination of instrument deployment, analysis and interpretation of space weather data from the deployed instruments in conjunction with space data, and communicate the results to the public and students. The goal of the ISWI is to develop the scientific insight necessary to understand the science, and to reconstruct and forecast near-Earth space weather. This includes instrumentation, data analysis, modelling, education, training, and public outreach. Contact Dr. N. Gopalswamy at nat.gopalswamy@nasa.gov.

Space Research, Interplanetary Phenomena, Cosmic Rays, Aeronomy.

Experimenters should take into account that observational efforts in other disciplines tend to be intensified on the days marked on the Calendar, and schedule balloon and rocket experiments accordingly if there are no other geophysical reasons for choice. In particular it is desirable to make rocket measurements of ionospheric characteristics on the same day at as many locations as possible; where feasible, experimenters should endeavor to launch rockets to monitor at least normal conditions on the Quarterly World Days (QWDs) or on RWDs, since these are also days when there will be maximum support from ground observations. Also, special efforts should be made to assure recording of telemetry on QWDs and Airglow and Aurora Periods of experiments on satellites and of experiments on spacecraft in orbit around the Sun.

Meteor showers.

Of particular interest are both predicted and unexpected showers from the encounter with recent dust ejecta of comets (meteor outbursts). The period of activity, level of activity, and magnitude distributions need to be determined in order to provide ground truth for comet dust ejection and meteoroid stream dynamics models. Individual orbits of meteoroids can also provide insight into the ejection circumstances. If a new (1-2 hour duration) shower is observed due to the crossing of the 1-revolution dust trail of a (yet unknown) Earth threatening long-period comet, observers should pay particular attention to a correct determination of the radiant and time of peak activity in order to facilitate predictions of future encounters. Observations of meteor outbursts should be reported to the I.A.U. Minor Planet Center (mpc@cfa.harvard.edu) and International Meteor Organization (visual@imo.net). The activity curve, mean orbit, and particle size distribution of minor annual showers need to be characterised in order to understand their relationship to the dormant comets among near-Earth objects. Annual shower observations should be

reported to national meteor organizations, or directly to the International Meteor Organization. Meteoroid orbits are collected by the IAU Meteor Data Center.

The International Space Environment Service (ISES) is a space weather service organization currently comprised of 17 Regional Warning Centers around the globe, 4 Associate Warning Centers, and one Collaborative Expert Center (European Space Agency). ISES is a Network Member of the International Council for Science World Data System (ICSU-WDS) and collaborates with the World Meteorological Organization (WMO) and other international organizations, including the Committee on Space Research (COSPAR), the International Union of Radio Science (URSI), and the International Union of Geodesy and Geophysics (IUGG). The mission of ISES is to improve, to coordinate, and to deliver operational space weather services. ISES is organized and operated for the benefit of the international space weather user community. ISES members share data and forecasts among the Regional Warning Centers (RWCs) and provide space weather services to users in their regions. The RWCs provide a broad range of services, including: forecasts, warnings, and alerts of solar, magnetospheric, and ionospheric conditions; extensive space environment data; customer-focused event analyses; and long-range predictions of the solar cycle. While each RWC concentrates on its own region, ISES serves as a forum to share data, to exchange and compare forecasts, to discuss user needs, and to identify the highest priorities for improving services.

ISES works in close cooperation with the World Meteorological Organization, recognizing the mutual interest in global data acquisition and information exchange, in common application sectors, and in understanding and predicting the coupled Earth-Sun environment.

This Calendar for 2016 has been drawn up by Dr. R. A. D. Fiori of the ISES Steering Committee, in association with spokesmen for the various scientific disciplines in the Scientific Committee on Solar-Terrestrial Physics (SCOSTEP), the International Association of Geomagnetism and Aeronomy (IAGA), URSI and other ICSU organizations. Similar Calendars are issued annually beginning with the IGY, 1957-58, and are published in various widely available scientific publications. PDF versions of the past calendars are available online.

Published for the International Council of Scientific Unions and with financial assistance of UNESCO for many years. Copies are available upon request to ISES Director, Dr. Terry Onsager, NOAA Space Weather Prediction Center, 325 Broadway, Boulder, CO, 80305, USA, telephone +1-303-497-5713, FAX +1-303-497-3645, e-mail Terry.Onsager@noaa.gov, or ISES Secretary for World Days, Dr. Robyn Fiori, Geomagnetic Laboratory, Natural Resources Canada, 2617 Anderson Road, Ottawa, Ontario, Canada, K1A0E7, telephone +1-613-837-5137, e-mail robyn.fiori@canada.ca. Beginning with the 2008 Calendar, all calendars are available only in digital form.

List of URSI Officials

Honorary President

Prof. J. Van Bladel (Belgium)

Board of Officers

President : Prof. P. Cannon (U.K.)
Past President : Dr. P. Wilkinson (Australia)
Vice-Presidents : Prof. S. Ananthakrishnan (India)
Prof. M. Ando (Japan)
Prof. Y. Antar (Canada)
Prof. U. Inan (U.S.A.)
Secretary General: Prof. P. Lagasse (Belgium)

URSI Secretariat

Secretary General: Prof. P. Lagasse
Assistant S.G. : Prof. P. Van Daele
Dr. W.R. Stone (Publications & GASS)
Prof. K. Kobayashi (AP-RASC)
Prof. P.L.E. Uslenghi (AT-RASC)
Secretary : Ms. I. Heleu
Ms. I. Lievens

Standing Committees

Standing Publications Committee

Chair : Dr. W.R. Stone (U.S.A.)
Members : Prof. P. Cannon (U.K.)
Prof. P. Lagasse (Belgium)
Prof. S.C. Reising (USA)
Prof. T. Tanzi (France)
Dr. P. Wilkinson (Australia)

AP-RASC Standing Committee

Chair : Prof. K. Kobayashi (Japan)
Members : Prof. M. Ando (Japan)
Prof. A. Bhattacharyya (India)
Prof. P. Cannon (U.K.)
Prof. P. Lagasse (Belgium)

Prof. L.C. Lee (China SRS)
Prof. S. Nam (South Korea)
Prof. P. Smith (Australia)
Dr. W.R. Stone (USA)
Prof. N. Thomson (New Zealand)
Prof. P. Van Daele (Belgium)
Dr. P. Wilkinson (Australia)
Dr. J. Wu (China CIE)

Standing Committee on Young Scientists

Chair : Prof. F. Lefevre (France)
Members : Mr. J. Hamelin (France)
Prof. P. Kaufman (Brazil)
Prof. K. Kobayashi (Japan)
Prof. S. Reising (U.S.A.)
Prof. K. Schlegel (Germany)
Prof. P. Van Daele (Belgium)

Past Chairs Advisory Committee (PCAC)

Chair : Prof. A. Van Deursen (the Netherlands)
Members : Prof. P. Cannon (U.K.)
Dr. W.A. Davis (U.S.A.)
Prof. J. Jonas (South Africa)
Prof. P. Lagasse (Belgium) (ex officio)
Dr. R.H. Lang (U.S.A.)
Prof. M. Luise (Italy)
Prof. G. Manara (Italy)
Prof. J.D. Mathews (U.S.A.)
Prof. O. Santolik (Czech Republic)
Prof. M. Taki (Japan)
Dr. S. Tedjini (France)
Prof. P. Van Daele (Belgium)

URSI ad hoc groups

Scientific Programme XXXIIth General Assembly

Coordinator : Dr. Y. Yan (China CIE)
Associate Coordinator : Dr. F. Labeau (Canada)

Scientific Commissions

Commission A : Electromagnetic Metrology

Chair : Prof. Y. Koyama (Japan)
Vice-Chair : Dr. P. Tavella (Italy)
ECR : Dr. P.M. Duarte Cruz (Portugal)

Official Members :

Australia : Prof. M.E. Tobar
Austria :
Belgium : Prof. E. Van Lil
Brazil : Prof. L. Alencar
Bulgaria : Prof. A. Lazarov
Canada : Dr. L. Shafai
China CIE (Beijing) : Dr. M. Liu
China SRS (Taipei) : Prof. D.C. Chang
Czech Rep.: Dr. J. Roztocil
Denmark:
Egypt : Prof. M. Fahmy
Finland : Dr. A. Manninen
France : Dr. C. Zerrouki
Germany : Dr. O.T. Schrader
Greece : Prof. G.A. Kyriacou
Hungary : Prof. M. Kenderessy
India : Dr. A. Sen Gupta
Ireland : Prof. P. Murphy
Israel : Dr. J. Halevy-Politch
Italy : Dr. L. Callegaro
Japan : Prof. M. Musha
Netherlands :
New Zealand : Dr. T.R. Armstrong
Nigeria : Dr. T.C. Chineke
Norway : Dr. H.A. Froystein
Peru : Ing. M. Mayorga Montoya
Poland : Prof. R. Katulski
Portugal : Prof. N.B. Carvalho
Russia : Dr. V.N. Zhogun
Saudi Arabia : Dr. A. Al-Rajehi
Slovakia : Prof. I. Kneppo
South Africa :
South Korea : Dr. J.H. Kim
Spain : Prof. E. Martin Rodriguez
Sweden : Dr. J. Carlsson
Switzerland :
Turkey : Dr. F. Ustüner
Ukraine :
United Kingdom : Dr. T. Hong Lo
U.S.A. : Dr. S. Weiss

Observers :

Argentina: Ing. H.F. Mazza
Chile : Prof. F. Noel
Iraq:
Singapore:

Commission B : Fields and Waves

Chair : Prof. A. Sihvola (Finland)
Vice-Chair : Prof. K. Kobayashi (Japan)
ECR : Dr. Lianlin Li (China CIE)

Official Members :

Australia : Prof. P. Smith
Austria : Dr. H. Arthaber
Belgium : Prof. H. Rogier
Brazil : Prof. E. Costa
Bulgaria : Prof. E. Ferdinandov
Canada : Dr. M. Clénet
China CIE (Beijing) : Dr. D. Su
China SRS (Taipei) : Prof. H.C. Chang
Czech Rep. : Prof. Z. Skvor
Denmark: Prof. O. Breinbjerg
Egypt : Prof. H.M. El-Hennawy
Finland : Prof. A. Sihvola
France : Dr. A. Priou
Germany : Prof. Dr. Ir. Schuhmann
Greece : Prof. T. Tsiboukis
Hungary : Dr. Gy. Veszely
India : Dr. D. Guha
Ireland : Prof. V.F. Fusco
Israel : Prof. R. Kastner
Italy : Prof. M. Pastorino
Japan : Prof. T. Uno
Netherlands : Prof. Dr. A. Yarovoy
New Zealand : Dr. R. Vaughan
Nigeria : Dr. V.U. Ckukwuma
Norway : Prof. U. Osterberg
Peru : Dr. M. Yarlequé Medena
Poland : Prof. A. Kucharski
Portugal : Prof. C. Peixeiro
Russia : Dr. A.P. Kurochkin
Saudi Arabia :
Slovakia : Prof. L. Sumichrast
South Africa : Prof. A.R. Clark
South Korea : Prof. S. Nam
Spain : Prof. F. Medina-Mena
Sweden : Prof. D. Sjöberg
Switzerland : Prof. Juan Mosig
Turkey : Dr. I. Aksun
Ukraine : Prof. O.A. Tretyakov
United Kingdom : Dr. A. Alomainy
U.S.A. : Prof. J.L. Volakis

Observers :

Argentina: Prof. V. Trainotti
Chile : Prof. B. Jacard
Iraq:
Singapore : Dr. H. Zhao

Commission C : Radiocommunication Systems and Signal Processing

Chair : Prof. S. Salous (U.K.)
Vice-Chair : Dr. A. Zaghoul (U.S.A)
ECR : Dr. Ruisi He (Belgium)

Official Members :

Australia : Prof. A.J. Parfitt
Austria : Prof. O. Koudelka
Belgium : Prof. L. Vandendorpe
Brazil : Prof. M. Alencar
Bulgaria :
Canada : Dr. L. Le
China CIE (Beijing) : Dr. R. Tao
China SRS (Taipei) : Dr. Y-K Tu
Czech Rep. : Prof. D. Bielek
Denmark : Egypt : Prof. S.E. El-Khamy
Egypt:
Finland : Prof. R. Wichman
France : Prof. M. Terre
Germany : Prof. Dr. J. Götze
Greece : Prof. N. Kalouptsidis
Hungary : Dr. L. Nagy
India : Dr. M.V.S.N. Prasad
Ireland : Dr. M. O'Droma
Israel : Dr. S. Litsyn
Italy : Prof. S. Buzzi
Japan : Prof. N. Kikuma
Netherlands : Dr. Ir. M.J. Bentum
New Zealand : Dr. P.T. Gough
Nigeria : Dr. S.E. Falodun
Norway : Prof. B. Forssell
Peru : Ing. D. Chávez Muñoz
Poland : Prof. P. Szulakiewicz
Portugal : Prof. Dr. A. Rodrigues
Russia : Dr. A.B. Shmelev
Saudi Arabia :
Slovakia : Prof. P. Farkas
South Africa : Prof. B.T.J. Maharaj
South Korea : Prof. J. Chun
Spain : Prof. M. Sierra- Castañer
Sweden : Mr. K.A. Markstrom
Switzerland : Prof. M. Rubinstein
Turkey : Dr. E. Panayirci
Ukraine : Prof. V.V. Danilov
United Kingdom : Dr. D. Laurenson
U.S.A. : Dr. G.H. Huff

Observers :

Argentina: Prof. A. Quijano
Chile : Dr. R. Feick
Iraq:
Singapore:

Commission D : Electronics and Photonics

Chair : Prof. G. Steinmeyer (Germany)
Vice-Chair : Dr. A. Georgiadis (Spain)
ECR : Prof. A. Vena (France)

Official Members :

Australia : Prof. A. Parker
Austria : Prof. W. Bösch
Belgium : Prof. P. Van Daele
Brazil : Prof. H.J. Kalinowski
Bulgaria : Prof. M. Nenchev
Canada : Dr. C. Caloz
China CIE (Beijing) : Dr. H. Guo
China SRS (Taipei) : Prof. Y.-K. Su
Czech Rep. : Prof. O. Wilfert
Denmark :
Egypt : Prof. Dr. D. A. Khalil
Finland : Assoc. Prof. Z. Sun
France : Prof. C. Maneux
Germany : Prof. Dr. D. Killat
Greece : Dr. Em. Kriezis
Hungary : Prof. V. Szekely
India : Prof. A. Ramakrishna
Ireland : Prof. T. Brazil
Israel : Prof. Y. Nemirovsky
Italy : Prof. S. Selleri
Japan : Prof. K. Tsukamoto
Netherlands : Ir. F.L.M. Van Den Bogaart
New Zealand :
Nigeria : Dr. S.O. Azi
Norway : Prof. A. Rönnekleiv
Peru : Mr. P. Paz Retuerto
Poland : Prof. A. Napieralski
Portugal : Prof. L. Sousa
Russia : Prof. V. Kuznetsov
Saudi Arabia :
Slovakia : Dr. J. Novak
South Africa : Prof. S. Sinha
South Korea : Prof. J-S Rieh
Spain : Dr. I. Molina Fernandez
Sweden : Prof. A. Rydberg
Switzerland : Dr. C. Dehollain
Turkey : Dr. H. Kulah
Ukraine : Prof. V.G. Litovchenko
United Kingdom : Dr. N. Johnson
U.S.A. : Prof. Z. Popovic

Observers :

Argentina: Dr. M. Garavaglia
Chile :
Iraq:
Singapore: Dr. J. Png Ching Eng

Commission E : Electromagnetic Environment and Interference

Chair : Dr. D. Giri (U.S.A.)
Vice-Chair : Prof. F. Gronwald (Germany)
ECR : Dr. G. Gradoni (U.K.)

Official Members :

Australia : Dr. J. O'Sullivan
Austria :
Belgium : Prof. G. Vandenbosch
Brazil : Prof. J-P Raulin
Bulgaria : Prof. E. Nickolov
Canada : Prof. P. Mojabi
China CIE (Beijing) : Dr. Y. Wen
China SRS (Taipei) : Dr. K.-H. Lin
Czech Rep. : Dr. M. Svoboda
Denmark : Prof. O. Breinbjerg
Egypt : Prof. E.M. Saad
Finland : Dr. A. Viljanen
France : Prof. V. Deniau
Germany : Dr. F. Sabath
Greece : Prof. C. Capsalis
Hungary : Dr. G. Varju
India : Prof. S. Ananthakrishnan
Ireland : Dr. K. Mc Carthy
Israel : Mr. O. Hartal
Italy : Prof. S. Pignari
Japan : Prof. O. Wada
Netherlands : Dr. A.P.J. Van Deursen
New Zealand :
Nigeria : Prof. M. Onuu
Norway : Dr. J. Tjelta
Peru : Dr. C.V. Velasquez-Lopez
Poland : Prof. P. Slobodzian
Portugal : Eng. J.P. Borrego
Russia : Prof. V.I. Larkina
Saudi Arabia :
Slovakia : Prof. V. Smiesko
South Africa : Prof. H.C. Reader
South Korea : Prof. W. Nah
Spain : Dr. J.D. Gallego Pujol
Sweden : Dr. K. Wiklundh
Switzerland : Mr. F. Rachidi
Turkey : Dr. S. Demir
Ukraine : Prof. N.T. Cherpak
United Kingdom : Dr. M. Fullekrug
U.S.A. : Dr. L. Cohen

Observers :

Argentina: Eng. O.M. Beunza
Chile :
Iraq:
Singapore:

Commission F : Wave Propagation and Remote Sensing

Chair : Dr. S. Paloscia (Italy)
Vice-Chair : Prof. V. Chandrasekar (U.S.A.)
ECR : Dr. M. Kurum (Turkey)

Official Members :

Australia : Ms. C. Wilson
Austria : Dr. M. Schönhuber
Belgium : Prof. P. Sobieski
Brazil : Prof. M.S. de Assis
Bulgaria : Prof. D. Radev
Canada : Prof. D. Michelson
China CIE (Beijing) : Prof. Q. S. Dong
China SRS (Taipei) : Prof. K. S. Chen
Czech Rep. : Assoc. Prof. S. Zvanovec
Denmark : Prof. N. Skou
Egypt : Prof. M.A. Abuldahab
Finland : Prof. M.T. Hallikainen
France : Dr. M. Dechambre
Germany : Prof. Dr. M. Chandra
Greece : Prof. D.P. Chrissoulidis
Hungary : Dr. R. Seller
India : Prof. A. Maitra
Ireland : Dr. C. Brennan
Israel : Prof. A. Cohen
Italy : Prof. C. Capsoni
Japan : Prof. Y. Maekawa
Netherlands : Prof. L.P. Lighthart
New Zealand : Dr. E.M. Poulter
Nigeria : Prof. M.O. Ajewole
Norway : Dr. J. F. Hjelmstad
Peru : Dr. M.F. Sarango
Poland : Dr. K. Kulpa
Portugal : Prof. Dr. J.C. da Silva Neves
Russia : Dr. A.A. Chukhlantsev
Saudi Arabia : Dr. A. Al-Rajehi
Slovakia : Dr. V. Stofanik
South Africa : Dr. A. Mishra
South Korea : Prof. Y. Oh
Spain : Prof. G.J. Molina Cuberos
Sweden : Dr. J.F. Johansson
Switzerland : Mr. D. Vergeres
Turkey : Dr. S. Gezici
Ukraine : Prof. G.P. Kulemin
United Kingdom : Dr. D. Bebbington
U.S.A. : Dr. M.H. Newkirk

Observers :

Argentina: Dr. D.A. Gagliardini
Chile : Mr. R. Aguilera
Iraq:
Singapore:

Commission G : Ionospheric Radio and Propagation

Chair : Prof. I. Stanislawska (Poland)
Vice-Chair : Prof. P. Doherty (U.S.A.)
ECR : Dr. S. Datta - Barua (U.S.A.)

Official Members :

Australia : Dr. P. Wilkinson
Austria : Prof. K.M. Torkar
Belgium : Mr. R. Warnant
Brazil : Dr. I.S. Batista
Bulgaria : Dr. N. Kilifarska
Canada : Prof. P.T. Jayachandran
China CIE (Beijing) : Dr. Z. Zhao
China SRS (Taipei) : Prof. Y.H. Chu
Czech Rep. : Dr. J. Boska
Denmark : Prof. P. Høeg
Egypt : Prof. S. Zain El-Deen
Finland : Dr. P. Aikio
France : Dr. F. Pitout
Germany : Dr. M. Förster
Greece : Prof. J. Kanellopoulos
Hungary : Dr. P. Bencze
India : Dr. A.K. Patra
Ireland : Prof. M.C. Sexton
Israel : Dr. Z. Houminer
Italy : Dr. M. Materassi
Japan : Prof. M. Yamamoto
Netherlands : Dr. R.P. Cerdeira
New Zealand : Prof. W.J. Baggaley
Nigeria : Prof. A.B. Rabi
Norway : Prof. A. Brekke
Peru : Dr. J.L. Chau
Poland : Dr. I. Stanislawska
Portugal : Cap. T.E. Bolas
Russia : Prof. Yu. Ya. Ruzhin
Saudi Arabia : Dr. A. Al-Rajehi
Slovakia : Dr. R. Kudela
South Africa : Dr. Z. Katamzi
South Korea : Prof. S-H Bae
Spain : Prof. J.L. Pijoan Vidal
Sweden : Dr. I. Haggström
Switzerland :
Turkey : Dr. F. Arıkan
Ukraine : Prof. Y.M. Yampolsky
United Kingdom : Prof. F. Honary
U.S.A. : Dr. S. Close

Observers :

Argentina: Prof. S.M. Radicella
Chile : Dr. A. Foppiano
Iraq:
Singapore:

Commission H : Waves in Plasmas

Chair : Dr. O. Santolik (Czech Republic)
Vice-Chair : Dr. J. Lichtenberger
ECR : Dr. W. Li (U.S.A.)

Official Members :

Australia : Assoc. Prof. C. Waters
Austria : Prof. H. Rucker
Belgium : Dr. V. Pierrard
Brazil : Dr. J.A. Bittencourt
Bulgaria : Prof. I. Zhelyazkov
Canada : Prof. P.T. Jayachandran
China CIE (Beijing) : Dr. J. Cao
China SRS (Taipei) : Prof. L. C. Lee
Czech Rep. : Assoc. Prof. O. Santolik
Denmark : Prof. J.J. Rasmussen
Egypt : Prof. I.I. Mahmoud
Finland : Prof. R. Vainio
France : Dr. P. Galopeau
Germany : Apl. Prof. Dr. G. Mann
Greece : Prof. J.L. Vomvoridis
Hungary : Prof. C. Ferencz
India : Dr. G.S. Lakhina
Ireland : Prof. M.C. Sexton
Israel : Prof. M. Mond
Italy : Dr. G. Granucci
Japan : Prof. Y. Kasahara
Netherlands :
New Zealand : Prof. C.J. Rodger
Nigeria :
Norway : Prof. J. Trulsen
Peru : Dr. W.R. Guevara Day
Poland : Prof. H. Rothkaehl
Portugal : Prof. M.E. Manso
Russia : Dr. Y.V. Chugunov
Saudi Arabia :
Slovakia :
South Africa : Dr. A.B. Collier
South Korea : Prof. C. Chol
Spain : Prof. M. Sancho Ruiz
Sweden : Dr. T. Leyser
Switzerland :
Turkey : Dr. I. Unal
Ukraine : Prof. A.G. Zagorodniy
United Kingdom : Prof. M.W. Dunlop
U.S.A. : Dr. A.V. Streltsov

Observers :

Argentina: Prof. A. Giraldez
Chile : Prof. L. Gomberoff
Iraq:
Singapore:

Commission J : Radio Astronomy

Chair : Prof. W. Baan (the Netherlands)

Vice-Chair : Dr. R. Bradley (U.S.A.)

ECR (Chair) : Dr. S. Wijnholds (Netherlands)

Official Members :

Australia :
Austria : Prof. H. Rucker
Belgium : Dr. F. Clette
Brazil : Prof. P. Kaufmann
Bulgaria : Prof. P. Velinov
Canada : Dr. S. Claude
China CIE (Beijing) : Dr Y. Yan
China SRS (Taipei) : Prof. T-P Ho
Czech Rep. : Dr. K. Jiricka
Denmark : Prof. J. Knude
Egypt : Prof. Dr. M. El-Hadidi
Finland : Dr. M. Tornikoski
France : Mr. A. Deschamps
Germany : Dr. A. Kraus
Greece : Prof. J.H. Seiradakis
Hungary : Prof. I. Fejes
India : Prof. P. Janardhan
Ireland : Prof. A. Murphy
Israel : Dr. N. Brosch
Italy : Dr. R. Ambrosini
Japan : Prof. K. Fujisawam
Netherlands : Prof. A. Van Ardenne
New Zealand : Prof. S. Gulyaev
Nigeria : Dr. F.B. Sigalo
Norway : Prof. P. Lilje
Peru : Dr. J. Heraud
Poland : Prof. M. Szymczak
Portugal : Prof. L. Cupido
Russia : Dr. I.I. Zinchenko
Saudi Arabia : Dr. A. Al-Rajehi
Slovakia :
South Africa : Prof. J.L. Jonas
South Korea : Dr. S-T Han
Spain : Dr. C.M. Gutierrez de la Cruz
Sweden : Dr. M. Lindqvist
Switzerland :
Turkey : Prof. F.F. Özeren
Ukraine : Prof. A.A. Konovalenko
United Kingdom : Dr. K. Grainge
U.S.A. : Dr. D. DeBoer

Observers :

Argentina : Dr. E. Bajaja
Chile : Prof. H. Alvarez
Iraq:
Singapore:

Commission K : Electromagnetics in Biology & Medicine

Chair : Prof. J. Wiart (France)

Vice-Chair : Dr S. Chung (South Korea)

ECR : Dr. P. Mojabi (Canada)

Official Members :

Australia :
Austria : Prof. N. Leitgeb
Belgium : Prof. A.I. Francois
Brazil :
Bulgaria : Prof. A. Slavova-Popivanova
Canada : Prof. M. Okoniewski
China CIE (Beijing) : Dr. J. Tian
China SRS (Taipei) : Prof. J-S Lee
Czech Rep. : Prof. J. Vrba
Denmark : Prof. J. B. Andersen
Egypt : Prof. Dr. H.A. Al-Mikati
Finland : Prof. R. Ilmoniemi
France : Dr. C. Person
Germany : Dr. Ing. L.O. Fichte
Greece : Prof. N.K. Uzunoglu
Hungary : Dr. G. Thuroczy
India : Assoc. Prof. R. Paulraj
Ireland : Dr. M. Ammann
Israel : Prof. R. Korenstein
Italy : Prof. G. D'Inzeo
Japan : Prof. K. Ito
Netherlands : Prof. A.P.M. Zwamborn
New Zealand :
Nigeria : Prof. A.M. Arogunjo
Norway : Prof. B.A.J. Angelsen
Peru : Ing. L. Vilcahuaman Cajacuri
Poland : Prof. A. Krawczyk
Portugal : Prof. P. Clemente
Russia : Dr. O.V. Betskiy
Saudi Arabia :
Slovakia : Prof. I. Frollo
South Africa : Mr. R. Hubbard
South Korea : Prof. Y.M. Gimm
Spain : Prof. M.E. Lopez Martin
Sweden : Prof. Y. Hamnerius
Switzerland : Prof. N. Kuster
Turkey : Dr. A. Köksal
Ukraine : Prof. Y. O. Zozulya
United Kingdom : Dr. M.P. Robinson
U.S.A. : Prof. M. Moghaddam

Observers :

Argentina : Prof. V.H. Padula-Pintos
Chile :
Iraq:
Singapore

Working Groups 2014-2017

D.1 RFID Technologies and Privacy of Data

Chair: Dr. S. Tedjini (France)

Vice-Chair: Dr. G. Marrocco (Italy)

E.1 Terrestrial and Planetary Electromagnetic Noise Environment

Co-Chairs: Y. Hobara (Japan), K. Hattori (Japan),

A.P. Nickolaenko (Ukraine), C. Price (Israel)

E.2 Intentional Electromagnetic Interference

Co-Chairs: M. Bäckström (Sweden) and W. Radasky (USA)

E.3 High Power Electromagnetics

Co-Chairs: R. L. Gardner (USA) and F. Sabath (Germany)

E.4 Lightning Discharges and Related Phenomena

Co-Chairs: S. Yoshida (Japan) and Dr. V. Rakov (USA)

E.5 Interaction with and Protection of Complex Electronic Systems

Co-Chairs: J-P. Parmentier (France), F. Gronwald (Germany), and H. Reader (South Africa)

E.6 Spectrum Management

Chair: J. P. Borrego (Portugal)

E.7 Geo-Electromagnetic Disturbances and Their Effects on Technological Systems

Chair: A. Viljanen (Finland)

E.8 Electromagnetic Compatibility in Wired and Wireless Systems

Co-Chairs: F. Rachidi (Switzerland) and A. Zeddani (France)

E9. Stochastic Techniques in EMC

Co-Chairs: L. Arnaut (UK), S. Pignari (Italy), and R. Serra (Netherlands)

F.1 Education and Training in Remote Sensing and Related Aspects of Propagation/Next-Generation Radar Remote Sensing

Chair: M. Chandra (Germany)

Co-Chairs: J. Isnard (France), W. Keydel (Germany), E. Schweicher (Belgium)

G.1 Ionosonde Network Advisory Group (INAG)

Chair: I. Galkin (USA)

Vice-Chairs: J. B. Habarulema (South Africa), Dr. B. Ning (China CIE)

INAG Bulletin Editor: P. Wilkinson (Australia)

G.2 Studies of the Ionosphere Using Beacon Satellites

Chair: P. Doherty (USA)

Honorary Chair: R. Leitinger (Austria)

G.3 Incoherent Scatter

Chair: M. McCready (USA)

Vice-Chair: I. McCrea (UK)

K.1 Stochastic Modeling for Exposure Assessment

Co-Chairs: Dr. J. Wiart (France) and Dr. T. Wu (China CIE)

Joint Working Groups

EFGHJ. RFI Mitigation and Characterization

Chair for Commission E: F. Gronwald (Germany)

Chairs for Commission F: A. K. Mishra (South Africa), D. Le Vine (USA)

Chair for Commission G: T. Bullett (USA)

Chair for Commission H: H. Rothkaehl (Poland)

Chairs for Commission J: R. Bradley (USA), W. Baan (Netherlands)

EGH. Seismo Electromagnetics (Lithosphere-Atmosphere-Ionosphere Coupling)

Chair for Commission E: Y. Hobara (Japan)

Chair for Commission G: S. Pulnits (Russia)

Chair for Commission H: H. Rothkaehl (Poland)

EHG. Solar Power Satellites

Chair: H. Matsumoto (Japan)

Co-Chair for Commission E: J. Gavan (Israel)

Co-Chair for Commission H: K. Hashimoto (Japan)

Co-Chair for Commission G: K. Schlegel (Germany)

FG. Atmospheric Remote Sensing Using Satellite Navigation Systems

Co-Chairs for Commission F: N. Floury (Netherlands)

Chair for Commission G: C. Mitchell (UK)

GF. Middle Atmosphere

Chair for Commission F: Dr. F. Marzano (Italy)

Co-Chairs for Commission G: J. L. Chau (Peru), E. Kudeki (USA)

GH. Active Experiments in Plasmas

Chair for Commission G: T. Pedersen (USA)
Chair for Commission H: M. Kosch (South Africa)

Inter-Commission Data Committee

Chair: S. Wijnholds (the Netherlands)

HJ. Computer Simulations in Space Plasmas

Co-Chairs for Commission H: Y. Omura (Japan) and B. Lembege (France)
Chair for Commission J: K. Shibata (Japan)

Inter-Union Working Groups

URSI/IAGA VLF/ELF Remote Sensing of the Ionosphere and Magnetosphere (VERSIM)

Chair for URSI (Commissions E, G, H): M. Clilverd (UK)
IAGA Chair: J. Bortnik (USA)

URSI/COSPAR on International Reference Ionosphere (IRI)

Chair: D. Altadill (Spain)
Vice-Chair for URSI: V. Truhlik (Czech Republic) Vice-Chair for COSPAR: S. Watanabe (Japan) Secretary: D. Bilitza (USA)

URSI/IUCAF Inter-Commission Working Group on Radio Science Services

Chair for IUCAF: Dr. W. Van Driel (France)(ex officio)

URSI/IAU Inter-Union Working Group on the History of Radio Astronomy

Chairs: R. Schilizzi (UK), R. Wielebinski (Germany)

URSI Member Committees

AUSTRALIA	President : Prof. P. Smith Secretary : Ms. M. O'Brien	NEW ZEALAND	President : Prof. N.R. Thomson Secretary : Ms. J. Reid
AUSTRIA	President : Prof. H. Rucker	NIGERIA	President : Prof. I.A. Adimula Secretary : Dr. J.S. Ojo
BELGIUM	President : Prof. C. De Mol Secretary : Dr. V. Pierrard	NORWAY	President : Prof. J. Trulsen Secretary : Ms. Brynildsen
BRAZIL	President : Prof. M.S. Assis Secretary : Prof. M.T.M. Rocco Giraldi	PERU	President : Dr. J. Heraud Secretary : Dr. E. Pacheco
BULGARIA	President : TBD Secretary : Prof. M. Nenchev	POLAND	President : Prof. J. Modelski Secretary : Dr. A. Witczak
CANADA	President : Dr. F. Prato Secretary : Dr. A.D. Gray	PORTUGAL	President : Eng. M.L. Mendes Secretary : Ms. H.P. Prazeres
CHINA (CIE)	President : Dr. J. Wu Secretary : Mr. R-H Lin	RUSSIA	President : Dr. Yu. V. Gulyaev Secretary : Dr. G.I. Chukhray
CHINA (SRS)	President : Prof. L-C Lee Secretary : Prof. K-S Chen	SAUDI ARABIA	President : Dr. M.I. Suwaiyel Secretary : Mr. M. Al-Badrani
CZECH REP.	President : Prof. M. Mazanek Secretary : Assoc. Prof. O. Fiser	SLOVAKIA	President : Dr. V. Stofanik Secretary : Dr. Z. Krajcuskova
DENMARK	President : Prof. O. Breinbjerg	SOUTH AFRICA	President : Dr. L-A McKinnell Secretary : Ms. L. Ngwenya
EGYPT	President : Prof. S.E. El-Khamy Secretary : Prof. E.M. Saad	SOUTH KOREA	President : Prof. S. Nam Secretary : Prof. S.O. Park
FINLAND	President : Prof. A. Sihvola Secretary : Dr. H. Wallén	SPAIN	President : Prof. F. Ares-Pena Secretary : Prof. J. Rodriguez-Gonzales
FRANCE	President : Dr. S. Tedjini Secretary : Prof. A. Sibille	SWEDEN	President : Prof. A. Pellinen-Wannberg Secretary : Mr. C.-H. Walde
GERMANY	President : Prof. W. Mathis Secretary : Dr. E. Bogenfeld	SWITZERLAND	President : Prof. F. Rachidi
GREECE	President : Prof. N.K. Uzunoglu Secretary : Dr. T. Samaras	TURKEY	President : Dr. A. Altintas Secretary : Dr. B. Saka
HUNGARY	President : Prof. L. Zombory Secretary : Dr. L. Nagy	UKRAINE	President : Prof. A.N. Pogorily Secretary : Dr. O.M. Kuzmak
INDIA	President : Dr. G.S. Lakhina Secretary : Dr. A. Moitra	UNITED KINGDOM	President : Dr. I. Glover Secretary : Prof. M. Warrington
IRELAND	President : Dr. M. O'Droma Secretary : Ms. Y. Graham	U.S.A.	President : Prof. D. Jackson Secretary : Prof. S. Rengarajan
ISRAEL	President : Prof. E. Heyman Secretary : Prof. R. Kastner		
ITALY	President : Prof. R. Sorrentino Secretary : Dr. P. Tavella		
JAPAN	President : Prof. K. Kobayashi Secretary : Prof. S. Yagitani		
NETHERLANDS	President : Dr. Ir. M.J. Bentum Secretary : Dr. R. Serra		
		<i>Associate Member Committees</i>	
		ARGENTINA	President : Mr. N.A. Dominguez Secretary : Ing. A. Garbini
		CHILE	President : Prof. B. Jacard
		IRAQ :	President : Dr. Eng. S.B. Sadkhan
		SINGAPORE:	President : Dr. J. Png Ching Eng

Representatives of Scientific Organizations

COSPAR (Committee on Space Research):
Prof. I. Stanislawska (Poland)

IAU (International Astronomical Union):
Dr. R. Schilizzi (UK)

ICG (International Committee on Global Navigation Satellite Systems):
Prof. P. Doherty (USA)

ICSU (International Council of Scientific Unions):
Prof. P. Cannon (UK)
Dr. P. Wilkinson (Australia)

ICSU World Data System:
Dr. D. Bilitza (USA)

ISES (International Space Environment Service):
Dr. M. Terkildsen (Australia)

ISPRS (International Society for Photogrammetry & Remote Sensing):
Prof. T. J. Tanzi

IUCAF (Scientific Committee on Frequency Allocations for Radio Astronomy and Space Science):
Dr. H.S. Liszt (Chair, USA)

Prof. S. Ananthakrishnan (India, Comm J)
Dr. W.A. Baan (ex officio)
Prof. I. Häggström (USA, Comm G)
Prof. S. C. Reising (USA, Comm F)
Dr. A. T. Tzioumis (Australia, Comm J)
Dr. W. Van Driel (France, Comm J)

IUGG/IAGA (International Union of Geodesy and Geophysics/International Association of Geomagnetism and Aeronomy):
Prof. F. Lefevre (France)

SCAR (Scientific Committee on Antarctic Research):
Dr. G. de Franceschi (Italy)

SCOR (Scientific Committee on Oceanic Research):
Dr. R. Lang (USA)

SCOSTEP (Scientific Committee on Solar-Terrestrial Physics):
Prof. C. Rodger (New Zealand)

WHOEMF (World Health Organization – Electromagnetic Field Programme):
Prof. B. Veyret (France)

Editors of URSI Publications

Radio Science Bulletin

Editor-in-Chief : Prof. P. Lagasse

Editor : Dr. W. R. Stone

Production Editors: Ms Inge Lievens and Ms. Inge Heleu

Senior Associate Editors

Prof. O. Santolik

Dr. A. Pellinen-Wannberg

Associate Editor for YS Book Reviews

Dr. G. Trichopoulos

Associate Editor for Historical Papers

Prof. J. Mathews

Associate Editor for Telecommunications Health & Safety

Prof. J. C. Lin

Associate Editor for Solution Box

Dr. Ö. Ergül

Associate Editor for Et Cetera

Dr. T. Akgül

Associate Editor for Women in Radio Science

Dr. A. Pellinen-Wannberg

Associate Editor for the Historical Column

Dr. G. Pelosi

Associate Editor ECR Column

Dr. S. Wijnholds

Editorial Advisory Board

Prof. P. Cannon

Associate Editors:

Dr. P. Tavella, Dr. P. Duarte Cruz (Com. A)

Prof. K. Kobayashi, L. Li (Com. B)

S. El-Khamy, A.I. Zaghloul (Com. C)

Prof. G. Gradoni (Com. D)

Prof. F. Gronwald, Prof. G. Gradoni (Com. E)

Prof. V. Chandrasekar, Dr. M. Kurum (Com. F)

Dr. P. Doherty (Com. G)

Dr. J. Lichtenberger, W. Li (Com. H)

Dr. J. Baars (Com. J)

Prof. P. Mojabi (Com. K)

Records of URSI General Assemblies

Editor : Secretary General

Alphabetical Index and Co-ordinates

- A** BULDAHAB, Prof. M.A., Faculty of Engineering and Technology, Arab Academy for Science & Technology, P.O. Box 2033 Al-Horria, Heliopolis, Cairo, EGYPT, Tel. +2022 379273 95, Fax +2022 379273 95, E-mail mdahab@aast.edu (107)
- ADIMULA, Prof. I.A., Physics Department, University of Ilorin, Ilorin, NIGERIA, Tel. 234 802 629 2655, E-mail iaadimula@hotmail.com (112)
- AGUILERA, Mr. R., Centro de Estudios Espaciales, Universidad de Chile, Casilla 411-3, SANTIAGO 3, CHILE, Tel. +562-5568382, Fax +562-8441003 (107)
- AIKIO, Dr. A., Dept. of Physical Sciences, University of Oulu, PO Box 3000, FI-90014 OULU, FINLAND, Tel. +358 8 5531 363, Fax +358 8 5531 287, E-mail Anita.Aikio@oulu.fi (108)
- AJEWOLE, Prof. Oludare, Department of Physics, Federal University of Technology, Pmb 704, 340001 Akure, NIGERIA, Tel. 234 803 455 0871, E-mail oludare.ajewole@futa.edu.ng, oludareajewole61@yahoo.com (107)
- AKGÜL, Dr. T., Dept. of Electronics and Communications Engineering Telecommunications Division, Istanbul Technical University, 80626 Maslak Istanbul, TURKEY, Tel. +90 212 285 3605, Fax +90 212 285 3565, E-mail tayfun.akgul@ieee.org (113)
- AKSUN, Prof. I., College of Engineering, Koc University, Rumelifeneri Yolu, 34450 Sariyer Istanbul, TURKEY, Tel. +90 212 338 1539, Fax +90 212 338 1548, E-mail iaksun@ku.edu.tr (105)
- AL-BADRANI, Mr. M., Director, Directorate of International Cooperation, KACST, P.O Box 6086, RIYADH 11442, SAUDI ARABIA, Tel. +966 1 481 3384, Fax +966 1 481 3441, E-mail int_coop@kacst.edu.sa, mbadrani@kacst.edu.sa (112)
- AL-MIKATI, Prof. Dr. H.A., Faculty of Engineering, Mansoura University, Mansoura, Dakahlia, EGYPT, E-mail h.elmikati@gmail.com (109)
- AL-RAJEHI, Dr. A., Astronomy and Geophysics Research Institute, King Abdulaziz City for Science & Technology, P. O. Box 6086, RIYADH 11442, SAUDI ARABIA, Tel. +966 1 481 3535, Fax +966 1 481 3526, E-mail arrajehi@kacst.edu.sa (105, 107, 108, 109)
- ALENCAR, Prof. M.S. de, Centro de Ciências e Tecnologia, Departamento de Engenharia Eletrica, Universidade Federal de Campina Grande, Av. Aprigio Veloso 882, Bodocongo, 58109-970 Campina Grande, BP, BRASIL, Tel. + 55 83 3310 1122, E-mail malencar@ufcg.edu.br, malencar@iecom.org.br (106)
- ALENCAR, Prof. Luiz, Pontificia Universidade Catolica do Rio de Janeiro, Centro Técnico-Científico, Centro de Estudos em Telecomunicações, CETUC-PUC/Rio, Rua Marquês de S. Vicente 225, Gavea, 22453-900 Rio de Janeiro, BRAZIL, Tel. +55 21 31141618, E-mail semello@cetuc.puc-rio.br, lamello@inmetro.gov.br, larsmello@gmail.com (105)
- ALOMAINY, Dr. A., Engineering Building, Queen Mary, University of London, Mile End Road, London E1 4NS, UNITED KINGDOM, Tel. +44 020 7882 3324, E-mail a.alomainy@gmul.ac.uk (105)
- ALTINTAS, Prof. A., Dept. of Electr. & Electronics Eng., Bilkent University, Faculty of Engineering, 06533 Bilkent ANKARA, TURKEY, Tel. +90 312 290 1489, Fax +90 312 266 4192, E-mail altintas@ee.bilkent.edu.tr (112)
- ALVAREZ, Prof. H., Departamento de Astronomia, Universidad de Chile, Casilla 36-D, SANTIAGO 16, CHILE, Tel. +56 2-229 4002, Fax +56 2-229 4101, E-mail halvarez@das.uchile.cl (109)
- AMBROSINI, Dr. R., Institute of Radioastronomy, INAF, Via Gobetti 101, 40129 BOLOGNA, ITALY, E-mail r.ambrosini@ira.inaf.it (109)
- AMMANN, Dr. M., School of Electronic & Communications Engineering, Dublin Institute of Technology, Kevin Street, DUBLIN 8, IRELAND, Tel. +353 1 4024905, Fax +353 1 4024690, E-mail max.ammann@dit.ie (109)
- ANANTHAKRISHNAN, Prof. S., Electronic Science Department, Pune University, Ganeshkhind, PUNE 411007, INDIA, Tel. +91 20 2569 9841, Fax +91 20 6521 4552, E-mail subra.anan@gmail.com (104, 107, 113)
- ANDERSEN, Prof. J. Bach, Aalborg University, Inst. of Electronic Systems, Center for Personal Communication, Niels Jernes Vej 12, DK-9220 AALBORG EAST, DENMARK, Tel. +45 98314213, E-mail jba@es.aau.dk (109)
- ANDO, Prof. M., Dept. of Electrical & Electronic Eng., Graduate School of Science and Engineering, Tokyo Institute of Technology, S3-19, 2-12-1 O-okayama, Meguro, TOKYO 152-8552, JAPAN, Tel. +81 3 5734-2563, Fax +81 3 5734-2901, E-mail mando@antenna.ee.titech.ac.jp (104)
- ANGELSEN, Prof. B.A.J., Department of Circulation and Medical Imaging, NTNU, N-7487 TRONDHEIM, NORWAY, Tel. +47 91 320934, E-mail bjorn.angelsen@ntnu.no (109)
- ANTAR, Dr. Y.M.M., Electrical Engineering Department, Royal Military College, POB 17000, Station Forces, KINGSTON, ON K7K 7B4, CANADA, Tel. +1-613 541-6000 ext.6403, Fax +1-613 544-8107, E-mail antar-y@rmc.ca (104)
- ARES-PENA, Prof. F., Dpto. Fisica Aplicada, Facultad de Fisica, Universidad de Santiago de Compostela, 15782 Santiago de Compostela, SPAIN, Tel. +34 8818 140 16, Fax +34 8818 140 72, E-mail francisco.ares@usc.es (112)
- ARIKAN, Dr. F., Faculty of Engineering, Hacettepe University, Beytepe, Ankara, TURKEY, Tel. +312 297 7095, Fax +312 299 2125, E-mail arikan@hacettepe.edu.tr (108)
- ARMSTRONG, Dr. T.R., Measurement Standards Laboratory, Industrial Research Limited, P.O. Box 31-310, Lower Hutt, NEW ZEALAND, Tel. +64 4 931 3199, Fax +64 4 931 3194, E-mail t.armstrong@irl.cri.nz (105)

ARNAUT, Prof. L.R., Queen Mary University of London, Mile End Road, E14FZ London, UNITED KINGDOM, Tel. +44 20 78826125, E-mail luk.arnaut@googlemail.com, l.arnaut@qmul.ac.uk (110)

AROGUNJO, Prof. A.M., Department of Physics, Federal University of Technology, Akure, NIGERIA, Tel. 234 703 655 5992, E-mail arogmuyi@yahoo.com (109)

ARTHABER, Dr. H., Institute of Electrodynamics, Microwave and Circuit Engineering, Vienna University of Technology, Gusshausstrasse 25/354, 1040 Vienna, AUSTRIA, Tel. +43 1 58801 35 420, Fax +43 1 58801 935 420, E-mail holger.arthaber@tuwien.ac.at (105)

ASSIS, Prof. M.S., Rua Coelho Neto, 17 Ap.301, Laranjeiras, 22231-110 Rio de Janeiro, Brazil, Tel. +55 21 255 29487, E-mail msassis@openlink.com.br (107, 112)

AZI, Dr. S.O., University of Benin, Benin City, NIGERIA, Tel. 234 803 239 5000, E-mail saozil@yahoo.com (106)

BAAN, Prof. W.A., ASTRON, Asserweg 45, 9411 LP Beilen, NETHERLANDS, Tel. +31 521-595 773/100, Fax +31 521-595 101, E-mail baan@astron.nl (109, 110, 113)

BAARS, Dr. J.W.M., mm-astronomy, Max Planck Institute for Radio Astronomy, Auf dem Hügel 69, 53121 Bonn, Germany, Tel. +49-228-525303, E-mail jacobbaars@arcor.de (113)

BÄCKSTRÖM, Dr. M., Saab AB, SE-581 88 LINKÖPING, SWEDEN, Tel. +46 734 18 15 12, Fax +46 13 18 55 20, E-mail mats.backstrom@saabgroup.com (110)

BAE, Dr. S-H, Deputy Director (Principal Research Officer), 29 Wonhyoro 41 gil, Yongsangu, Seoul, 140-848, South Korea, Tel. +82 2 710 6527, Fax +82 2 710 6449, E-mail joseph@msip.go.kr (108)

BAGGALEY, Prof. W.J., Department of Physics and Astronomy, University of Canterbury, Private Bag, CHRISTCHURCH 1, NEW ZEALAND, Tel. +64 3-364-2558, Fax +64 3-364-2469, E-mail jack.baggaley@canterbury.ac.nz (108)

BAJAJA, Dr. E., Inst. Arg. de Radioastronomia, CC. No 5, 1894 VILLA ELISA, B.A., ARGENTINA, Tel. +54 221-4254909, Fax +54 221-4824903, E-mail bajaja@irma.iar.unlp.edu.ar (109)

BATISTA, Dr. I.S., INPE - Instituto Nacional de Pesquisas Espaciais, Av. dos Astronautas 1758, Jd. da Granja, 12227-010 Sao José dos Campos, SP, BRAZIL, Tel. +55 12 39456000 (108)

BEBBINGTON, Dr. D., School of Computer Science & Electronic Engineering, University of Essex, Wivenhoe Park, Colchester, CO4 3SQ, UNITED KINGDOM, Tel. +44 1206 872819, Fax +44 1206 872900, E-mail david@essex.ac.uk (107)

BENCZE, Prof. P., Geof. Kut. Labor, MTA (Hungarian Academy of Sciences), Csatkai E. u. 6, H-9400 SOPRON, HUNGARY, Tel. +36 99-314291, Fax +36 99-313267, E-mail bencze@ggki.hu (108)

BENTUM, Dr. Ir. M.J., Fac. of Electrical Eng. Mathematics & Computer Science, University of

Twente, Postbus 217, 7500 AE Enschede, Netherlands, Tel. +31 53 489 2108/3856, Fax +31 53 489 5640, E-mail m.j.bentum@utwente.nl (106, 112)

BETSKIY, Dr. O.V., FIRE, Russian Academy of Sciences, Vvedenskogo pl. 1, Fryasino, Moscow Region 141120, RUSSIA, Tel. +7 495 629 33 80, Fax +7 495 629 3678, E-mail ehf@cplire.ru (109)

BEUNZA, Eng. O.M., Cnel. Ramon L. Falcon 1535, 3rd floor, Apt. A, C1407GND BUENOS AIRES, ARGENTINA, Tel. +54 1-772-1471, Fax +54 11 4776 0410, E-mail postmast@caerce.edu.ar (107)

BHATTACHARYYA, Prof. A., Indian Institute of Geomagnetism, Plot-5; sector-18, Kalamboli Highway, New Panvel (W), Navi Mumbai, maharashtra 410218, India, Tel. +91 22 2748 4147, Fax +91 22 2748 0762, E-mail archana.bhattacharyya@gmail.com (104)

BILITZA, Dr. D., Space Weather Laboratory, George Mason University, 1856 Ingleside Terrace Nw, 20010 Washington, USA, Tel. +1 301 286-0190, Fax +1 301 286-1771, E-mail dieter.bilitza-1@nasa.gov, dbilitza@gmu.edu (111, 113)

BIOLEK, Prof. D., Brno University of Technology/ University of Defence Brno, Kounicova 65, BRNO 616 00, CZECH REPUBLIC, Tel. +420973442487, Fax +420 541 149 192, E-mail dalibor.biolek@unob.cz (106)

BITTENCOURT, Dr. J.A., INPE - Instituto Nacional de Pesquisas Espaciais, Av. dos Astronautas 1758, Jd. da Granja, 12227-010 Sao José dos Campos, S.P, BRAZIL, Tel. +55 12-39456000, Fax , E-mail jabittencourt@hotmail.com (108)

BOGENFELD, Dr. E., Deutsche Telekom AG, T-Labs (Research & Development), Wireless Technologies & Networks, Deutsche-Telekom-Allee 7, D-64295 DARMSTADT, GERMANY, Tel. +49 (0)6151 58 35834, Fax +49 (0)391 580216 938, E-mail eckard.bogenfeld@telekom.de (112)

BOLAS, Prof. T.E., LCDR, DITIC, Rua do Arsenal, 1149-001 LISBOA, PORTUGAL, Tel. +351 9177 44 784, Fax , E-mail ludovico.bolas@marinha.pt (108)

BORREGO, Eng. J.P., ICP-ANACOM, Centro de Monitorização e Controlo do Espectro do Sul, Alto do Paimão, 2730-216 BARCARENA, PORTUGAL, Tel. +351 21 434 85 00, Fax +351 21 434 85 90 E-mail jose.borrego@anacom.pt (107, 110)

BORTNIK, Dr. J., 201 Warwick Lane, Leonia, New Jersey, 07605, USA, Tel. (626) 354-0480, Fax (310) 206-5219, E-mail jbortnik@gmail.com (111)

BÖSCH, Prof. W., Institute of Microwave and Photonic Engineering, Graz University of Technology, Inffeldgasse 12, 8010 Graz, AUSTRIA, Tel. +43 316873 3301, Fax +43 316873 3302, E-mail wolfgang.boesch@tugraz.at (106)

BOSKA, Dr. J., Institute of Atmospheric Physics, Academy of Sciences of Czech Republic, Bocni II-1401, PRAGUE 4 141 31, CZECH REPUBLIC, Tel. +420 272 016 065, Fax +420 272 762 528, E-mail boska@ufa.cas.cz (108)

BRADLEY, Dr. R., Technology Center, National Radio Astronomy Observatory, 1180 Boxwood Estate Road, VA 22903 Charlottesville, United States, Tel. +1 434-296-0291, Fax +1 434-296-0324, E-mail rbradley@nrao.edu (109, 110)

- BRAZIL, Prof. T., UCDSchool of Electrical, Electronic and Mechanical Engineering, University College Dublin, DUBLIN, BELFIELD 4, IRELAND, Tel. +353 1 716 1929, Fax +353 1 283 0921, E-mail Tom.Brazil@ucd.ie (106)
- BREINBJERG, Prof. O., DTU Electrical Engineering, Technical University of Denmark, Oersteds Plads, Bldg. 348, DK-2800 LYNGBY, DENMARK, Tel. +45 4525 3814, Fax +45 4588 1634, E-mail ob@elektro.dtu.dk (105, 107, 112)
- BREKKE, Prof. A., Institute for Physics and Technology, University of Tromsø, N-9037 TROMSØ, NORWAY, Tel. +47 77 645 167, E-mail asgeir.brekke@uit.no (108)
- BRENNAN, Dr. C., School of Electronic Engineering, Dublin City University, DUBLIN 9, IRELAND, Tel. +353 1 7007649, E-mail BrennanC@eeng.dcu.ie (107)
- BROSCH, Dr. N., Wise Observatory, Tel Aviv University, Chayim Levanon St., Ramat Aviv, 69978 TEL AVIV, ISRAEL, Tel. +972 3 640-7413, Fax +972 3 640-8179, E-mail noah@wise.tau.ac.il (109)
- BRYNILDSEN, Ms. N., Institute of Theoretical Astrophysics, P.O. Box 1029 Blindern, N-0315 OSLO, NORWAY, Tel. +47 22 856502, Fax +47 22 856505, E-mail nilsbr@astro.uio.no (112)
- BULLETT, Dr. T., Cires, Noaa/ngdc, University of Colorado, 325 Broadway, E/GC2 Boulder Co, United States, Tel. 303-497-4788, E-mail Terry.Bullett@noaa.gov (110)
- BUZZI, Prof. S., DAEIMI, University of Cassino, Via G. di Biasio 43, 03043 Cassino, ITALY, E-mail buzzi@unicas.it (106)
- C**ALLEGARO, Dr. L., INRIM, Strada delle Cacce 91, 10135 Torino, ITALY, Tel. 011 391 94 35, E-mail l.callegaro@inrim.it (105)
- CALOZ, Dr. C., Pavillon Lassonde, M-6025, École Polytechnique, 2500, Chemin de Polytechnique, Montréal, Québec H3T 1J4, CANADA, Tel. +1 514 340 4711 ext. 3326, Fax +1 514 340 5892, E-mail christophe.caloz@polymtl.ca (106)
- CANNON, Prof. P.S., Gisbert Kapp Building, University of Birmingham, Edgbaston, Birmingham B15 2TT, UNITED KINGDOM, Tel. +44 (0) 7990 564772, Fax +44 (0) 121 414 4323, E-mail p.cannon@bham.ac.uk, president@ursi.org (104, 113)
- CAO, Dr., Space Science Institute, Beihang University, 37, Xueyuan Road, Haidian District, 100191 Beijing, China, Tel. 86.10.62582644, Fax 86.10.82338856, E-mail jbciao@buaa.edu.cn (108)
- CAPSALIS, Prof. C., Division of Information Transmission Systems and Material Technology, School of Electrical and Computer Engineering, National Technical University of Athens, Iroon Polytechniou 9, GR-15773 ATHENS, GREECE, Tel. +30 210 772 3517, Fax +30 210 772 2281, E-mail ccaps@central.ntua.gr (107)
- CAPSONI, Prof. C., Dept. Elettronica, Informazione e Bioingegneria (DEIB), Politecnico di Milano, Via Ponzia, 34/5, 20133 MILAN, ITALY, Tel. 02 23993572, E-mail capsoni@elet.polimi.it (107)
- CARLSSON, Dr. J., SP Technical Research Institute of Sweden, P.O. Box 857, SE-501 15 BORAS, SWEDEN, Tel. +46 10 516 51 69, Fax +46 33 12 19 30, E-mail jan.carlsson@sp.se (105)
- CARVALHO, Prof., Instituto de Telecomunicacoes, Universidade de Aveiro, Campus Universitario, 3810-193 Aveiro, PORTUGAL, Tel. +351 234377900, Fax +351 234377901, E-mail nbcarvalho@ua.pt (105)
- CERDEIRA, Dr. R.P., ESA-ESTEC, TEC-EEP, Postbus 299, 2200AG NOORDWIJK, NETHERLANDS, Tel. +31 71 565 8658, E-mail roberto.prieto.cerdeira@esa.int (108)
- CHAKRABARTI, Dr. N., Saha Institute of Nuclear Physics, 1/AF, Bidhannagar, Kolkata, 700064, INDIA, Tel. +91 33 23375345, Fax +91 33 23374637, E-mail nikhil.chakrabarti@saha.ac.in (108)
- CHANDRA, Prof. Dr. M., Chair-holder for Microwave Engineering and Photonics, Chemnitz University of Technology, Reichenhainer Strasse 70, D-09126 CHEMNITZ, GERMANY, Tel. +49 (0)371 531 33168, Fax +49 (0)371 531 8 33168, E-mail madhu.chandra@etit.tu-chemnitz.de (107, 110)
- CHANDRASEKAR, Prof. V., Engineering B117, Colorado State University, Fort Collins, Colorado 80523, USA, Tel. +1 970 491 7981, Fax +1 970 491 2249, E-mail chandra@engr.colostate.edu, chandra.ve@gmail.com (107, 113)
- CHANG, Prof. D-C, Oriental institute of Technology, 58, Sec.2, Sihchuan Rd., Pan-Chiao City, Taipei County 22061, TAIWAN, E-mail dcchang@mail.oit.edu.tw (105)
- CHANG, Prof. H-C, Department of Electrical Engineering, National Taiwan University, Room 513, Taipei 106-17, Taiwan, Tel. +886-2-23635251 ext., Fax +886 2 23637363, E-mail hungchun@ntu.edu.tw (105)
- CHAU, Dr. Jorge L., Jicamarca Radio Observatory, Instituto Geofisico del Peru, Apartado 13-0207, LIMA 13, PERU, Tel. +51 1-3172313, Fax +51 1-4344563, E-mail jchau@jro.igp.gob.pe, jorge.chau@jro.igp.gob.pe, chau2iap@gmail.com (108, 110)
- CHÁVEZ MUÑOZ, Ing. D., Departamento de Ingenieria, Universidad Católica del Perú, Grupo de Telecomunicaciones Rurales, Av. Universitaria 1801, San Miguel, LIMA 32, PERU, Tel. +51-1-626-2452, Fax +51-1-626-2116, E-mail dchavez@pucp.edu.pe (106, 112)
- CHEN, Prof. K-S, Center for Space and Remote Sensing Research, National Central University, No. 300, Jung-da Road, Jhongli City, TAOYUAN 320, CHINA (SRS), Tel. +886-3-4227151 ext 7617, Fax +886-3-4273586, E-mail dkschen@csrrs.ncu.edu.tw (107, 112)
- CHERPAK, Prof. N.T., A. Usikov Institute of Radiophysics and Electronics, NASU, 12, ac. Proskura Str., KHARKOV 61085, UKRAINE, Tel. +380 57 7203363, Fax +380 57 3152105, E-mail cherpak@ire.kharkov.ua (107)
- CHINEKE, Dr. T.C., Department of Physics and Industrial Physics, Imo State University, Owerri, Imo State, NIGERIA, Tel. 234 803 722 9905, E-mail chidiezie@yahoo.com (105)
- CHOL, Prof. J., Department of Electronics Convergence Engineering, Kwangwoon University, Wolgaedong, Npwon-gu, Seoul, 139-703, SOUTH KOREA, Tel. +82 2 940 5298, Fax +82 2 916 9270, E-mail jinchoi@kw.ac.kr (108)

- CHOUDHARY, Dr. R.K., Space Physics Laboratory, Vikram Sarabhai Space Center, Thumba, ISRO P.O., Trivandrum, Kerala 695 022, INDIA, Tel. +91 471 2562156, Fax +91 471 2706535, E-mail rajkumar_choudhary@vssc.gov.in, rajkumar.choudhary@gmail.com (107)
- CHRISOUOLIDIS, Prof. D.P., Division of Telecommunications, Dept. of Electrical and Computer Eng., Aristotle University of Thessaloniki, P.O. Box 1562, GR- 54124 THESSALONIKI, GREECE, Tel. +30 231 099 6334, Fax +30 231 099 6334, E-mail dpchris@eng.auth.gr (107)
- CHU, Prof. Y-H, Secretary General Office, National Central University, No. 300, Jungda Road, CHUNG-LI, TAOYUAN 320, CHINA (SRS), Tel. +886 3-4227151 ext. 57010, Fax +886 3-4254842, E-mail yhchu@jupiter.ss.ncu.edu.tw (108)
- CHUGUNOV, Prof. Yu.V., Institute of Applied Physics, Russian Academy of Sciences, Ul'yanova Street 46, NIZHNY NOVGOROD 603600, RUSSIA, Tel. +7 8314 384 232, Fax +7 8314 362 061, E-mail chugun@appl.sci-nnov.ru (108)
- CHUKHLANTSEV, Dr. A.A., Institute of Radio-engineering and Electronics, Russian Academy of Sciences, 1 Acad. Vvedensky Sq., Fryazino, Moscow Region, 141190 RUSSIA, E-mail chukhlantsev@ms.ire.rssi.ru (107)
- CHUKHRAY, Dr. G.I., Institute of Radioengineering and Electronics (IRE), Russian Academy of Science, Kirovogradskaya 18, MOSCOW 125009, RUSSIA, Tel. +7 495 311 6978, Fax +7 495 629 3678 (112)
- CHUKWUMA, Dr. V.U., Department of Physics, Olabisi Onabanjo University, P.O. Box 351, Ago Iwoye, NIGERIA, Tel. 234 805 507 5270, E-mail victorchukwuma@yahoo.com (105)
- CHUN, Prof. J., Department of Electrical Engineering, Korea Advanced Institute of Science & Technology, 291 Daehak-ro, Yusong-gu, Daejeon 305-701, SOUTH KOREA, Fax 042 350 8057, E-mail chun@kaist.ac.kr (106)
- CHUNG, Dr. S., National Radio Research Agency, 520-350 Naju-si, SOUTH KOREA, Tel. 82-61-338-4520, E-mail sychung@msip.go.kr (109)
- CLARK, Prof. A.R., School of Electrical and Information Eng., University of Witwatersrand, Room CM4-236, 3050 WITS, SOUTH AFRICA, Tel. +27 11 717 7223, Fax +27 11 403 1929, E-mail alanrobertclark@gmail.com (105)
- CLAUDE, Dr. S., National Research Council Canada, NRC Herzberg, 5071 West Saanich Road, VICTORIA, BC V9E 2E7, CANADA, Tel. +1 250 363 0030, Fax +1 250 363 0045, E-mail Stephane.Claude@nrc-cnrc.gc.ca (109)
- CLEMENTE, Dr. Pais, Director Serviço Otorrinolaringologia, Faculdade De Medicina Do Porto, Hospital De São João porto, Porto, Portugal, Tel. +351 21 721 2201, E-mail pais.clemente@mail.telepac.pt (109)
- CLÉNET, Dr. M., Defence Research and Development Canada-Ottawa, 3701 Carling Avenue, OTTAWA ON K1A 0Z4, CANADA, Tel. +1 613 998 7397, Fax +1 613 990 8906, E-mail Michel.Clenet@drdc-rddc.gc.ca (105)
- CLETTE, Dr. F., SIDC - Solar Physics, Royal Observatory of Belgium, 3, avenue Circulaire, B-1180 Bruxelles, Belgium, Tel. (322) 373-0233, Fax (322) 374-9822, E-mail frederic.clette@oma.be (109)
- CLILVERD, Dr. M.A., British Antarctic Survey, High Cross, Madingley Road, CAMBRIDGE, CB3 0ET, UNITED KINGDOM, Tel. +44 1223 221541, Fax +44 1223 221226, E-mail macl@bas.ac.uk (111)
- CLOSE, Dr. S., Dept. of Aeronautics and Astronautics, Stanford University, Stanford, CA 94306, United States, Tel. +1 650 725 2863, Fax +1 650 723 3738, E-mail sigridc@stanford.edu (108)
- COHEN, Prof. A., The Institute of Earth Science, The Hebrew University, Givat-Ram, P.O.B. 9137, 91091 JERUSALEM, ISRAEL, Tel. +972 2-658 6645, Fax +972 2-662 581, E-mail ariel@vms.huji.ac.il (107)
- COHEN, Dr. L., Radar Division, Naval Research Laboratory, Washington, DC 20375, USA, Tel. +1 202 404 7726, E-mail Lawrence.Cohen@nrl.navy.mil (107)
- COLLIER, Dr. , School of Physics, University of KwaZulu-Natal, Hospital Road, 4041 DURBAN, South Africa, Tel. +27 31 260 3158, Fax +27 31 261 6550, E-mail collierab@gmail.com (108)
- COSTA, Dr E., Centro Técnico-Científico, Centro de Estudos em Telecomunicações, Pontifícia Universidade Católica do Rio de Janeiro, CETUC-PUC/Rio, Rua Marquês de São Vicente 225, Gavea, 22453 - 900 Rio de Janeiro, Brazil, Tel. +55 21 311 41618, E-mail epoc@cetuc.puc-rio.br (105)
- CUPIDO, Prof. L., IPFN - Aveiro, Instituto de Telecomunicações-Polide Aveiro, Campus Universitario de Santiago, P- 3810-193 AVEIRO, PORTUGAL, Tel. +351 23 437 02 00, E-mail cupido@ua.pt (109)
- D**'INZEO, Prof. G., DIET, University of Rome "La Sapienza", Via Eudossiana, 18, I-00184 ROME, ITALY, Tel. +39 06 4458 5853, Fax +39 06 4742 647, E-mail dinzeo@die.uniroma1.it (109)
- DANILOV, Prof. V.V., Radiophysical Department, T. Shevchenko Kiev National University, 2 Glushkova avenue, Building 5, KIEV 03127, UKRAINE, Tel. +380 44 5260551, E-mail danilov@univ.kiev.ua (106)
- DATTA-BARUA, Dr. S., ASTRA, 12703 Spectrum Drive, San Antonio, TX, 78249, United States, Tel. (210) 877-9150, Fax (210) 877-9150, E-mail sdattabarua@gmail.com (108)
- DAVIS, Dr W.A., VA Tech, 302 Whittemore Hall - 0111, Blacksburg, VA 24061, USA, Tel. +1 540-231-6307, Fax +1 540-231-3362, E-mail wadavis@vt.edu (104)
- DE FRANCESCHI, Dr. G., Upper Atmosphere Physics, Istituto Nazionale di Geofisica e Vulcanologia, Via di Vigna Murata 605, 00 143 Roma, ITALY, Tel. +39 (06) 51860307, Fax +39 (06) 51860397, E-mail giorgiana.defranceschi@ingv.it (113)
- DE MOL, Prof. C., Campus Plaine CPI 217, Dept. Math. U.L.B., Boulevard du Triomphe, B-1050 BRUSSELS, BELGIUM, Tel. +32 2-650 55 73, Fax +32 2-650 51 13/58 67, E-mail demol@ulb.ac.be (112)

- DEBOER, Dr D.R., Radio Astronomy Laboratory, University of California Berkeley, 501 Campbell Hall, Berkeley, CA 94720 3411, USA, Tel. +1 510 520 9077, Fax +1 510 642 3411, E-mail ddeboer@berkeley.edu (109)
- DECHAMBRE, Dr. M., LATMOS, Quartier des garennes, 11 boulevard d'Alembert, F-78280 GUYANCOURT, FRANCE, Tel. + 33 1 80 28 50 80, E-mail monique.dechambre@latmos.ipsl.fr (107)
- DEHOLLAIN, Dr.C., EPFL, STI, IMM, LEG, ELB-Ecublens, Station 11, CH-1015 LAUSANNE, SWITZERLAND, Tel. +41 21 693 69 71, Fax +41 21 693 36 40, E-mail catherine.dehollain@epfl.ch (106)
- DEMIR, Assoc. Prof. S., Department of Electrical and Electronics Engineering, Faculty of Engineering, Middle East Technical University, Balgat, Ankara 06531, TURKEY, Tel. +90 312 210 2354, Fax +90 312 210 2304, E-mail simsek@metu.edu.tr (107)
- DENIAU, Mr. D., IFSTTAR, 20 rue elisée reclus, 59650 villeneuve d'ascq, FRANCE, Tel. 320438991, E-mail virginie.deniau@ifsttar.fr (107)
- DESCHAMPS, Mr., LERMA, Observatoire de Paris, 61 Avenue de l'Observatoire, F-75014 PARIS, FRANCE, Tel. +33 14051 5243, E-mail andre.deschamps@obspm.fr (109)
- DOHERTY, Prof. P., Co-Director/Research Scientist, Institute for Scientific Research, Boston College, 140 Commonwealth Avenue, CHESTNUT HILL, MA 02467, USA, Tel. +1 617 552 8767, Fax +1 617 552 2818, E-mail Patricia.Doherty@bc.edu (108, 110, 113)
- DOMINGUEZ, Eng. N.A., CORCA, Avenida del Libertador 327, 1638 VICENTE LOPEZ, B.A., ARGENTINA, Tel. +54 1-772-1471, Fax +54 11 4776 0410, E-mail postmast@caerce.edu.ar (112)
- DONG, Mr. Q-S, China Research Institute of Radio Wave Propagation, Beijing Research Center, PO Box 6301, 102206 BEIJING, CHINA (CIE), Tel. +86 37 3371 2001, E-mail qsdong22s@sina.com (107)
- DUARTE CRUZ, Dr. P.M., Instituto de Telecomunicações, Campus Universitário de Santiago, P-3810-193 AVEIRO, PORTUGAL, Tel. +351 234377900, E-mail pcruz@av.it.pt (105, 113)
- DUNLOP, Prof. M.W., Space Sciences Division, SSTD, Rutherford Appleton Laboratory, Chilton, Didcot, Oxfordshire, OX11 0QX, UNITED KINGDOM, Tel. +44 1235 44 5427, Fax +44 1235 44 5848, E-mail malcolm.dunlop@stfc.ac.uk (108)
- E**LHADIDI, Prof. Dr. M., Faculty of Engineering, Cairo University, Giza, EGYPT, E-mail hadidi@eun.eg (109)
- ELHENNAWY, Prof. H.M., Faculty of Engineering, Ain Shams University, 1 El-Sarayut Street, Abassio, Cairo, EGYPT, Tel. +202 2682 1800, Fax +202 26850617, E-mail helhennawy@ieee.org (105, 109)
- ELKHAMY, Prof. S.E., Dept. of Electrical Engineering, Alexandria University - Faculty of Engineering, Abou-Keer Street, ALEXANDRIA 21544, EGYPT, Tel. +2010-1497360, Fax +203 5971853, E-mail elkhamy@ieee.org, said.elkhamy@gmail.com (106, 112, 113)
- ERGUL, Assoc. Prof. O., Middle East Technical University, Department of Electrical and Electronics Eng., TURKEY, Tel. 905336353612, E-mail ozgur.ergul@eee.metu.edu.tr (113)
- F**AHMY, Prof. Dr. M., Faculty of Engineering, Assiut University, 71515 Assiut, EGYPT, E-mail mamdouhffahmy@gmail.com (105)
- FALODUN, Dr. S.E., Department of Physics, Federal University of Technology, AKURE, NIGERIA, Tel. 234 803 353 4973, E-mail bestal@yahoo.com (106)
- FARKAS, Prof. P., Fac. of Electrical Eng. & Information Technology, Slovak University of Technology, Ilkovicova 3, BRATISLAVA 812 19, SLOVAKIA, Tel. +421-2-60 29 18 44, Fax +421-2-68 27 96 01, E-mail p.farkas@ieee.org (106)
- FEICK, Dr. R., Depto. de Electronica, Universidad Técnica Federico Santa María, Casillo 110 V, VALPARAISO, CHILE, Tel. +56 32-626 364 ext. 209, Fax +56 32-665 010, E-mail rodolfo.feick@usm.cl (106)
- FEJES, Prof. I., Moricz zs. u. 16/A, SOLYMAR 2083, HUNGARY, Tel. +36 27 374 980, Fax +36 27 374 982, E-mail fejes@gpsnet.hu (109)
- FERDINANDOV, Prof. E., Technical University of Sofia, 8, Kliment Ohridski Str., 1756 SOFIA, BULGARIA, Tel. +359 2 965 3275, E-mail ef_lor@ie.bas.bg (105)
- FERENCZ, Prof. Cs., ELTE Department of Geophysics, Space Research Group, Pazmany Peter setany 1/A, H-1117 BUDAPEST, HUNGARY, Tel. +36 1 209 0555/6652, Fax +36 1 372 2927, E-mail spacerg@sas.elte.hu, csaba@sas.elte.hu (108)
- FICHTE, Dr. Ing. L.O., Theoretische Elektrotechnik, Helmut-Schmidt-Universität, Holstenhofweg 85, 22043 Hamburg, GERMANY, Tel. +49 40 6541 2460, Fax +49 40 6541 2282, E-mail lars-ole.fichte@hsu.hh.de, fichte@ieee.org (109)
- FISER, Assoc. Prof. O., Institute of Atmospheric Physics, Academy of Sciences of the Czech Republic, Bocni II - 1401, PRAGUE 4 141 31, CZECH REPUBLIC, Tel. +420 272 016 038, Fax +420 272 763 745, E-mail Ondrej@ufa.cas.cz (112)
- FLOURY, Prof. N., Head, Wave Interaction & Propagation Section, ESA-ESTEC, TEC-EEP, Keplerlaan 1, PO Box 299, NL-2200 AG Noordwijk, The Netherlands, Tel. +31 71 565 3581, Fax +31 71 565 4999, E-mail Nicolas.Floury@esa.int (110)
- FOERSTER, Dr. M., Helmholtz Centre Potsdam, GFZ German Research Centre for Geosciences, Telegrafenberg, D-14473 Potsdam, Germany, Tel. +49 (0) 331 288 1776, Fax +49 (0) 331 288 1235, E-mail mfo@gfz-potsdam.de (108)
- FOPPIANO, Dr. A., Departamento de Geofísica, Universidad de Concepción, Casilla 160-C, Correo 3, CONCEPCION, CHILE, Tel. +5641-312413, Fax +5641-312863, E-mail alberto.foppiano@dgeo.udec.cl (108)

- FORSSELL, Prof. B., Department of Electronics and Telecommunications, NTNU O.S., Bragstads plass 2, N-7491 TRONDHEIM, NORWAY, E-mail borje.forssell@iet.ntnu.no (106)
- FRANCHOIS, Prof. A.I., Information Technology (INTEC), Ghent University, Sint Pietersnieuwstraat 41, B-9000 GHENT, BELGIUM, Tel. +3292648937, Fax +3292649969, E-mail Ann.Franchois@intec.ugent.be (109)
- FROLLO, Prof. I., Institute of Measurement Science, Slovak Academy of Sciences, Dubravska Cesta 9, BRATISLAVA 841 04, SLOVAKIA, Tel. +421 2-591 04 422, Fax +421 2-5477 5943, E-mail frollo@savba.sk (109)
- FRØYSTEIN, Dr. H.A., Justervesenet, Festveien 99, N-2007 Kjeller, NORWAY, Tel. +47 64 848484, Fax +47 64 848485, E-mail haf@justervesenet.no (105)
- FUJISAWA, Dr. K., Yamaguchi University, Yoshida 1677-1, Yamaguchi-city, Yamaguchi 753-8511, Japan, Tel. +81-83-933-5973, Fax +81-83-933-5973, E-mail kenta@yamaguchi-u.ac.jp (109)
- FULLEKRUG, Dr. M., Dept. of Electronic and Electrical Engineering, University of Bath, 2 East 3.8, Claverton Down, Bath, BA2 7AY, UNITED KINGDOM, Tel. +44 1225 386053, Fax +44 1225 386305, E-mail eesmf@bath.ac.uk (107)
- FUSCO, Prof. V.F., ECIT Institute, The Queen's University of Belfast, Northern Ireland Science Park, Queens Road, Queen's Island, BELFAST BT3 9DT, NORTHERN IRELAND, Tel. +44 28 9097 1700, Fax +44 28 9097 1702, E-mail michelle.mccusker@ecit.qub.ac.uk (105)
- G**AGLIARDINI, Dr. D.A., Julian Alvarez 1218, 1414 BUENOS AIRES, ARGENTINA, Tel. +54 1-772-1471, Fax +54 11 4776 0410, E-mail postmast@caerce.edu.ar (107)
- GALKIN, Mr. I., University of Massachusetts Lowell, 600 Suffolk Str, 01862 Lowell, MA, UNITED STATES, Tel. 978-934-4912, E-mail Ivan.Galkin@borealis-designs.com, ivan_galkin@uml.edu (110)
- GALLEGO PUJOL, Dr. J.D., Observatorio Astronomico Nacional, Apdo 1143, Alcala de Henares, 28800 MADRID, SPAIN, Tel. +34 91 885 5060, Fax +34 91 885 5062, E-mail gallego@oan.es (107)
- GALOPEAU, Prof. P., LATMOS, Quartier des Garennes, 11 boulevard d'Alembert, F-78280 GUYANCOURT, FRANCE, Tel. +33 1 80 28 50 67, E-mail patrick.galopeau@latmos.ipsl.fr (108)
- GARAVAGLIA, Prof. M., Departamento De Física, Centro De Investigaciones Opticas, Camino Centenario Y 506, Gonnet, CC31897 La Plata, Argentina, Tel. ++ 54 221 471 4341, Fax ++ 54 221 471 4341, E-mail garavagliam@ciop.unlp.edu.ar (106)
- GARBINI, Ing. A., CORCA, Avenida del Libertador 327, 1638 VICENTE LOPEZ, B.A., ARGENTINA, Tel. +54 11 4772 1471, Fax +54 11 4776 0410, E-mail postmast@caerce.edu.ar (112)
- GARDNER, Dr. R.L., 6152 Manchester Park Circle, ALEXANDRIA, VA 22310-4957, USA, Tel. +1 703-924-9370, Fax +1 703-313-4179, E-mail Robert.L.Gardner@verizon.net (110)
- GAVAN, Prof. J., Sami Shamoon College of Engineering, Jabutinsky 84, ASHDOD, ISRAEL, E-mail jacobg@sce.ac.il (110)
- GEORGIADIS, Dr. A., Department of Microwave Systems and Nanotechnology, Centre Tecnologic de Telecomunicacions de Catalunya (CTTC), PMT BUILDING B4, Avda Carl Friedrich Gauss 7, Castelldefels 08860, SPAIN, Tel. +34 93 6452900, E-mail apostolos.georgiadis@cttc.es (106)
- GEZICI, Dr. S., Faculty of Engineering, Bilkent, Ankara 06800, TURKEY, Tel. +312 290 3139, Fax +312 266 4192, E-mail gezici@ee.bilkent.edu.tr (107)
- GIMM, Prof. Y.M., School of Electronics and Electrical Engineering, Dankook University, Jukjeon-dong 126, Suji-gu, YONGIN-SI 448-701, SOUTH KOREA, Tel. +82 2 793 8732, Fax +82 2 793 1150, E-mail gimm@dku.edu (109)
- GIRALDEZ, Prof. A., LIARA, avda. del Libertador 327, 1638 VICENTE LOPEZ, B.A., ARGENTINA, Tel. +54 1-791-5001, Fax +54 1-776-0410 (108)
- GIRI, Adj. Prof. D.V., Dept of ECE, University of new Mexico, Pro-Tech, 11-C Orchard Court, ALAMO, CA 94507 1541, USA, Tel. +1 925 552 0510, Fax +1 925 552 0532, E-mail Giri@DVGiri.com (107)
- GLOVER, Prof. Andrew, Department of Engineering & Technology, University of Huddersfield, Queensgate, Huddersfield HD1 3DH, United Kingdom, Tel. +44 1484 473 133, Fax +44 1484 421 106, E-mail i.a.glover@hud.ac.uk (112)
- GOETZE, Prof. Dr. J., Arbeitsgebiet Datentechnik, Technische Universitaet Dortmund, Fakultat ET/IT, Otto-Hahn Strasse 4, D-44227 Dortmund, GERMANY, Tel. +49 (0)231 755 2091, Fax +49 (0)231 755 7019, E-mail juergen.goetze@uni-dortmund.de (106)
- GOMBEROFF, Prof. L., Depto de Física - Facultad de Ciencias, Universidad de Chile, Casilla 653, SANTIAGO, CHILE, Tel. +56 2-271 2865, Fax +56 2-271 3882, E-mail lgombero@abello.dic.uchile.cl (108)
- GOUGH, Dr. P.T., Dept. of Electrical and Computer Engineering, University of Canterbury, Private Bag 4800, CHRISTCHURCH 1, NEW ZEALAND, Tel. +64 3 364-2297, Fax +64 3 364-2761, E-mail peter.gough@canterbury.ac.nz (106)
- GRADONI, Dr. G., School of Mathematical Sciences, University of Nottingham, University Park, Nottingham NG7 2RD, UNITED KINGDOM, Tel. +44(0)7745368300, Fax +44(0)1159514951, E-mail gabriele.gradoni@gmail.com, gabriele.gradoni@nottingham.ac.uk (107, 113)
- GRAHAM, Ms. Y., Programme Manager, Royal Irish Academy, 19 Dawson Street, Dublin D02 HH58, IRELAND, Tel. +353 1 6762570, E-mail Y.Graham@ria.ie (112)
- GRAINGE, Mr. K., University of Manchester, 26 Carrwood Road, SK9 5DL Wilmslow, UNITED KINGDOM, Tel. 447920575647, E-mail keith.grainge@manchester.ac.uk (109)

- GRANUCCI, Dr. G., Istituto di Fisica del Plasma ‘Piero Caldirola’, Consiglio Nazionale delle Ricerche, Via Roberto Cozzi, 53, 20125 Milano, ITALY, Tel. 02 661 73 266, E-mail granucci@ifp.cnr.it (108)
- GRAY, Dr. A.D., National Research Council Canada, NRC Herzberg, P.O. Box 248, PENTICTON, BC V2A 6J9, CANADA, Tel. +1 250 497 2313, Fax +1 250 497 2355, E-mail Andrew.Gray@nrc-cnrc.gc.ca (112)
- GRONWALD, Professor F., Hamburg University Of Technology, Electromagnetic Theory, Harburger Schloss Str. 20, 21079 Hamburg, Germany, Tel. +49-40-42878-2177, E-mail gronwald@tuhh.de (107, 110, 113)
- GUEVARA DAY, Dr. W.R., National Commission on Aerospace Research and Development (CONIDA), Felipe Villaran 1069, San Isidro, LIMA 27, PERU, Tel. +51 1-4429973, Fax +51 1-4419081, E-mail walter@conida.gob.pe (108)
- GUHA, Dr. D., Electronics & Electrical Communication Engineering, Indian Institute of Technology Kharagpur, West Bengal, 721302, India, Tel. (+91) 3222 283522, Fax (+91) 92313 53055/8697571084, E-mail dguha@ieee.org (105)
- GULYAEV, Prof. S., Auckland University of Technology, Institute For Radio Astronomy And Space Research, Private Bag 92006, 1142 Auckland, NEW ZEALAND, Tel. +64 9 921 9999 ext 8709, 9541, Fax +64 9 921 9973, E-mail sergei.gulyaev@aut.ac.nz (109)
- GULYAEV, Dr. Yu. V., Institute of Radioengineering and Electronics, Russian Academy of Sciences (IRE RAS), Mokhovoja Street 11, MOSCOW 125009, RUSSIA, Tel. +7 495 629 3591, Fax +7 495 629 3678, E-mail gulyaev@cplire.ru (112)
- GUO, Dr. H., Director, Center for Quantum Information Technology, Peking University, Beijing, 100871, CHINA (CIE), Tel. +86 10 6275 7035, Fax +86 6275-7035-3208, E-mail hongguo@pku.edu.cn (106)
- GUTIERREZDELACRUZ, Dr. C.M., Instituto de Astrofísica de Canarias, C/ Via Lactea, s/n, 38205 LA LAGUNA, TENERIFE, SPAIN, E-mail cgc@iac.es (109)
- HABARULEMA, Dr. J.B., Space Science Directorate, South African National Space Agency, P.o Box 32 Hermanus, 7200 Hermanus, South Africa, Tel. +27283121196, Fax +27283122039, E-mail jhabarulema@sansa.org.za (110)
- HÄGGSTRÖM, Prof. I., EISCAT Scientific Association, Box 812, S-981 28 KIRUNA, SWEDEN, Tel. +46 9807 87 01, Fax +46 9807 87 09, E-mail ingemar.haggstrom@eiscat.se (108, 113)
- HALEVY-POLITCH, Dr. J., P.O. Box 7205, 31071 HAIFA, ISRAEL, Tel. +972 4-879 4862, Fax +972 4-879 4875, E-mail aeryapo@techunix.technion.ac.il (105)
- HALLIKAINEN, Prof. M.T., Dept. of Radio Science and Engineering, Aalto University, P.O. Box 13000, FI-00076 AALTO, FINLAND, Tel. +358 9 470 22371, E-mail Martti.Hallikainen@aalto.fi (107)
- HAMELIN, Mr. J., Conseiller Scientifique, Centre d’analyse stratégique (CAS), 18, rue de Martignac, F-75700 Paris Cedex 07, FRANCE, Tel. +33 1 42 75 60 35, E-mail ursi-france@institut-telecom.fr (104)
- HAMNERIUS, Prof. Y., Signals and Systems, Chalmers University of Technology, 412 96 GÖTEBORG, SWEDEN, Tel. +46 31 772 19 05, Fax +46 31 772 17 48, E-mail yngve.hamnerius@chalmers.se (109)
- HAN, Dr. S-T, Korea Astronomy & Space Science Institute, 667 Daeduckdae-ro, Yuseong-gu, DAEJEON 305-340, SOUTH KOREA, Tel. +82 42 865 3283, Fax +82 42 865 5610, E-mail sthan@kasi.re.kr (109)
- HARTAL, Mr. O., RAFAEL, P.O. Box 2250, 31021 HAIFA, ISRAEL, Tel. +9724-8792931, Fax +9724-8795329 (107)
- HASHIMOTO, Dr. K., Director, Paleological Association of Japan, Inc., 48 Hishiya-cho, Sanjo and Takakura, Nakagyo, 604-813 Kyoto, Japan, Tel. +81-252-3000, Fax +81-252-3001, E-mail kozo@rish.kyoto-u.ac.jp (110)
- HATTORI, Dr. K., Department of Earth Sciences, Faculty of Science, Chiba University, Yaoi, 1-33, Inage, CHIBA 263-8522, JAPAN, Tel. +81 43 290 28 01, Fax +81 43 290 28 59, E-mail hattori@earth.s.chiba-u.ac.jp (110)
- HE, Prof. R., Room 0512, XueYuan 3 Building, Beijing Jiaotong University, No. 18 JiaoDa East Road, Beijing 100044, CHINA, E-mail ruisi.he@ieee.org (106)
- HELEU, Mrs. I., URSI Secretariaat, URSI, c/o INTEC, Sint-Pietersnieuwstraat 41, B-9000 GHENT, BELGIUM, Tel. +32 9-264.33.20, Fax +32 9-264.42.88, E-mail info@ursi.org (104)
- HERAUD, Dr. J., Instituto de Radioastronomia INRAS-PUCP, Pontificia Universidad Catolica del Peru, Av. Universitaria 1801, San Miguel, LIMA 32, PERU, Tel. +51 1 6262000 (ext. 4735), E-mail jheraud@pucp.edu.pe (109, 112)
- HEYMAN, Prof. E., The Iby and Aladar Fleischman Faculty of Engineering, Tel Aviv University, 69978 TEL AVIV, ISRAEL, Tel. +972 3 6408738/8736/8147, Fax +972 3 6407221, E-mail heyman@tau.ac.il (112)
- HJELMSTAD, Dr. J.Fr., Department of Electronics and Telecommunications, NTNU, O.S. Bragstads plass 2, 7491 TRONDHEIM, NORWAY, Tel. +47 45 249613, E-mail jens@hjelmsstad.no (107)
- HO, Prof. T.P., Academia Sinica, Institute of Astronomy and Astrophysics, P.O. Box 23-141, TAPEI 106, TAIWAN, Tel. +886 2 33652200 x700, Fax +886 2 23677849, E-mail pho@asiaa.sinica.edu.tw (109)
- HOBARA, Prof. , Dept. Of Communication Eng. And Informatics, The University Of Electro-communications, 1-5-1, Chofugaoka, 182-858 Chofu, Japan, Tel. +81-424435154, E-mail hobara@ee.uec.ac.jp (110)
- HONARY, Prof F., Physics Department, Lancaster University, Lancaster, LA1 4YB, UNITED KINGDOM, Tel. +44 152 4510 402, Fax +44 152 4844 037, E-mail f.honary@lancaster.ac.uk (108)
- HOUMINER, Dr. Z., Asher Space Research Institute, Technion, Israel Institute of Technology, 32000 HAIFA, ISRAEL, Tel. +972 4-829 3512, Fax +972 4-823 0956, E-mail zwih@tx.technion.ac.il (108)

HØEG, Prof. P., DTU Space, Technical University of Denmark, National Space Institute, Department for Geodesy, Juliane Maries Vej 30, 2100 Copenhagen, DENMARK, Tel. +45 3532 5702, E-mail hoeg@space.dtu.dk , per.hoeg@gmail.com (108)

HUBBARD, Mr. R., EMC/EMF, Eskom Resources & Strategy, Johannesburg, SOUTH AFRICA, Tel. +27 11 629 5236, E-mail roy.hubbard@eskom.co.za (109)

HUFF, Dr. G.H., Dept. of Electrical & Computer Engineering, Texas A&M University, 3128 TAMU, College Station, TX 77843-3128, United States, Tel. +1 979 862 4161 , Fax +1 979 845-6259, E-mail ghuff@tamu.edu (106)

ILMONIEMI, Prof. R., Dept. Biomedical Eng. and Computational Science, Aalto University, P.O. Box 12200, FI-00076 AALTO, Finland, Tel. +358 50 5562964, Fax +358 947023182, E-mail risto.ilmoniemmi@aalto.fi (109)

INAN, Prof. U.S., Director, STAR Laboratory, Electrical Eng. Dept, Stanford University, Packard Bldg. Rm. 355, 350 Serra Mall, Stanford, CA 94305, USA, Tel. +1-650 723-4994, Fax +1-650 723-9251, E-mail inan@stanford.edu, uinan@ku.edu.tr (104)

INAN, Prof. U.S., REKTOR, Koç Üniversitesi, Rumelifeneri Yolu, 34450 SARIYER, TURKEY, Tel. +90 212 338 1213, Fax +90 212 338 1248, E-mail uinan@ku.edu.tr (104)

ISNARD, Dr. J.J., CNFRS, 28, avenue de Breteuil, F-75007 PARIS, FRANCE, Tel. +33 1-45 66 55 99, Fax +33 1 45 66 55 99, E-mail jisnard-isti@club-internet.fr (110)

ITO, Prof. K., Center for Frontier Medical Engineering, Chiba University, 1-33 Yayoi-cho, Inage-ku, Chiba-shi 263-8522, Japan, Tel. +81-43-290-3326, Fax +81-43-290-3327, E-mail ito.koichi@faculty.chiba-u.jp (109)

JACARD, Prof. B., Depto. de Ingenieria Electronica, Universidad de Chile, Casilla 412-3, SANTIAGO 3, CHILE, Tel. +56 2-698 2071 ext. 204, Fax +56 2-695 3881, E-mail benjamin.jacard@umayor.cl (105, 112)

JACKSON, Prof. R., Electrical And Computer Engineering, University Of Houston, n308 Engineering Building 1, TX 77204-4005 Houston, USA, Tel. +1 713-743-4426, Fax +1 713-743-4444, E-mail djackson@uh.edu (112)

JANARDHAN, Prof. P., Physical Research Laboratory, Ahmedabad 380009, INDIA, Tel. +91 79 2631 4505, E-mail jerry@prl.res.in (109)

JAYACHANDRAN, Mr. P.T., Department of Physics, University of New Brunswick, 8 Bailey Drive, P.O. Box 4440, Fredericton, NB E3B 5A3, CANADA, Tel. +1 506 4473330, Fax +1 506 4534583, E-mail jaya@unb.ca (108)

JIRICKA, Dr. K., Astronomical Institute, Academy of Sciences of the Czech Republic, Fricova 1, Ondrejov 251 65, CZECH REPUBLIC, Tel. +420 323 620 154, Fax +420 323 620 110, E-mail jiricka@asu.cas.cz (109)

JOHANSSON, Dr. J.F., RUAG Space AB, SE-405 15 GÖTEBORG, SWEDEN, Tel. +46 31 735 4286, Fax +46 31 735 4000, E-mail joakim.johansson@ruag.com (107)

JOHNSON, Dr. N., Optoelectronics Group, Electronics and Nanoscale Eng., Rankine Building, Glasgow G12 8LT, Tel. +44 014 1330 4110, E-mail Nigel.Johnson@glasgow.ac.uk (106)

JONAS, Prof. J., Department of Physics and Electronics, Rhodes University, PO Box 94, 6140 GRAHAMSTOWN, SOUTH AFRICA, Tel. +27 46 603 8452, Fax +27 46 622 5049, E-mail j.jonas@ru.ac.za (104, 109)

KALINOWSKI, Prof. H.J., Depog - Departamento de Pos Graduação e Pesquisa, Universidade Tecnológica Federal do Paraná, Av. Sete de Setembro 3165, Rebouças, 80230-901 CURITIBA, PR, BRAZIL, Tel. +55 41 33104689, Fax +55 41 33104683, E-mail hjkalin@gmail.com (106)

KALOUPSIDIS, Prof. N., Division of Communications and Signal Processing, Dept. of Informatics, University of Athens, TYPA Buildings, Panepistimiopolis, GR-15771 ILISSIA, ATHENS, GREECE, Tel. +30 210 727 5304, Fax +30 210 727 5601, E-mail kalou@di.uoa.gr (106)

KANELLOPOULOS, Prof. J., Division of Information Transmission Systems and Material Technology, School of Electr. & Computer Eng., National Technical University of Athens, Iroon Polytechniou 9, GR-15773 ATHENS, GREECE, Tel. +30 210 772 3524, Fax +30 210 772 2281, E-mail ikanell@cc.ece.ntua.gr (108)

KASAHARA, Prof. Y., Information Media Center, Kanazawa University, Kakuma-machi, KANAZAWA 920-1192, JAPAN, Tel. +81 762344952, Fax +81 76234 4952, E-mail kasahara@is.t.kanazawa-u.ac.jp (108)

KASTNER, Prof. R., Dept. Electrical Eng.-Physical Electronics, Tel Aviv University , 243 Wolfson Electrical Eng Bldg, 62978 TEL AVIV, ISRAEL, Tel. +972 3-640 7447, Fax +972 3-642 3508, E-mail kast@eng.tau.ac.il (105, 112)

KATAMZI, Ms. Z., Space Science, South African National Space Agency (SANSA), PO Box 32, Hermanus 7200, UNITED KINGDOM, Tel. +27 (0)28 312 1196, Fax +27 (0)28 312 2039, E-mail zkatamzi@sansa.org.za (108)

KATULSKI, Prof. R., Department Of Radiocommunication Systems And Networks, Gdansk University Of Technology, Narutowicza Street 11/12, 80-233 Gdansk, Poland, Tel. +48 58 347 21 08, Fax +48 58 347 25 62, E-mail rjkat@eti.pg.gda.pl (105)

KAUFMANN, Prof. P., CRAAM/CRAAE (Mackenzie, Inpe, USP, Unicamp), Universidade Presbiteriano Mackenzie, Rua da Consolacao 896, 1321907 Sao Paulo, BRAZIL, Tel. +55 11 236 8331, Fax +55 11 214 2300, E-mail kaufmann@craam.mackenzie.br, pierrekauf@gmail.com (104, 109)

KENDERESSY, Prof. M., Ribary u. 7, H-1022 Budapest, HUNGARY, Tel. +36 1-461-3348 (105)

KEYDEL, Prof. Dr. W., Mittelfeld 4, 82229 Hechendorf, GERMANY, Tel. +49 (0)8152-980 523, Fax +49 (0)8152-980 525, E-mail wolfgang@keydel.com (110)

KHALIL, Dr. D.A., Faculty of Engineering, Ain Shams University, 1 Elsarayat St. - Abbasia, CAIRO, EGYPT, E-mail Daa.khalil@ieee.org (106)

- KIKUMA, Prof. N., Department of Computer Science and Engineering, Graduate School of Engineering, Nagoya Institute of Technology, Gokiso-cho, Showa-ku, Nagoya, Aichi, 466-8555, JAPAN, Tel. +81 52 735 5443, Fax +81 52 735 5443, E-mail kikuma@nitech.ac (106)
- KILIFARSKA, Dr. N., National Institute of Geophysics, Geodesy and Geography (NIGGG), Bulgarian Academy of Sciences, Acad. G. Bonchev St., bl. 3, 1113 SOFIA, BULGARIA, Tel. +359 2 979 3329, E-mail nkilifarska@geophys.bas.bg (108)
- KILLAT, Prof. Dr. D., Lehrstuhl Mikroelektronik, Brandenburgische Technische Universität Cottbus, Konrad-Wachsmann-Allee 1, D-03046 Cottbus, GERMANY, Tel. +49 (0) 355 692811, Fax +49 (0) 355 69 28 12, E-mail killat@tu-cottbus.de (106)
- KIM, Dr. J.H., Electromagnetic Wave Center, Korea Research Institute of Standards & Science, 267 Gajeong-ro, Yuseong-gu, DAEJEON 305-340, SOUTH KOREA, Tel. +82 42 868 5170, Fax +82 42 868 5018, E-mail kimjh@kriss.re.kr (105)
- KNEPPO, Prof. I., Faculty of Special Technology, Alexander Dubcek University of Trencin, Pri parku 19, TRENCIN 911 06, SLOVAKIA, Tel. +421 32 7400 275, E-mail ivan.knepo@gmail.com (105)
- KNUDE, Dr. J., Astronomical Observatory, University of Copenhagen, Juliane Maries Vej 30, DK 2100 Copenhagen, DENMARK, Tel. +45 3532 5986, Fax +45 3532 5989, E-mail indus@astro.ku.dk (109)
- KOBAYASHI, Prof. K., Department of Electrical, and Communication Engineering, Chuo University, 1-13-27 Kasuga, Bunkyo-ku, TOKYO, 112-8551, JAPAN, Tel. +81 3 3817 1846/69, Fax +81 3 3817 1847, E-mail kazuya@tamacc.chuo-u.ac.jp (104, 105, 112, 113)
- KÖKSAL, Dr. Adnan, Electrical And Electronics Engineering, Hacettepe University, 06800 Ankara, Türkiye, Tel. 3122977085, Fax 3122992125, E-mail koks@hacettepe.edu.tr (109)
- KONOVALENKO, Prof. A.A., Institute of Radioastronomy, NASU, ul. Krasnoznamenaya 4, Kharkov 61002, UKRAINE, Tel. +380 572-47-1134, Fax +380 572-47-6506, E-mail rian@rian.kharkov.ua (109)
- KORENSTEIN, Prof. R., Physiology And Pharmacology, Tel-Aviv University, Haim Levanon 5000, 69978 TEL AVIV, ISRAEL, Tel. +972 3640 6042, Fax +972 3640 9113, E-mail korens@post.tau.ac.il (109)
- KOSCH, Prof. M.J., Communication Systems, Lancaster University, Alexandra Square, LANCASTER, LA1 4YR, UNITED KINGDOM, Tel. +44-1524-510404, E-mail m.kosch@lancaster.ac.uk (110)
- KOUDELKA, Prof. O., Institute of Communication Networks and Satellite Communications, Graz University of Technology, Inffeldgasse 12, 8010 Graz, AUSTRIA, Tel. +43 316 873 7440, Fax +43 316 873 7941, E-mail koudelka@tugraz.at (106)
- KOYAMA, Prof. Y., Space-Time Standards Group, New Generation Network Research Center, National Institute of Information and Communication Technology (NICT), 4-2-1, Nukui-kitamachi, Koganei, TOKYO 184-8795, JAPAN, Tel. +81 42 327 7557, Fax +81 42 327 6834, E-mail koyama@nict.go.jp (105)
- KRAJCUSKOVA, Dr. Z., Fac. of Electrical Eng.&Information Technology, Slovak University of Technology, Ilkovicova 3, BRATISLAVA 812 19, SLOVAKIA, Tel. +421-2-6029 1137, Fax +421-2-6542 9683, E-mail zuzana.krajcuskova@stuba.sk (112)
- KRAUS, Dr. A., Max-Planck-Institut fuer Radioastronomie, Radioobservatorium Effelsberg, Max-Planck-strasse 28, D-53902 Bad Muenstereifel-Effelsberg, GERMANY, Tel. +49 (0)2257 301 120, Fax +49 (0)2257 301 105, E-mail akraus@mpifr.de (109)
- KRAWCZYK, Prof. A., Military Institute of Hygiene & Epidemiology, 29 Lokalna Street, 04-903, POLAND, Tel. +48 22 8724 282, E-mail ankra.new@gmail.com (109)
- KRIEZIS, Prof. E., Dept. of Electrical and Computer Engineering, Aristotle University of Thessaloniki, GR- 54124 THESSALONIKI, GREECE, Tel. +30 2310 995920, Fax +30 2310 996312, E-mail mkriezis@auth.gr (106)
- KUCHARSKI, Prof. A., Faculty of Electronics, Wrocław University of Technology, 27 Wybrzeze, Wyspianskiego Street, 50-370 Wrocław, POLAND, Tel. +48 71 320 29 12, E-mail andrzej.kucharski@pwr.wroc.pl (105)
- KUDEKI, Dr. E., University of Illinois, 1406 W. Green St., Urbana, IL, 61801, United States, Tel. (217) 333-4153, E-mail erhan@illinois.edu (110)
- KUDELA, Prof. K., Institute of Experimental Physics, Slovak Academy of Science, Watsonova 47, KOSICE 040 01, SLOVAKIA, Tel. +421 55-622 4554, Fax +421 55-633 6292, E-mail kkudela@kosice.upjs.sk (108)
- KULAH, Assoc. Prof. H., Faculty of Engineering, Middle East Technical University, Balgat, Ankara 06531, TURKEY, Tel. +312 210 2345, E-mail kulah@metu.edu.tr (106)
- KULEMIN, Prof. G.P., Institute of Radiophysics and Electronics, NASU, 12, ac. Proskura Str., KHARKOV 61085, UKRAINE, Tel. +380 572-448508, E-mail sekretar@ire.kharkov.ua (107)
- KULPA, Prof. K. K., Warsaw University of Technology, ul. Nowowiejska 15/19, 00-665 WARSAW, POLAND, Tel. +48 606 209 225, E-mail kulpa@ise.pw.edu.pl (107)
- KUROCHKIN, Dr. A.P., NPO VEGA, Kutuzovskiy Prospekt 34, MOSCOW 121170, RUSSIA, Tel. +7 499 249 4308, Fax +7 499 258 2504, E-mail kurochkin@vega.su (105)
- KURUM, Dr. M., Department of Electrical and Computer Engineering, The George Washington University, 800 22nd Street NW, Washington, DC 20052, USA, Tel. +1 202 994 6080, E-mail mkurum@gmail.com (107, 113)
- KUSTER, Prof. N., IT'IS Foundation, Zeughausstraße 43, CH-8004 ZÜRICH, SWITZERLAND, Tel. +41 44 245 96 96, Fax +41 44 245 96 99, E-mail nk@itis.ethz.ch (109)
- KUZMAK, Dr. O.M., Institute of Magnetism, NASU, 36-b, Vernadsky Blvd., KIEV 03142, UKRAINE, Tel. +380 44-4249095, Fax +380 44 4241020, E-mail kuzmak@imag.kiev.ua (112)
- KUZNETSOV, Prof. Yu. V., Theoretical Radio Engineering Department, State Technical University, Moscow Aviation Institute, Volokolamskoe shosse 4, GSP-3, MOSCOW 125993, RUSSIA, Tel. +7 499 158 68 39, Fax +7 499 158 68 39, E-mail kuznetsov@mai-trt.ru, kuznetsov@ieee.org (106)

KYRIACOU, Prof. G.A., Lab. of Microwaves, Dept. of Electrical and Computer Engineering, Demokritos University of Thrace, Vas. Sofias 12, 67 100 XANTHI, GREECE, Tel. +30 5410 795 93, Fax +30 5410 272 64, E-mail gkyriac@ee.duth.gr (105)

LABEAU, Assoc. Prof. F., Associate Dean (Faculty Affairs), McGill Engineering, 3480 University St. #753, Montréal QC, H3A0E9, CANADA, Tel. +1 514 398 7140, E-mail fabrice.labeau@mcgill.ca (104)

LAGASSE, Prof. P., URSI c/o INTEC, Ghent University, Sint-Pietersnieuwstraat 41, B-9000 GENT, BELGIUM, Tel. +32 9-264 33 20, Fax +32 9-264 42 88, E-mail lagasse@intec.ugent.be (104, 113)

LAKHINA, Dr. G.S., FNA Director, Indian Institute of Geomagnetism, Plot No. 5, Sector 18, Kalamboli Highway, kalamboli, NEW PANVEL, 410218, INDIA, Tel. +91 22 27400700 (O), Fax +91 22 27450703, E-mail lakhina@iigs.iigm.res.in, gslakhina@gmail.com (108, 112)

LANG, Dr. R.H., Dept of Electrical Eng. & Computer Science, George Washington University, Phillips Hall, Washington, DC 20052, USA, Tel. +1 202-994-6199, Fax +1 202-994-0227, E-mail lang@gwu.edu (104, 113)

LARKINA, Prof. V.I., IZMIRAN, Moscow Region, TROITSK, MOSCOW REGION 142092, RUSSIA, Tel. +7 496 751 9742, Fax +7 496 751 0124, E-mail larkina@izmiran.ru (107)

LAURENSEN, Dr. D., School of Engineering, The University of Edinburgh, , Edinburgh EH9 3JL, UNITED KINGDOM, Tel. +44 131 650 5579, Fax +44 131 650 6554, E-mail dave.laurenson@ed.ac.uk (106)

LAZAROV, Prof. A., Bourgas Free University (BFU), , 62 San Stefano Str., BG-8000 Bourgas, BULGARIA, Tel. +359 56 900 485, E-mail lazarov@bfu.bg (105)

LE, Dr. H.L., Institut National de la Recherche Scientifique (INRS), University of Quebec, 800 de la Gauchetière West, Suite 6900, Montreal, QC, H5A 1K6, CANADA, Tel. 1-514-228-7015 , E-mail le@emt.inrs.ca (106)

LE VINE, Dr. D., Goddard Space Flight Center, Nasa, Code 614.18800 Greenbelt Road, 20771 Greenbelt, United States, Tel. 301 614 5640, E-mail David.M.LeVine@nasa.gov (110)

LEE, Prof. J-S, Research Center for Integrative Neuroimaging and Neuroinformatics, National Yang-Ming University, No. 155, Sec. 2, Linong Street, Beitou District, TAPEI 112, TAIWAN, Tel. +886 2 28267134, Fax +886 2 28224860, E-mail jslee@ym.edu.tw (109)

LEE, Prof. L-C, President Office, National Central University, No. 300, Jhongda Road, Jhongli City, Taoyuan, CHUNG-LI, TAOYAN 320, CHINA (SRS), Tel. +886 3 422 7151ext. 57000, Fax +886 3 425 4842, E-mail loulee@cc.ncu.edu.tw (104, 108, 112)

LEFEUVRE, Prof. F., LPCE/CNRS, 3A, av. de la Recherche Scientifique, F-45071 Orleans Cedex 2, FRANCE, Tel. +33 2-38-255284, Fax +33 2-38-631234, E-mail lefeuvre@cnrs-orleans.fr (104, 113)

LEITGEB, Prof. N., Institute of Health Care Engineering with European Notified Body of Medical Devices, Graz University of Technology, Kopernikusgasse 24/1, 8010 Graz, AUSTRIA, Tel. +43 316 873 7397, Fax +43 316 873 4412, E-mail norbert.leitgeb@tugraz.at (109)

LEITINGER, Prof. R., Institute for Geophysics, Astrophysics and Meteorology, University of Graz, Universitaetsplatz 5, A-8010 Graz, AUSTRIA, Tel. +43 316 380 5257, Fax +43 316 380 9825, E-mail reinhart.leitinger@kfunigraz.ac.at (110)

LEMEDGE, Dr. B., Heppi, LATMOS-UVSQ-IPSL-CNRS, Quartier Des Garennes 11 Boulevard D'alembert, 78280 Guyancourt, 78280 Guyancourt, France, Tel. +331 80285070, Fax +33 1 80 285297, E-mail bertrand.lemedge@latmos.ipsl.fr (110)

LEYSER, Dr. T.B., Swedish Institute of Space Physics, Uppsala Division, Box 537, SE-75121 Uppsala, SWEDEN, Tel. +46 18-4715941, Fax +46 18-4715905, E-mail Thomas.Leyser@irfu.se (108)

LI, Dr. L., School of EECS, Peking University, ROOM 2843N, Science Building#2, Beijing 100871, CHINA CIE, Tel. +86-10-62754409-2, Fax +86-10-62754409, E-mail lianlin.li@pku.edu.cn (105, 113)

LI, Dr. W., UCLA, 7127 Math Sciences Bldg., 405 Hilgard Ave., Los Angeles, CA, 90095, United States, E-mail moonli@atmos.ucla.edu (108, 113)

LICHTENBERGER, Dr. J., Eötvös University, Pazmany Peter Setany 1/a, H-1111 Budapest, HUNGARY, Tel. +36 1 209 0555 x6654, Fax +36 1 372 2927, E-mail lityi@sas.elte.hu (108, 113)

LIEVENS, Mrs. I., URSI, c/o INTEC, Sint-Pietersnieuwstraat 41, B-9000 GENT, BELGIUM, Tel. +329-264.33.20, Fax +329-264.42.88, E-mail ingeursi@intec.ugent.be (104)

LIGTHART, Prof. Dr. Ir. L.P., Director IRCTR, Delft University, Microwaves Laboratory, Mekelweg 4, NL-2628 CD Delft, NETHERLANDS, Tel. +31 15-278 1034, Fax +31 15-278 4046, E-mail leoligthart@kpnmail.nl (107)

LILJE, Prof. P., Institute of Theoretical Astrophysics, University of Oslo, P.O. Box 1029 Blindern, N-0315 OSLO, NORWAY, Tel. +47 22 856517, E-mail per.lilje@astro.uio.no (109)

LIN, Prof. J.C., Electrical Eng. & Computer Science (M/C 154), University of Illinois at Chicago, 851 South Morgan Street, Chicago, IL 60607-7053, USA, Tel: +1-312413-1052, Fax: +1-312413-0024, E-mail: lin@uic.edu (113)

LIN, Dr. K-H, Dept. of Electrical Engineering, National Sun Yat-Sen University, 70 Lien Hai Road, KAOHSIUNG 80424, CHINA SRS, Tel. +886 7 5252000 ext 4165, E-mail khlin@mail.nsysu.edu.tw (107)

LIN, Mr. R-H, , Chinese Institute of Electronics, P.O. Box 165, Beijing 100036, CHINA CIE, Tel. +86 10 6827 6577, E-mail lin_runhua@ciecloud.org.cn (112)

LINDQVIST, Dr. M., Onsala Space Observatory, Chalmers University of Technology, , SE-439 92 ONSALA, SWEDEN, Tel. +46 31 772 55 08, Fax +46 31 772 55 90, E-mail Michael.Lindqvist@chalmers.se (109)

- LISZT, Dr. H.S., NRAO, 520 Edgemont Road, Charlottesville VA 22903-2475, USA, Tel. +1 434 227 6356, Fax +1 434 296 0278, E-mail hliszt@nrao.edu (113)
- LITOVCHENKO, Prof. V.G., Institute of Physics of Semiconductors, NASU, prosp. Nauki 45, KIEV 03039, UKRAINE, Tel. +380 44-265-6290, Fax +380 44-265-8342, E-mail mickle@semicond.kiev.ua (106)
- LITSYN, Dr. S., Dept. Electrical Eng./Faculty of Engineering, Tel Aviv University, Ramat-Aviv, 69978 TEL AVIV, ISRAEL, Tel. +972 3-631 4139, Fax +972 3-642 3508, E-mail litsyn@eng.tau.ac.il (106)
- LIU, Dr. M., 514th Institute, China Academy of Space Technology, Zhichun Road, Haidan District, BEIJING 100086, CHINA (CIE), Tel. +86 10 687 44 667, Fax +86 10 683 78 158, E-mail run_low@sina.com (105)
- LO, Dr. T.H., National Physical Laboratory, Hampton Road, Teddington TW11 0LW, UNITED KINGDOM, Tel. +44 020 8943 6508, E-mail tian.loh@npl.co.uk (105)
- LOPEZ MARTIN, Prof. M.E., Departamento de Ciencias Morfológicas, Facultad de Medicina, Universidad de Santiago de Compostela, 15782 Santiago de Compostela, SPAIN, Tel. +34 881 812310, Fax +34 981 582642, E-mail melena.lopez.martin@usc.es (109)
- LUISE, Prof. M., Department of Information Engineering, University of Pisa, Via Diotisalvi 2, I-56122 PISA, ITALY, Tel. +390 50-569662, Fax +390 50-568522, E-mail marco.luise@iet.unipi.it (104)
- M**AEKAWA, Prof. Y., Osaka Electro-Communication University, 18-8 Hatsucho, Neyagawa Osaka 572-8530, JAPAN, E-mail maekawa@maelab.osakac.ac.jp (107)
- MAHARAJ, Mr. B.T.J., Department of Electrical, Electronic and Computer Engineering, University of Pretoria, 0002 Pretoria, SOUTH AFRICA, Tel. +27 12 420 4636, E-mail sunil.maharaj@up.ac.za (106)
- MAHMOUD, Prof. I.I., Atomic Energy Authority, Engineering Dept., NRC, Cairo, EGYPT, E-mail imbabyisma@yahoo.com (108)
- MAITRA, Prof A.J.S., Institute of Radio Physics, University of Calcutta, 92 Acharya Prafulla Chandra Road, Kolkata, WB, 700009, India, Tel. +91 33 23509115, E-mail animesh.maitra@gmail.com (107)
- MANARA, Prof G., Dipartimento di Ingegneria dell'Informazione, Università di Pisa, Via G. Caruso 16, 56122 Pisa, Italy, Tel. +39-050-2217552, Fax +39-050-2217522, E-mail g.manara@iet.unipi.it (104)
- MANEUX, Prof. C., IMS, Laboratoire d'Intégration du Matériau au Système, Université Bordeaux 1, 351, Cours de la Libération, F-33405 TALENCE Cedex, FRANCE, Tel. +33 5 40 00 28 58, Fax +33 5 56 37 15 45, E-mail cristell.maneux@ims-bordeaux.fr (106)
- MANN, Appl. Prof. Dr. G., Leibniz Institut fuer Astrophysik Potsdam (AIP), An der Sternwarte 16, D-14482 POTSDAM, GERMANY, Tel. +49(0)331 7499292, Fax +49(0)331 749 9352, E-mail gmann@aip.de (108)
- MANNINEN, Dr. A., VTT, MIKES Metrology, Tekniikantie 1, 02150 Espoo, FINLAND, Tel. 358405148658, E-mail antti.manninen@vtt.fi (105)
- MANSO, Prof. M.E., Centro de Fusão Nuclear do IST, Avenida Rovisco Pais, 1049 LISBOA CODEX, PORTUGAL, Tel. +351 21 841 76 96, E-mail emilia@cfn.ist.utl.pt (108)
- MARKSTROM, Mr. K.-A., AF Technology AB, SE-169 99 STOCKHOLM, SWEDEN, Tel. +46 10 505 40 62, Fax +46 10 505 00 10, E-mail karlarne.markstrom@afconsult.com (106)
- MARROCCO, Dr. G., Dipartimento di Informatica Sistemi e Produzione, University of Roma Tor Vergata, Via del Politecnico, 1, 00133 Roma, ITALY, E-mail marrocco@disp.uniroma2.it (110)
- MARTIN RODRIGUEZ, Prof. E., Facultad de Química - Dpto. Física, Universidad de Murcia Apdo. 4021, 30071 ESPINARDO, MURCIA, SPAIN, Tel. +34 968 367373, Fax +34 968 364148, E-mail ernesto@um.es (105)
- MARZANO, Prof. F.S., DIET - Dept. of Information Eng., Sapienza University of Rome, Via Eudossiana 18, 00184 Rome, Italy, Tel. +39 06 44585847, E-mail marzano@diet.uniroma1.it, fmarzano@aquila.infn.it (110)
- MATERASSI, Dr. M., ISC, National Research Council, via Madonna del Piano 10, 50019 Sesto Fiorentino, ITALY, E-mail massimo.materassi@fi.isc.cnr.it (108)
- MATHEWS, Prof J.D., Communications and Space Sciences Lab (CSSL), The Pennsylvania State University, 323A, EE East, University Park, PA 16802-2707, USA, Tel. +1(814) 777-5875, Fax +1 814 863 8457, E-mail JDMathews@psu.edu (104, 113)
- MATHIS, Prof. Dr. W., Institute of Theoretical Electrical Engineering, Leibniz Universität Hannover, Appelstrasse 9A, D-30167 HANNOVER, GERMANY, Tel. +49 511 762 3201, Fax +49 511 762 3204, E-mail mathis@tet.uni-hannover.de (112)
- MATSUMOTO, Prof. H., President, Kyoto University, Yoshida-Honmachi, Sakyo-ku, KYOTO 606-8501, JAPAN, Tel. +81 75 753 2001, Fax +81 75 753 2091, E-mail matsumoto@hq.kyoto-u.ac.jp (110)
- MAYORGA MONTOYA, Ing. M., Departamento de Ingeniería, Universidad Católica del Perú, Sección Ingeniería de las Telecomunicaciones, Av. Universitaria 1801, San Miguel, LIMA 32, PERU, Tel. +51-1-626-2452, Fax +51-1-626-2116, E-mail mayorga.ma@pucep.edu.pe (105)
- MAZANEK, Prof. M., Faculty of Electrical Engineering, Czech Technical University, Technická 2, PRAGUE 6 16627, CZECH REPUBLIC, Tel. +420 224 352 282, Fax +420 233 339 958, E-mail mazanekm@feld.cvut.cz (112)
- MAZZA, Ing. H.F., INTI, CC. 157, 1650 SAN MARTIN - B.A., ARGENTINA, Tel. +54 1-753 4064, Fax +54 1-755 2102 (105)
- McCARTHY, Dr. K., Dept. of Electrical and Electronic Engineering, University College Cork, CORK, IRELAND, Tel. +353 21 490 2214, Fax +353 1 283 0921/830 921, E-mail K.McCarthy@ucc.ie (107)
- MCCREA, Dr. William, Space Science And Technology, Rutherford Appleton Laboratory, Building R25, Room

- 1.05, Harwell Science And Innovation Centre, OX136BL Harwell, United Kingdom, Tel. +441235446513, Fax +441235445848, E-mail ian.mccrea@stfc.ac.uk (110)
- McCREADY, Ms. M., The Center for Geospace Studies, SRI International, 333 Ravenswood Avenue, Menlo Park, CA 94025, USA, Tel. +1 650 859 5084, Fax +1 650 322 2318, E-mail mary.mccready@sri.com (110)
- McKINNELL, Dr. L.A., South African National Space Agency (SANSA), Space Science, P.O. Box 32, 7200 HERMANUS, SOUTH AFRICA, Tel. +27 28 312 1196, Fax +27 28 312 2039, E-mail lmckinnell@sansa.org.za, lmckinnell@hmo.ac.za (111, 112)
- MEDINA-MENA, Prof. F., Departamento de Electronica y Electromagnetismo, Facultad de Fisica, Universidad de Sevilla, Av. Reina Mercedes s/n, 41012 SEVILLA, SPAIN, Tel. +34 954 553891, Fax +34 954 239434, E-mail medina@us.es (105)
- MENDES, Eng. M.L., ANACOM, Av. José Malhoa 12, 1099-017 Lisboa, PORTUGAL, Tel. +351 21 721 2222, Fax +351 21 721 1006, E-mail ursi.por@anacom.pt (112)
- MICHELSON, Prof. David G., UBC Radio Science Lab, 2356 Main Mall, Vancouver, BC V6T 1Z4, CANADA, Tel. +1 604 822 3544, Fax +1 604 822 5949, E-mail davem@ece.ubc.ca (107)
- MISHRA, Dr. A., Electrical Engineering, Menzis Building, University of Cape Town, Rondebosch 7701, SOUTH AFRICA, E-mail akmishra@ieee.org (107, 110)
- MITCHELL, Dr. C.N., Electronic and Electrical Engineering, University of Bath, Clavertown Down, BATH, BA2 7AY, UNITED KINGDOM, Tel. +44 1225 82 66 10, Fax +44 1225 82 63 05, E-mail c.n.mitchell@bath.ac.uk (110)
- MODELSKI, Prof. J., Institute of Radioelectronics, Warsaw University of Technology, ul. Nowowiejska 15/19, 00-665 WARSAW, POLAND, Tel. +48 22 825 39 29, Fax +48 22 825 5248, E-mail j.modelski@ire.pw.edu.pl (112)
- MOGHADDAM, Prof. Mahta, Dept. of Electrical Engineering, University of Southern California, 3737 Watt Way, Los Angeles, CA 90089 0271, USA, Tel. +1 213 740 4712, Fax +1 213 740 8677, E-mail mahta@usc.edu (109)
- MOITRA, Dr. A., Indian National Science Academy, Bahadur Shah Zafar Marg, NEW DELHI, 110 002, INDIA, Tel. +91 11-322 1931/1950, Fax +91 11-323 5648/1095, E-mail (112)
- MOJABI, Prof. P., Room E3-504B, EITC Building, Electrical and Computer Engineering Department, University of Manitoba, Winnipeg, R3T5V6, Canada, Tel. +1 204 474 6754, Fax +1 204 261 4639, E-mail Puyan.Mojabi@umanitoba.ca (107, 109, 113)
- MOLINACUBEROS, Prof. G.J., Dpto. Electromagnetismo y Electronica, Facultad de Quimica, Universidad de Murcia, 30100 Espinardo, MURCIA, SPAIN, Tel. +34 868 887533, Fax +34 868 884 148, E-mail gregomc@um.es (107)
- MOLINAFERNANDEZ, Dr. I., Departamento de Ingenieria de Comunicaciones, E.T.S.I. Telecomunicacion, Universidad de Malaga, Campus Universitario de Taetos s/n, E-29071 MALAGA, SPAIN, Tel. +34 952 13 13 11, Fax +34 952 13 20 27, E-mail imolina@uma.es (106)
- MOND, Prof. M., Dept of Electrical and Computer Eng., Ben Gurion University, P.O. Box 653, 84105 BEER SHEVA, ISRAEL, Fax +972 7 6472990, E-mail mond@menix.bgu.ac.il (108)
- MOSIG, Prof. J., STI-ITOP-LEMA-ELB30, Ecole Polytechnique Fédérale de Lausanne, Station 11, CH-1015 Lausanne, SWITZERLAND, Tel. +41 21 693 46 28, Fax +41 21 693 26 73, E-mail Juan.Mosig@epfl.ch (105)
- MURPHY, Prof. A., Dept. of Experimental Physics, National University of Ireland Maynooth, CO. KILDARE, IRELAND, Tel. +351 1 6285 222 ext. 209, Fax +351 1 708 3771, E-mail anthony.murphy@nuim.ie (109)
- MURPHY, Prof. P., Dept. of Electrical Eng. & Microelectronics, National University of Ireland, CORK, IRELAND, Tel. +353 21 490 2214, Fax +353 21 427 1698, E-mail P.Murphy@ucc.ie (105)
- MUSHA, Dr. M., Institute for Laser Science, University of Electro-communications, 1-5-1 Chofugaoka, Chofu-shi, TOKYO 182 8585, JAPAN, Tel. +81 424 435 705, Fax +81 424 858 960, E-mail musha@ils.uec.ac.jp (105)
- N**AGY, Dr. L., Department of Broadband Infocommunication Systems, BME - Budapest University of Technology and Economics, Goldmann Gyorgy ter 3, 1111 BUDAPEST, HUNGARY, Tel. +36 1 463 15 59, Fax +36 1 463 32 89, E-mail nagy@mht.bme.hu (106, 112)
- NAH, Prof. W., School of Electronic & Electrical Engineering, Sungkyunkwan University, 2066, Seobu-ro, Jangan-gu, Suwon, Gyeonggi-Do, 440-746, SOUTH KOREA, Tel. +82 31 290 7136, Fax +82 502 302 0878, E-mail wsnah@skku.edu (107)
- NAM, Prof. S., School of Electrical & Computer Engineering, Seoul National University, Sillim-dong, Kwanak-gu, SEOUL 151-742, SOUTH KOREA, Tel. +82 2 880 8412, Fax +82 2 880 8212, E-mail snam@snu.ac.kr (104, 105, 112)
- NAPIERALSKI, Prof. A., Faculty of Electrical, Electronic, Computer and Control Engineering, Technical University of Lodz, 221/223 Wolczanska Street, 90-924 LODZ, POLAND, Tel. +48 42 3127 27, E-mail napier@dmcs.p.lodz.pl (106)
- NEMIROVSKY, Prof. Y., Dept. of Electrical Engineering, Technion - Israel Institute of Technology, 32000 HAIFA, ISRAEL, Tel. +972 4-829 3450, Fax +972 4-832 3041, E-mail nemirov@ee.technion.ac.il (106)
- NENCHEV, Prof. M., Technical University of Sofia, , 8, Kliment Ohridi Str., 1756 SOFIA, BULGARIA, Tel. +359 32659711, E-mail marnenchev@yahoo.com (106, 112)
- NEVES, Prof. Dr. J.C. da Silva, Instituto de Telecomunicações, Universidade de Aveiro, Campus Universitario, 3810-193 AVEIRO, PORTUGAL, Tel. +351 23 437 7900, Fax +351 23 437 7901, E-mail jneves@av.it.pt (107)
- NEWKIRK, Dr. Michael H., Applied Physics Laboratory, The Johns Hopkins University, 11100 Johns Hopkins Road, Laurel, MD 20723, USA, Tel. +1 240 228 6976, Fax +1 240 228 5494, E-mail Michael.Newkirk@jhuapl.edu (107)
- NGWENYA, Ms. L., Programme Officer, SA International Council for Science, Meiring Naude Road Brummeria,

P.O. Box 2600, PRETORIA 0001, SOUTH AFRICA, E-mail lynn.ngwenya@nrf.ac.za (112)

NICKOLAENKO, Prof. A., Remote Sensing, Inst. for Radio-Physics and Electronics Nat. Acad. of Sciences of the Ukraine, 12 Acad. Proskura street, KHARKOV 61085, UKRAINE, Tel. +38 (057) 720 3369, Fax +38 (257) 315 2105, E-mail sasha@ire.kharkov.ua, sashanickolaenko@gmail.com (110)

NICKOLOV, Prof. E., National Institute of Geophysics, Geodesy and Geography, Bulgarian Academy of Sciences, Acad. G. Bonchev St., bl. 3, 1113 SOFIA, BULGARIA, Tel. +359 2 987 4624, E-mail eugene.nickolov@cu.bas.bg (107)

NING, Prof. B., Institute of Geology and Geophysics, Chinese Academy of Sciences, Laboratory for Space Environment Probing, CHINA, E-mail nbq@mail.iggcas.ac.cn (110)

NOEL, Prof. Fernando, Depto de Astronomia, Universidad de Chile, Casilla 36-D, SANTIAGO, CHILE, Tel. +56 2-229 4002, Fax +56 2-229 4101, E-mail fnoel@das.uchile.cl (105)

NOVAK, Dr. J., Institute of Electrical Engineering, Slovak Academy of Sciences, Dubravská cesta 9, BRATISLAVA 84104, SLOVAKIA, Tel. +421 2-59222761, Fax +421 2-54775816, E-mail jozef.novak@savba.sk (106)

O'BRIEN, Ms. Meaghan, National Committees Officer/Fasas Secretariat, Australian Academy of Science, Ian Potter House, Gordon Street, Box 783, Acton ACT 2601, AUSTRALIA, Tel. 02 6201 9456, Fax 02 6201 9494, E-mail meaghan.obrien@science.org.au (112)

O'DROMA, Dr. M., Director Telecommunications Research Centre, Dept. of Electrical & Computer Eng., Electrical and Computer Eng Dept, University of Limerick, LIMERICK, IRELAND, Tel. +353-61-202364, Fax +353-61-338176, E-mail mairtin.odroma@ul.ie (106, 112)

O'SULLIVAN, Dr. J.D., Australian Telescope National Facility, CSIRO Astronomy and Space Science, PO Box 76, Epping, NSW 1710, AUSTRALIA, Tel. +612 9372 4604, E-mail john.osullivan@csiro.au (107)

OH, Prof. Y., School of Electronic and Electrical Engineering, Hongik University, 72-1 Sangsu-Dong, Mapo-Gu, Seoul 121-719, SOUTH KOREA, Tel. +82 2 320 1481, Fax +82 2 320 1193, E-mail yisokoh@hongik.ac.kr (107)

OJO, Dr. J.S., Department of Physics, Federal University of Technology, P.M.B 704, AKURE, NIGERIA, Tel. +234 806 653 2234, E-mail ojojs_74@futa.edu.ng (112)

OKONIEWSKI, Prof. M., Electrical and Computer Engineering, ICT 354, University of Calgary, 2500 University Drive NW, CALGARY, ALBERTA, T2N 1N4, CANADA, Tel. +1 403 220 6175, E-mail okoniews@ucalgary.ca (109)

OMURA, Prof. Y., Laboratory of Computer Space Science, Kyoto University - RISH, Gokasho, Uji, KYOTO 611-0011, JAPAN, Tel. +81 774 38-3811, Fax +81 744 31-8463, E-mail omura@rish.kyoto-u.ac.jp (110)

ONU, Prof. M., Electronics & Computer Technology Unit, Department of Physics, University of Calabar, GPO 2772, Calabar, Cross River State, NIGERIA, Tel. 234 803 507 2076, E-mail michaelonuu@yahoo.com (107)

ÖZEREN, Assist. Prof. F.F., Faculty of Sciences, Erciyes University, Kayseri, TURKEY, Tel. +90 352 207 6666 ext 33256, E-mail ozeren@erciyes.edu.tr (109)

ØSTERBERG, Prof. U., Department of Electronics and Telecommunications, NTNU, O.S. Bragstads plass 2, N-7491 Trondheim, NORWAY, E-mail ulf.osterberg@ntnu.no (105)

PACHECO, Dr. E., Calle Badajoz #169, Mayorazgo IV Etapa - Ate Vitarte, LIMA, PERU, E-mail edgardoepj@gmail.com (112)

PADULA-PINTOS, Prof. V.H., Director Dept. Coord. R&D, Instituto Tecnológico de Buenos Aires, Pena 2446, 7° A", 1125 BUENOS AIRES, ARGENTINA, Tel. +54 1-314 7779 ext. 263, Fax +54 1-314 0270, E-mail (109)

PALOSCIA, Dr. S., CNR-IFAC, Via Madonna del Piano, 10, I - 50019 Sesto Fiorentino, FIRENZE, ITALY, E-mail S.Paloscia@ifac.cnr.it (107)

PANAYIRCI, Dr. E., Dept. of Electr. & Electronics Eng., Kadir Has University, Faculty of Engineering, Cibali Merkez Kampusu, 34230-01 CIBALI, ISTANBUL, TURKEY, Tel. +90 212 533 6532, E-mail eepanay@khas.edu.tr, eepanay@Princeton.edu (106)

PARFITT, Prof. A.J., Pro Vice Chancellor, Division of ITEE, University of South Australia, Mawson Centre, MAWSON LAKES, SA 5095, AUSTRALIA, Tel. +61 8 8302 3310, Fax +61 8 8302 3873, E-mail andrew.parfitt@unisa.edu.au (106)

PARK, Prof. S-O, EE Department, Korea Advanced Institute of Science and Technology, 291 Daehak-Ro, Yuseong-gu, DAEJEON 305-701, SOUTH KOREA, Tel. +82 42 350 7414, Fax +82 42 350 8268, E-mail soparky@kaist.ac.kr (112)

PARKER, Prof. T., Collaborative Nonlinear Electronics Research Facility, Macquarie University, North Ryde, NSW 2109, AUSTRALIA, Tel. +61 2 9850 9131, Fax +61 2 9850 9128, E-mail tonyp@ics.mq.edu.au (106)

PARMENTIER, Dr. J-P, ONERA, DEMR (Electromagnetics & Radar Department), CDE group (Electromagnetic Compatibility & Detection), BP 4025, Avenue Edouard Belin, 31055 TOULOUSE Cedex 4, FRANCE, Tel. +33 5 62 25 27 89, Fax +33 5 62 25 25 77, E-mail hipar@oncert.fr, hipar@onera.fr (110)

PASTORINO, Prof. M., Dept. of Biophysical and Electronic Engineering, University of Genoa, Via Opera Pia 11A, I - 16145 Genova, ITALY, E-mail matteo.pastorino@unige.it (105)

PATRA, Dr. A.K., Dept. of Space, Govt. of India, National MST Radar Facility, PB No. 123, NMRF Guest House, Tirupati, Andhra Pradesh, 517502, India, Tel. 0877-2248805, Fax 08585-272018, E-mail akpatra@narl.gov.in (108)

PAULRAJ, Assoc. Prof. R., Jawaharlal Nehru University, New Mehrauli Road, New Delhi 110067, India, Tel. 91-11-2670 4162, E-mail paulraj@mail.jnu.ac.in (109)

PAZ RETUERTO, Mr. P., Comisión Nacional de Investigación y Desarrollo Aeroespacial CONIDA, Av. Luis Felipe Villarán 1069, San Isidro - LIMA 27, PERU, Fax + 51 1 441 - 9081 (106)

- PEDERSEN, Dr. T., Rvbx1, Air Force Research Laboratory, 29 Randolph Road, 01731 Hanscom Afb, United States, Tel. 781-377-2845, E-mail todd.pedersen@hanscom.af.mil (110)
- PEIXEIRO, Prof. C., Instituto Superior Técnico (Instituto de Telecomunicações), Avenida Rovisco Pais n.º 1, 1049-001 Lisboa, PORTUGAL, E-mail custodio.peixeiro@lx.it.pt (105)
- PELLINEN-WANNBERG, Prof. A., Department of Physics, Umea University, BOX 812, SE-90187 UMEA, SWEDEN, Tel. +46 90 786 74 92, Fax +46 90 786 66 76, E-mail asta.pellinen-wannberg@umu.se (112, 113)
- PELOSI, Dr. G., Information Engineering, University of Florence, Via S. Marta 3, I-50139 FLORENCE, ITALY, E-mail giuseppe.pelosi@unifi.it (113)
- PERSON, Prof. C., Télécom Bretagne, Technopole Brest Iroise, CS 83818, F-29238 BREST Cedex 03, FRANCE, Tel. +33 2 29 00 13 19, Fax +33 2 29 00 13 43, E-mail christian.person@telecom-bretagne.eu (109)
- PIERRARD, Dr. V., Belgisch Instituut voor Ruimte-Aëronomie (BIRA), Ringlaan 3, B-1180 BRUSSEL, BELGIUM, Tel. +32 2 3730 418, Fax +32 2 374 84 23, E-mail viviane.pierrard@aeronomie.be (108, 112)
- PIGNARI, Prof. S.A., Dipartimento Elettrotecnica, Informazione e Bioingegneria, Politecnico di Milano, Piazza Leonardo da Vinci 32, 20133 Milano, Italy, Tel. +39 0223993726, Fax +39 0223993703, E-mail sergio.pignari@polimi.it (107, 110)
- PIJOANVIDAL, Prof. J.L., Dpto. Comunicaciones y Teoría de la Señal, Universidad Ramon Llull, Escuela Técnica Superior de Ingeniería e Informática La Salle, 08022 BARCELONA, SPAIN, Tel. +34 93 290 24 00, Fax +34 93 290 24 70, E-mail joanp@salle.url.edu (108)
- PITOUT, Mr. F., Institut de Recherche en Astrophysique et Planétologie, 9, rue de Colonel Roche, BP 44346, 31028 TOULOUSE Cedex 4, FRANCE, Tel. +33 5 61 55 66 81, E-mail frederic.pitout@irap.omp.eu (108)
- PNG CHING ENG, Dr. J., Director, Electronics & Photonics Department, A*Star Institute of High Performance Computing, 1 Fusionopolis Way, #16-16, Connexis 138632, SINGAPORE, E-mail pngce@ihpc.a-star.edu.sg (106, 112)
- POGORILY, Prof. A.N., Institute of Magnetism, NASU, 36-b, Vernadsky Blvd., KIEV 03142, UKRAINE, Tel. +380 44 4249095, Fax +380 44 4241020, E-mail apogorily@aol.com (112)
- POPOVIC, Prof. Z.B., Dept. of Electrical and Computer Eng., University of Colorado, Rm ECEE1B55, Campus Box 425, Boulder, CO 80309-0425, USA, Tel. +1-303 492-0374, Fax +1-303 492-2758, E-mail zoya.Popovi@colorado.edu (106)
- POULTER, Dr. E. M., National Institute of Water and Atmospheric Research Ltd, NIWA, P.O.Box 14-901, Kilbirnie, Wellington, NEW ZEALAND, Tel. +64-4-386-0560, Fax +64-4-386-2153, E-mail m.poulter@niwa.cri.nz (107)
- PRASAD, Dr. M.V.S.N., Radio & Atmospheric Sciences, National Physical Laboratory, Dr KS Krishnan Marg, New Delhi 110012, INDIA, E-mail mvprasad@nplindia.org (106)
- PRATO, Dr. F., Lawson Imaging, Room B5-004, Lawson Health Research Institute, 268 Grosvenor Str., LONDON, ON N6A 4V2, CANADA, Tel. +1 519-646-6100x64140, Fax +1 519-646-6205, E-mail prato@lawsonimaging.ca (112)
- PRAZERES, Eng. H. P., ICP-ANACOM, Av. José Malhoa 12, 1099-017 LISBOA, PORTUGAL, Tel. +351 21 721 2232, Fax +351 21 721 1006, E-mail ursi.por@anacom.pt, helena.prazeres@anacom.pt (112)
- PRICE, Prof. C.G., Geophysics and Planetary Sciences, Tel Aviv University, Levanon Road, 69978 Tel Aviv, Israel, Tel. +972-36406029, Fax +972-3-6409282, E-mail cprice@flash.tau.ac.il (110)
- PRIOU, Dr. A., LEME, University Paris Ouest Ville d'Avray, 50 rue de Sèvres, 92794 Ville d'Avray, FRANCE, Tel. +33 1 40 97 41 00, E-mail alainpriou@orange.fr (105)
- PULINETS, Prof. S.A., IZMIRAN, Russian Academy of Sciences, Troitsk, Moscow Region 142190, RUSSIA, E-mail pulyal@hotmail.com (110)
- QUIJANO**, Prof. A., Calle 48 y 116, 1900 LAPLATA, B.A., ARGENTINA, Tel. (54) 21-243 709, Fax (54) 21-250 804, E-mail adrian.quijano@gmail.com (106)
- RABIU**, Dr. A.B., Department of Physics, Federal University of Technology, Akure, Ondo State, NIGERIA, Tel. 234 803 070 5787, E-mail tunderabiu@yahoo.com (105, 108)
- RACHIDI, Prof. F., EPFL-SCI-STI-FR, ELL-138, Station 11, CH-1015 Lausanne, Switzerland, Tel. +41-21-693 26 20, Fax +41-21-693 46 62, E-mail Farhad.Rachidi@epfl.ch (107, 110, 112)
- RADASKY, Dr. W.A., Metatech Corporation, 358 S. Fairview Ave., Suite E, Goleta, CA 93117, USA, Tel. +1-805-683-5681, Fax +1-805-683-3023, E-mail Wradasky@aol.com (110)
- RADEV, Prof. D., Ruse University, Angel Kanchev, 8 Studentska str., 7017 RUSE, BULGARIA, Tel. +359 82 888 673, E-mail dradev@abv.bg (107)
- RADICELLA, Prof. S.M., Julian Alvarez 1210, 1414 BUENOS AIRES, ARGENTINA, Tel. +54 1-772-1471, Fax +54 11 4776 0410, E-mail postmast@caerce.edu.ar (108)
- RADICELLA, Prof. S.M., Abdus Salam ICTP, ARPL, Strada Costiera 11, PO Box 586, I-34014 TRIESTE, ITALY, Tel. +390 40 224 0331, Fax +390 40 224 604, E-mail sandro.radicella@ictp.trieste.it, rsandro@ictp.it (108)
- RAKOV, Prof. V., Ece, University of Florida, 553 Engineering Bldg. #33, Gainesville, FL 32611-6130, USA, E-mail rakov@ece.ufl.edu (110)
- RAMAKRISHNA, Prof. A., Department of Physics, Indian Institute of Technology, Kanpur, Uttar Pradesh, 208 016, India, Tel. +91 512 259 7449, Fax +91 512 259 0914, E-mail sar@iitk.ac.in (106)
- RASMUSSEN, Prof. J., RISOE, Optics & Fluid Dynamics Department, P.O. Box 49, DK 4000 ROSKILDE,

- DENMARK, Tel. +45 4677 4537, Fax +45 4677 4565, E-mail jens.juul.rasmussen@risoe.dk (108)
- RAULIN, Prof. J-P, Escola de Engenharia, Centro de Radio-Astronomia e Astrofisica Mackenzie-CRAAM, Universidade Presbiteriana Mackenzie, Rua da Consolacao 896, Consolacao, 01302-907 Sao Paulo, SP, BRAZIL, Tel. +55 11 21148724, Fax +55 11 21142300, E-mail raulin@craam.mackenzie.br (107)
- READER, Prof. H. Charles, Dept. of Electrical & Electronic Eng., University of Stellenbosch, Banghoek Road 7600, 7602 Stellenbosch, SOUTH AFRICA, Tel. +27 21-808-3623/4478, Fax +27 21-808-4981, E-mail hcreader@sun.ac.za (107, 110)
- REID, Ms. J., International Contracts Coordinator, Royal Society of New Zealand, 11 Turnbull Street, P.O. Box 598, Wellington 6140, NEW ZEALAND, Tel. +64 4 475780, E-mail Josie.Reid@royalsociety.org.nz (112)
- REISING, Prof. S.C., Electrical and Computer Engineering Department, Colorado State University, 1373 Campus Delivery, Fort Collins, CO 80523-1373, USA, Tel. +1 970 491 2228, Fax +1 970 491 2249, E-mail Steven.Reising@ColoState.edu (104, 113)
- RENGARAJAN, Prof. S.R., Electrical And Computer Engineering, California State University, 18111 Nordhoff Street, Northridge, CA 91330-8346, USA, Tel. +1 818 677 3571, Fax +1 818 677 7062, E-mail srengarajan@csun.edu (112)
- RIEH, Prof. J-S, School of Electrical Engineering, Korea University, 145 Anam-ro, Seongbuk-gu, Seoul, 136-713, SOUTH KOREA, Tel. +82 2 3290 3257, Fax +82 2 921 0544, E-mail jsrieh@korea.ac.kr (106)
- ROBINSON, Dr. M.P., Department of Electronics, University of York, Heslington, YORK, YO10 5DD, UNITED KINGDOM, Tel. +44 1904 432 385, Fax +44 1904 433 224, E-mail mpr@ohm.york.ac.uk (109)
- ROCCO GIRALDI, Prof. M.T.M., Instituto Militar de Engenharia - IME, , Praça General Tiburcio 80, Urca, 22290-270 Rio de Janeiro, BRAZIL, Tel. +55 21 3820 4183, Fax +55 21 9641 8217, E-mail mtmrocco@ime.eb.br, mtmrocco@gmail.com (112)
- RODGER, Prof. C.J., Department of Physics, University of Otago, Po Box 56, Dunedin 9016, NEW ZEALAND, Tel. +64 3 479 4120, Fax +64 3-479 0964, E-mail crodger@physics.otago.ac.nz (108, 113)
- RODRIGUES, Prof. Dr. A., Instituto Superior Técnico, Instituto de Telecomunicações, Avenida Rovisco Pais nº1, 1096 LISBOA CODEX, PORTUGAL, Tel. +351 2 8418484, E-mail antonio.rodrigues@lx.it.pt (106)
- RODRIGUEZ-GONZALEZ, Prof. J.A., Dpto. Fisica Aplicada, Facultad de Fisica, Universidad de Santiago de Compostela, 15782 Santiago de Compostela, SPAIN, Tel. +34 8818 140 30, Fax +34 8818 140 72, E-mail ja.rodriguez@usc.es (112)
- ROGIER, Prof. H., Information Technology, Ghent University, Sint-Pietersnieuwstraat 41, B-9000 Ghent, Belgium, Tel. (329) 264-3343, Fax (329) 264-9969, E-mail hendrik.rogier@intec.ugent.be (105)
- RÖNNKLEIV, Prof. Arne, Department of Electronics and Telecommunications, NTNU, O.S. Bragstads plass 2, N-7491 TRONDHEIM, NORWAY, Tel. +47 73-594413, E-mail arne.ronnekleiv@iet.ntnu.no (106)
- ROTHKAEHL, Dr. H., Space Research Center, Polish Academy of Sciences, Bartycka 18 A, 01-716 Warsaw, Poland, Tel. +48 22 196 64 18, E-mail hrot@cbk.waw.pl (108, 110)
- ROZTOCIL, Dr. J., Faculty of Electrical Engineering, Czech Technical University, Technická 2, PRAGUE 6 16627, CZECH REPUBLIC, Tel. +420 224 352 869, Fax +420 233 339 929, E-mail roztočil@feld.cvut.cz (105)
- RUBINSTEIN, Prof. M., HEIG-VD, Route de Cheseaux 1, 1400 Yverdon-les-Bains, SWITZERLAND, Tel. +41 24 557 6296, E-mail marcos.rubinstein@heig-vd.ch (106)
- RUCKER, Prof. H.O., Space Research Institute, Schmiedlstrasse 6, 8042 Graz, AUSTRIA, Tel. +43 316 4120 601, Fax +43 316 4120 690, E-mail rucker@oeaw.ac.at (108, 109, 112)
- RUZHIN, Dr. Y., IZMIRAN Russian Academy of Science, IZMIRAN, 142190 MOSCOW TOITSK, RUSSIA, E-mail ruzhin@izmiran.ru (108)
- RYDBERG, Prof. A., Angstrom Laboratory, Uppsala University, Dept. of Engineering Sciences, P.O. Box 534, SE-751 21 UPPSALA, SWEDEN, Tel. +46 18 471 32 28, Fax +46 18 55 50 95, E-mail anders.rydberg@angstrom.uu.se (106)
- S**AAD, Prof. E.M., Faculty of Engineering, Helwan University, , Helwan, Cairo, EGYPT, Tel. +202 5048291, Fax +202 2558294, E-mail elsayedmos@hotmail.com (107, 112)
- SABATH, Dr. F., Wehrwissenschaftliches Institut fuer Schutztechnologien, ABC-Schutz, GB 300, Humboldtstrasse 100, D-29623 MUNSTER, GERMANY, Tel. +49 (0)5192 136 300, Fax +49 (0)5192 136 355, E-mail FrankSabath@bundeswehr.org (107, 110)
- SADKHAN, Bay S.B., Chairman of IEEE, Iraq section, University of Babylon, Computer Technology College, Babylon, Iraq, Tel. 00964 7707119529, Fax 00964 7801884154, E-mail drengsattar@yahoo.com (112)
- SAKA, Prof. B., Dept. of Electrical & Electronics Engineering, Hacettepe University, Faculty of Engineering, , 06532 BEYTEPE, ANKARA, TURKEY, Tel. +90 312 297 7045, Fax +90 312 299 2125, E-mail birsen@hacettepe.edu.tr (112)
- SALOUS, Prof. S., School of Engineering, Centre for Communication Systems, University of Durham, South Road, DURHAM, DH1 3LE, UNITED KINGDOM, Tel. +44 191 334 2532, Fax +44 191 334 2407, E-mail sana.salous@durham.ac.uk (106)
- SAMARAS, Prof. T., Dept. of Physics, Radiocommunications Lab., Aristotle University of Thessaloniki, GR-54124 THESSALONIKI, GREECE, Tel. +30 2310 998232, Fax +30 2310 998069, E-mail theosama@auth.gr (112)
- SANCHO RUIZ, Prof. M., Dep. Fisica Aplicada III - Fac. de Fisicas, Universidad Complutense, 28040 MADRID, SPAIN, Tel. +34 91 394 4388, Fax +34 91 394 5196, E-mail msancho@fis.ucm.es (108)

- SANTOLIK, Assoc. Prof. O., Institute of Atmospheric Physics, Academy of Sciences of the Czech Republic, Bocni II, 1401, 141 31 PRAGUE 4, CZECH REPUBLIC, Tel. +420 267 103 083, Fax +420 272 762 528, E-mail os@ufa.cas.cz, santolik@gmail.com (104, 108, 113)
- SARANGO, Dr. Martin F., M Sarango CT, Industrias Tecnológicas, Av. Javier Prado Este 3040 Piso 4, San Borja, LIMA 41, PERU, Tel. +51 1-3588700, Fax +51 1-2500969, E-mail ursiperu@msarangoct.com (107)
- SCHILIZZI, Prof. R.T., School of Physics and Astronomy, University of Manchester, Alan Turing Building, Manchester M13 9PL, UNITED KINGDOM, Tel. +44 (0) 161 306 9663/9400, E-mail Richard.Schilizzi@manchester.ac.uk (113)
- SCHLEGEL, Prof. Kristian, Copernicus Gesellschaft e.V., Max-Planck-Str. 13, D-37191 KATLENBURG-LINDAU, GERMANY, Tel. +49 5556-979451/468, Fax +49 5556-979240, E-mail kristianschlegel@web.de, KS-URSI@email.de (104, 110)
- SCHÖNHUBER, Dr. M., Joanneum Research, Space and Acoustics, DIGITAL – Institute of Information and Communication Technologies, Steyrgasse 17-19, 8010 Graz, AUSTRIA, Tel. +43 316 876 2511, Fax +43 316 8769 92511, E-mail Michael.Schoenhuber@joanneum.at (107)
- SCHRADER, Dr. T., Dept. High Frequency and Fields, Physikalisch-Technische Bundesanstalt, Bundesallee 100, D-38116 BRAUNSCHWEIG, GERMANY, Tel. +49 (0)531 592-2200, Fax +49 (0)531 592-2205, E-mail thorsten.schrader@ptb.de (105)
- SCHWEICHER, Prof. E., 79, rue de Bruxelles, 1480 TUBIZE, BELGIUM, Tel. +32 2 355 0636, E-mail schweicher.emile@gmail.com (110)
- SEIRADAKIS, Prof. J.H., Department of Physics, Section Astrophysics, Astronomy and Mechanics, Aristotle University of Thessaloniki, GR-54124 THESSALONIKI, GREECE, Tel. +30 2310 998173, Fax +30 2310 995384, E-mail jhs@astro.auth.gr (109)
- SELLER, Dr. R., Department of Broadband Infocommunication Systems, BME-Budapest University of Technology and Economics, Goldman Gyorgy ter 3, 1111 BUDAPEST, HUNGARY, Tel. +36 1 463 3687, Fax +36 1 463 3289, E-mail seller@mht.bme.hu (107)
- SELLERI, Prof. S., Dip. di Ingegneria dell'Informazione, University of Parma, Viale G.P. Usberti 181/A, 43124 Parma, ITALY, E-mail stefano.selleri@unipr.it (106)
- SEN GUPTA, Dr. A., Department of Applied Sciences, The Northcap University, Sector 23 A, Gurgaon, Haryana 122017, INDIA, Tel. 0124 2365811, Fax 0124 2367488 (105)
- SERRA, Dr. R., Technische Universiteit Eindhoven, P.O. Box 513, 5600 MB EINDHOVEN, NETHERLANDS, E-mail r.serra@tue.nl (110, 112)
- SEXTON, Prof. M.C., University College Cork, 6 Brighton Villas, Western Road, CORK, IRELAND, Tel. +353 21 490 2893/2210, Fax +353 21 427 1698, E-mail eleceng@ucc.ie (108)
- SHAFAI, Dr. L., Canadian Space Agency, David Florida Laboratory, 6767 route de l'Aéroport, ST-HUVERT, QC J3Y 8Y, CANADA, Tel. +1 613 990 3204, Fax +1 613 993 6103, E-mail leili.shafai@asc-csa.gc.ca (105)
- SHIBATA, Prof. K., Kwasan Observatory, Kyoto University, Yamashina, KYOTO 607-8471, JAPAN, Tel. +81 75-581 1235, Fax +81 75-593 9617, E-mail shibata@kwasan.kyoto-u.ac.jp (110)
- SHMELEV, Dr. A.B., Radiotechn. Inst. by name of Academic Mints, OAO, 8 Marta Street, bld. 10, MOSCOW 125083, RUSSIA, Tel. +7 495 614 2841, Fax +7 495 614 0662, E-mail abshmelev@yahoo.com (106)
- SCHUHMANN, Prof. Dr. Ing. R., Fakultät IV, Elektrotechnik und Informatik, TU Berlin, Fachgebiet Theoretische Elektrotechnik, Einsteinufer 17, D-10587 Berlin, GERMANY, Tel. +49 (30) 314-22188, E-mail rolf.schuhmann@tu-berlin.de (105)
- SIBILLE, Prof. A., Dept. Comelec, TELECOM ParisTech, 46 rue Barrault, F-75634 Paris Cedex 13, FRANCE, Tel. +33 01 45 81 70 60, Fax +33 01 45 80 40 36, E-mail alain.sibille@telecom-paristech.fr (112)
- SIERRA-CASTAÑER, Prof. M., ETSIT DPCHO. C410, Universidad Politécnica de Madrid, Avenida Complutense 30, SPAIN, E-mail maria@gr.ssr.upm.es, manuel.sierra.perez@upm.es (106)
- SIGALO, Dr. F.B., Department of Physics, Rivers State University of Science and Technology, PMB 5080, Port Harcourt, Rivers State, NIGERIA, Tel. 234 803 342 7133, E-mail fbsigalo@hotmail.com (109)
- SIHVOLA, Prof. A., Dept. Radio Science & Engineering, Aalto University, PO Box 13000, FI-00076 AALTO, FINLAND, Tel. +358 9 470 22261, E-mail Ari.Sihvola@aalto.fi (105, 112)
- SINHA, Prof. S., Department of Electrical, Electronic and Computer Engineering, University of Pretoria, SOUTH AFRICA, Tel. +27 12 420 2950, E-mail saurabh.sinha@up.ac.za (106)
- SJÖBERG, Prof. D., Electrical and Information Technology, Lund Institute of Technology, P.O. Box 118, 22100 LUND, SWEDEN, Tel. +46 46 222 75 11, Fax +46 46 222 75 08, E-mail daniel.sjoberg@eit.lth.se (105)
- SKOU, Prof. N., Electromagnetic Systems, Denmark's Technical University, Oersted Plads, Building 348, DK 2800 LYNGBY, DENMARK, Tel. (454) 525-3768, Fax (454) 593-1654, E-mail ns@space.dtu.dk (107)
- SKVOR, Prof. Z., Faculty of Electrical Engineering, Czech Technical University, Technická 2, PRAGUE 6 166 27, CZECH REPUBLIC, Tel. +420 224 352 278, Fax +420 233 339 958, E-mail skvor@feld.cvut.cz (105)
- SLAVOVA POPIVANOVA, Prof. A., Mathematical Physics, Institute Of Mathematics And Informatics, Bulgarian Academy Of Sciences, Acad.g.bonchev Str., Bl.8, 1113 Sofia, Bulgaria, Tel. +359 2 979 2841, Fax +3592 971 3649, E-mail slavova@math.bas.bg (109)
- SLOBODZIAN, Prof. P., Faculty of Electronics, Wrocław University of Technology, 27 Wybrzeze Wyspianskiego St, 50-370 Wrocław, POLAND, Tel. +48 71 320 4583, E-mail piotr.slobodzian@pwr.wroc.pl (107)
- SMIESKO, Prof. V., Fac. of Electrical Eng. & Information Technology, Slovak University of Technology, Ilkovicova 3, BRATISLAVA 812 19,

- SLOVAKIA, Tel. +421 2-60291894, Fax +421 2-65429600, E-mail viktor.smiesko@stuba.sk (107)
- SMITH, Prof. P.D., Department of Mathematics, Head of Department, Macquarie University, Sydney 2109, AUSTRALIA, Tel. +61 2 9850 8944, Fax +61 2 9850 8114, E-mail paul.smith@mq.edu.au (104, 105, 112)
- SOBIESKI, Prof. P., U.C.L. - TELE, Bâtiment Stévin, Place du Levant, 2, 1348 LOUVAIN-LA-NEUVE, BELGIUM, Tel. +32 10-47 23 03, Fax +32 10-47 20 89, E-mail Piotr.Sobieski@uclouvain.be (107)
- SORRENTINO, Prof. R., Department of Engineering, University of Perugia, Via G. Duranti 93, I-06125 PERUGIA, ITALY, Tel. +390 75-585 3658, Fax +390 75-585 3568, E-mail roberto.sorrentino@unipg.it, r.sorrentino@ieee.org (112)
- SOUSA, Prof. L., Instituto Superior Tecnico (Instituto de Telecomunicações), Avenida Rovisco Pais N°1, 1096 Lisboa Codex, PORTUGAL, E-mail leonel.sousa@lx.it.pt (106)
- STANISLAWSKA, Dr. I., Polish Academy of Sciences, Space Research Centre, ul. Bartycka 18 A, 00-716 WARSAW, POLAND, Tel. +48 22 496 62 01, E-mail stanis@cbk.waw.pl (108, 113)
- STEINMEYER, prof. G., Max-Born-Institut (MBI), Department C2, Haus C, 3.7, Max-Born-Straße 2 A, 12489 Berlin, GERMANY, E-mail steinmey@mbi-berlin.de (106)
- STOFANIK, Dr. V., Faculty of Electrical Eng. & Inf. Technology, Slovak University of Technology, Ilkovicova 3, SK- 81219 Bratislava, SLOVAKIA, Tel. +421 2 602 91 394, Fax +421 2 654 29 683, E-mail vladimir.stofanik@stuba.sk (107, 112)
- STONE, Dr. W.R., 840 Armada Terrace, San Diego, CA 92106, USA, Tel. +1-619 222 1915, Fax +1-619 222 1606, E-mail r.stone@ieee.org (104, 113)
- STRELTSOV, Prof. A., Dept. of Physical Sciences, Embry-Riddle Aeronautical University, 600 S. Clyde Morris Blvd., Daytona Beach, FL 32114, USA, Tel. +1 386 226 7237, Fax +1 386 226 6621, E-mail streltsa@erau.edu (108)
- SU, Dr. D., Beijing University of Aeronautics & Astronautics, XueYuan Road No.37, HaiDian District, Beijing, CHINA (CIE), Tel. +86 10 8231 7224, E-mail sdl@buaa.edu.cn (105)
- SU, Prof. Y-K, Office of Academic Affairs, National Cheng Kung University, No. 1, Ta-Hsueh Road, TAIWAN 701, CHINA (SRS), Tel. +886-6 2757575ext50109, E-mail yksu@mail.ncku.edu.tw (106)
- SUMICHRAST, Prof. L., Fac. of Electrical Eng. & Information Technology, Slovak University of Technology, Ilkovicova 3, BRATISLAVA 812 19, SLOVAKIA, Tel. +421-2-65423502, Fax +421-2-65420415, E-mail lubomir.sumichrast@stuba.sk (105)
- SUN, Assoc. Prof. Zhipei, Department of Micro- and Nanosciences, Aalto University, P.O. Box 13500, 00076 FINLAND, Tel. +358 50 4302 820, E-mail zhipei.sun@aalto.fi (106)
- SUWAIYEL, Dr. M.I., Directorate of International Cooperation, KACST, P.O. Box 6086, RIYADH 11442, SAUDI ARABIA, Tel. +966 1 488 3555 ext 3490, Fax +966 1 481 3441, E-mail int_coop@kacst.edu.sa (112)
- SVOBODA, Dr. M., Czech Metrology Institute, Hvozdanska 3, PRAGUE 4 148 01, CZECH REPUBLIC, Tel. +420 271 192 125, Fax +420 272 934 560, E-mail msvoboda@cmi.cz (107)
- SZEKELY, Prof. V., Department of Electron Devices, BME - Budapest University of Technology and Economics, Goldmann Gy. tér 3., H-1111 BUDAPEST, HUNGARY, Tel. +36 1-463-2703, Fax +36 1-463-2973, E-mail szekely@eet.bme.hu (106)
- SZULAKIEWICZ, Prof. P., Faculty of Electronics & Telecommunications, Poznan University of Technology, 3A Piotrowo Street, 60-965 Poznan, POLAND, E-mail pawel.szulakiewicz@et.put.poznan.pl (106)
- SZYMCZAK, Prof. M., Nicolaus Copernicus, Astronomy Center, University in Torun, Piwnice k/ Torunia, 87 148 Lysomice, POLAND, Tel. +48 56 611 30 33, E-mail msz@astro.umk.pl (109)
- T**AKI, Prof. M., Department of Electrical Engineering, Tokyo Metropolitan University, 1-1 Minami-osawa, Hachioji, TOKYO 192-0397, JAPAN, Tel. +81 426 77 2763, Fax +81 426 772756, E-mail masao@tmu.ac.jp (104)
- TANZI, Prof. Joseph, Institut Mines Telecom, LTCI UMR 5141 CNRS, Telecom Paristech, 46 Rue Barrault, 75 013 Paris, France, Tel. +33 (0)4 93 67 89 16, Fax +33 (0)4 93 957581, E-mail tullio.tanzi@Telecom-ParisTech.fr (104, 113)
- TAO, Dr. R., Department of Electronic Engineering, Beijing Institute of Technology, 5 South Zhongguancun Street, Haidan District, Beijing, 100081, CHINA (CIE), Tel. +0086 10 6891 8332, E-mail rantao@bit.edu.cn (106)
- TAVELLA, Dr. P., INRIM, Strada delle Cacce 91, 10135 Torino, ITALY, Tel. +39 011 3919235, Fax +39 011 3919259, E-mail tavella@inrim.it (112, 113)
- TEDJINI, Dr. S., INPG-ESISAR, LCIS, 50, rue B. de Laffemas, BP 54, F-26902 VALENCE CEDEX 9, FRANCE, Tel. +33 4 75 75 9420, Fax +33 4 75 43 5642, E-mail smail.tedjini@lcis.grenoble-inp.fr (104, 110, 112)
- TERKILDSEN, Dr. M., Australian Bureau of Meteorology, Space Weather Services, P.O. Box 1386, Haymarket NSW 1240, AUSTRALIA, Tel. +61 2 92138044, E-mail m.terkildsen@bom.gov.au (113)
- TERRE, Prof. M., CNAM, EICNAM, 292 rue Saint-Martin, F-75003 Paris Cedex, France, Tel. +33 1 40 27 27 67, E-mail michel.terre@cnam.fr (106)
- THOMSON, Dr. N.R., Department of Physics, University of Otago, P.O. Box 56, DUNEDIN, NEW ZEALAND, Tel. +64 3-479 7802, Fax +64 3-479 0964, E-mail n_thomson@physics.otago.ac.nz (104, 112)
- THURÓCZY, Dr. G., Department of Non-Ionising Radiation, National Research Institute for Radiobiology and Radiohygiene, Anna u.5, H-1221 Budapest, HUNGARY, Tel. +36 1 482 2019, Fax +36 1 482 2020, E-mail thuroczy@hp.osski.hu (109)

- TIAN, Professor J., Intelligent Medical Research Center, Institute Of Automation, Chinese Academy Of Sciences, Rm. 933, No. 95, Zhongguancun East Rd., Haidian District, 100190 Beijing, Haidian District, China, Tel. 86-10-52628760, E-mail tian@ieee.org (109)
- TJELTA, Dr. T., Telenor GBDR, Snaroyveien 30, 1331 FORNEBU, NORWAY, Tel. +47 90 786424, E-mail terje.tjelta@telenor.com (107)
- TOBAR, Prof. M.E., School of Physics M013, Frequency Standards and Metrology Research Group, University of Western Australia, 35 Stirling Highway, CRAWLEY, WA 6009, AUSTRALIA, Tel. +61 8 6488 3443, Fax +61 8 6488 1235, E-mail mike@physics.uwa.edu.au (105)
- TORKAR, Prof. K.M., Space Research Institute, Schmiedlstrasse 6, A 8042 Graz, AUSTRIA, Tel. +43 316 4120 531, Fax +43 316 4120 590, E-mail klaus.torkar@oeaw.ac.at (108)
- TORNİKOSKI, Prof. M., Aalto University, Metsähovi Radio Observatory, Metsähovintie 114, 02540 KYLMÄLÄ, FINLAND, Tel. +358 9-2564 831, Fax +358 9-2564 531, E-mail Merja.Tornikoski@aalto.fi (109)
- TRAINOTTI, Prof. V., Bernardo de Irigoyen 6502° 10, 1072 BUENOSAIRES, ARGENTINA, Tel. +541 4334 3529, Fax +541 4709 3210, E-mail vtrainotti@ieee.org (105)
- TRETYAKOV, Prof. O.A., Department of Theoretical Radio Physics, Kharkov National University, Svoboda Sq. 4, Kharkov 61077, UKRAINE, Tel. +380 572-457163/457257, Fax +380 572-476506, E-mail Oleg.A.Tretyakov@univer.kharkov.ua (105)
- TRICHOPOULOS, Dr. G., Electrical, Computer & Energy Engineering ISTB4 555D, Arizona State University, 781 E Terrace Road, Tempe, AZ 85287, USA, Tel. +1 614 364 2090, Fax , E-mail gtrichop@asu.edu (113)
- TRUHLIK, Dr. V., Department Of Upper Atmosphere, Institute Of Atmospheric Physics, Acad. Sci. Czech Rep., Bocni Ii, 1401, 14131 Praha, Czech Republic, Tel. 00420267103058, E-mail vtr@ufa.cas.cz (111)
- TRULSEN, Prof. J., Institute of Theoretical Astrophysics, University of Oslo, P.O. Box 1029 Blindern, N-0315 OSLO, NORWAY, Tel. +47 22 856540, Fax +47 22 856505, E-mail jan.trulsen@astro.uio.no (108, 112)
- TSIBOUKIS, Prof. T., Division of Telecommunications, Dept. of Electrical & Computer Eng., Aristotle University of Thessaloniki, GR-54124 THESSALONIKI, GREECE, Tel. +30 23 1099 6323, Fax +30 23 1099 6312, E-mail tsibukis@auth.gr (105)
- TSUKAMOTO, Prof. K., Department of Information Networks, Faculty of Information Science and Technology, Osaka Institute of Technology, 1-79-1 Kitayama, Hirakata, Osaka 573-0196, JAPAN, Tel. +81 72 866 5389, Fax +81 72 866 5389, E-mail katsutoshi.tsukamoto@oit.ac.jp (106)
- TU, Dr. Y-K, Chunghwa Telecom Laboratories, , 12, Lane 551, Min-Tsu Road, Sec. 5, TAOYUAN 326, TAIWAN, Tel. +886 3 4244202, Fax +886 3 4244208, E-mail yktu@cht.com.tw (106)
- TZIOUMIS, Dr. A., CSIRO, Australia Telescope National Facility, PO Box 76, EPPING, NSW 2121, AUSTRALIA, Tel. +61 2 9372 4350, Fax +61 2 9372 4310, E-mail Tasso.Tzioumis@csiro.au, atzioumi@atnf.csiro.au (113)
- ÜNAL, Assist. Prof. I., İnönü University, 44280 Malatya, TURKEY, Tel. +90 422 377 4210, E-mail ibrahim.unal@inonu.edu.tr (108)
- UNO, Prof. T., Department of Electrical and Electronic Engineering, Tokyo University of Agriculture and Technology, 2-14-16 Naka, Koganei, Tokyo 184-8588, JAPAN, Tel. +81 42 388 7146, Fax +81 42 388 7146, E-mail uno@cc.tuat.jp (105)
- USLENGHI, Prof. P.L.E., Dept. of ECE (MC 154), University of Illinois at Chicago, 851 S. Morgan Street, CHICAGO, IL 60607-7053, USA, Tel. +1 312 996-6059, Fax +1 312 996 8664, E-mail uslenghi@uic.edu (104)
- USTUNER, Dr. F., TUBITAK UME, TUBITAK Gebze Campus, Baris Mah. Dr. Zeki Acar Cad. No 1, 41470 Gebze KOCAELI, Türkiye, Tel. +90 262 679 5031, Fax +90 262 679 5035, E-mail fatih.ustuner@tubitak.gov.tr (105)
- UZUNOGLU, Prof. N.K., Division of Information Transmission Systems and Material Technology, School of Electrical and Computer Eng., National Technical University of Athens, Iroon Polytechniou 9, GR-15773 ATHENS, GREECE, Tel. +30 210 7722289, E-mail nuzu@cc.ece.ntua.gr (109, 112)
- VAINIO, Prof. R., Head of Space Research Laboratory, Department of Physics and Astronomy, University of Turku, 20014 Turun yliopisto, FINLAND, E-mail rami.vainio@utu.fi (108)
- VAN ARDENNE, Prof. Ir. A., ASTRON, Oude Hogeveensedijk 4, Postbus 2, NL-7990 AA DWINGELOO, NETHERLANDS, Tel. +31 521 595 134, Fax +31 521 595 101, E-mail Ardenne@astron.nl, brink@astron.nl (109)
- VAN BLADEL, Prof. J., G. De Smetlaan 22, B-9831 DEURLE, BELGIUM, Tel. +32 9-282 4488, Fax +32 9-264 4288, E-mail hvanblad@skynet.be (104)
- VAN DAELE, Prof. DR. P., Dept. of Information Technology (INTEC), IBBT - Ghent University, Gaston Crommenlaan 8 bus 201, B-9050 GENT, BELGIUM, Tel. +32 9 331 49 06, Fax +32 9 331 48 99, E-mail peter.vandaele@intec.Ugent.be (104, 106)
- VAN DEN BOGAART, Ir. F.L.M., TNO Defence, Security and Safety, Postbus 96864, 2509 JG 'S-GRAVENHAGE, NETHERLANDS, Tel. +31 70 374 0042, Fax +31 70 374 0653, E-mail frank.vandenbogaart@tno.nl (106)
- VAN DEURSEN, Prof. A.P.J., Faculteit Electrotechniek, Technische Universiteit Eindhoven, PO Box 513, NL-5600 MB EINDHOVEN, NETHERLANDS, Tel. +31 40 247 4434/3993, Fax +31 40 245 0735, E-mail A.P.J.v.Deursen@tue.nl (104, 107)
- VAN DRIEL, Dr. W., GEPI, Observatoire de Paris, 5, Place Jules Janssen, F-92195 MEUDON CEDEX, FRANCE, Tel. +33 1 4507 7731, Fax +33 1 4507 7709, E-mail wim.vandriel@obsppm.fr (111, 113)

- VAN LIL, Prof. E., DIV. ESAT-TELEMIC, K.U. Leuven, Kasteelpark Arenberg 10, Bus 2444, B-3001 HEVERLEE, BELGIUM, Tel. +32 16 32 1113, Fax +32 16 32 1986, E-mail Emmanuel.VanLil@ESAT.KULeuven.Be (105)
- VANDEBOSCH, Prof. G.A.E., DIV. ESAT-TELEMIC, Katholieke Universiteit Leuven, Kasteelpark Arenberg 10, Bus 2444, B-3001 LEUVEN, BELGIUM, Tel. +32 16 32 11 10, Fax +32 16 32 19 86, E-mail Guy.Vandenbosch@ESAT.KULeuven.Be (107)
- VANDENDORPE, Prof. L., UCL, TELE, Batiment Stévin, Place du Levant, 2, B-1348 LOUVAIN-LA-NEUVE, BELGIUM, Tel. + 32 10-47 23 12, Fax + 32 10-47 20 89, E-mail Vandendorpe@tele.ucl.ac.be (106)
- VARJU, Dr. G., Department of Electric Power Engineering, Budapest University of Technology and Economics, Egrý J. u., H-1111 BUDAPEST, HUNGARY, Tel. +36 1 463 3016, Fax +36 1 463 3600, E-mail varju.gyorgy@vet.bme.hu (107)
- VAUGHAN, Prof. R., Engineering Science, Simon Fraser University, 8888 University Drive, Burnaby, BC V5A 1S6, CANADA, Tel. +1-7787826889, Fax +001 604 291 4951, E-mail rvaughan@sfu.ca, rodney_vaughan@sfu.ca (105)
- VELASQUEZ-LOPEZ, Dr. C. V., Director General de la Secretaria de Comunicaciones, Ministerio de Transportes y Comunicaciones, Jiron Zorritos N° 1203, LIMA, PERU, Tel. +51 1 615 7800, E-mail cavaldez@mtc.gob.pe (107)
- VELINOV, Prof. P., Institute for Space and Solar Terrestrial Research, Bulgarian Academy of Sciences, 6 Moskovska Str., 1000 SOFIA, BULGARIA, Tel. +359 2 979 3434, E-mail pvelinov@bas.bg (109)
- VENA, Assoc. Prof. A., IES (UMR n°5214 CNRS-UM2), Université de Montpellier 2, 860 rue Saint Priest, 34000 Montpellier, FRANCE, Tel. + 33 4 671 44629, E-mail arnaud.vena@univ-montp2.fr (106)
- VERGERES, Mr. D., Chef de section, OFCOM, Rue de l'Avenir 44, 2501 BIENNE, SWITZERLAND, Tel. +41 32 327 57 20, Fax +41 32 327 57 77, E-mail daniel.vergeres@bakom.admin.ch (107)
- VESZELY, Dr. Gy., Department of Broadband Infocommunication Systems, BME - Budapest University of Technology and Economics, H-1521 BUDAPEST, HUNGARY, Tel. +36 1-463-3188, Fax +36 1-463-3189, E-mail Veszely@evt.bme.hu (105)
- VEYRET, Dr. B., Laboratoire PIOMCNRS/EPHE, Université de Bordeaux 1, ENSCPB, 16, Av. Pey Berland, F-33607 PESSAC CEDEX, FRANCE, Tel. +33 5 40 00 66 29, Fax +33 5 40 00 66 29, E-mail b.veyret@icnirp.org (113)
- VILCAHUAMAN CAJACURI, Prof. L., Seccion Electricidad y Electricidad, Pontificia Universidad Católica del Perú, Av. Universitaria 1800, San Miguel, LIMA 32, PERU, Tel. +51 1 6262000 (ext. 5030), E-mail lvilcah@pucp.edu.pe (109)
- VILJANEN, Dr. A., Finnish Meteorological Institute, Arctic Research, P.O. Box 503, 00101 HELSINKI, FINLAND, Tel. +358 9 1929 4668, Fax +358 9 1929 4603, E-mail Ari.Viljanen@fmi.fi (107,110)
- VOLAKIS, Prof. J.L., Electroscience Lab, The Ohio State University, 1320 Kinnear Rd., Columbus, OH 43212, USA, Tel. +1 614-292-5846, Fax +1 614 292 7297, E-mail volakis@ece.osu.edu, volakis.1@osu.edu (105)
- VOMVORIDIS, Prof. I., School of Electrical & Computer Eng., National Technical University of Athens, Iroon Polytechniou 9, GR-15773 ATHENS, GREECE, Tel. +30 210 7723684, Fax +30 210 7723513, E-mail vomvor@central.ntua.gr (108)
- VRBA, Prof. J., Em Field (k13117), Czech Technical University In Prague, Technicka 2, 16627 Prague, Czech Republic, Tel. +420 224 352 298, Fax +420 233 339 958, E-mail vrba@fel.cvut.cz (109)
- W**ADA, Prof. O., Department of Electrical Engineering, Graduate School of Engineering, Kyoto University, Kyoto Daigaku Katsura, Nishikyo-ku, Kyoto 615-8510, JAPAN, Tel. +81 75 383 2244, Fax +81 75 383 2245, E-mail wada@kuee.kyoto-u.ac.jp (107)
- WALDE, Mr. C.-H., , Nordic Radio Society, Tornvägen 7, SE-183 52 TÄBY, SWEDEN, Tel. +46 8 756 61 60, E-mail info@walde.se (112)
- WALLEN, Dr. H., Dept. Radio Science and Engineering, Aalto University, P.O. Box 13000, Otakaari 5 A, FI-00076 AALTO, FINLAND, Tel. +358 9 470 25668, E-mail henrik.wallén@aalto.fi (112)
- WARNANT, Mr. R., Department of Geography, Geomatics - Geodesy and GNSS, Bâtiment B5a, Allée du 6 août 17, B-4000 LIEGE, BELGIUM, Tel. +32 4 366 90 16, Fax +32 4 366 56 93, E-mail Rene.Warnant@ulg.ac.be (108)
- WARRINGTON, Prof. M., Department of Engineering, University of Leicester, 3 Long Meadow, Leicester, Leics LE1 7RH, United Kingdom, Tel. +44 116 252 2561, Fax +44 116 252 2619, E-mail emw@le.ac.uk (112)
- WATANABE, Dr. S., Department of Cosmosciences, Hokkaido University, , Sapporo 060-0810, JAPAN, Tel. +81 11 706 2757, Fax +81 11 706 2760, E-mail shw@ep.sci.hokudai.ac.jp (111)
- WATERS, Assoc. Prof. C., Centre for Space Physics, School of Mathematical and Physical Sciences, University of Newcastle, University Drive, CALLAGHAN NSW 2308, AUSTRALIA, Tel. +61 2 4921 6907, Fax +61 2 4921 5421, E-mail colin.waters@newcastle.edu.au (108)
- WEISS, Dr. S.J., Antennas and RF Technology Integration Branch, Army Research Laboratory, 2800 Powder Mill Road, Adelphi, MD 20783-1198, USA, Tel. +1 301 394 1987, Fax +1 301 394 5132, E-mail steven.j.weiss14.civ@mail.mil (105)
- WEN, Professor, Emc Lab., Beijing Jiaotong University, 100044 Beijing, China, Tel. 86-10-51688096x808, E-mail yinghongwen@vip.sina.com (107)
- WIART, Dr. J., Orange Labs, DMR/RMC, 38-40, rue du Général Leclerc, F-92131 ISSY LES MOULINEAUX CEDEX, FRANCE, Tel. +33 1 45 29 58 44, E-mail joe.wiart@orange-ftgroup.com, joe.wiart@orange.com (109, 110)
- WICHMAN, Prof. R., Dept. of Signal Processing and Acoustics, Aalto University, PO Box 13000, FI-00076 AALTO, FINLAND, Tel. +358 9 470 22484, E-mail Risto.Wichman@aalto.fi (106)

WIELEBINSKI, Prof R., Max Plank Institute for Radioastronomy, Auf dem hügel 69, 53121 Bonn, Germany, Tel. +49 228525300, Fax +49 228525436, E-mail rwielebinski@mpifr-bonn.mpg.de, wielebinski36@t-online.de (111)

WIJNHOLDS, Dr. S., R&D, ASTRON, Oude Hoogeveensedijk 4, 7991 PD Dwingeloo, Netherlands, Tel. +31 521 595100, Fax +31 521 595101, E-mail wijnholds@astron.nl, breman@astron.nl (109,110,113)

WIKLUNDH, Dr. K., FOI, Swedish Defence Research Agency, P. O. Box 1165, 58111 Linköping, Sweden, Tel. +46 13 37 80 55, Fax +46 13 37 81 00, E-mail kia.wiklundh@foi.se (107)

WILFERT, Prof. O., Brno University of Technology, Purkynova 118, BRNO 612 00, CZECH REPUBLIC, Tel. +420 541 149 130, Fax +420 541 149 224, E-mail wilfert@feec.vutbr.cz (106)

WILKINSON, Dr. Phil, IPS, Bureau of Meteorology, P.O. Box 1386, Haymarket, NSW 1240, AUSTRALIA, Tel. +61 2-9213 8003, Fax +61 2-9213 8060, E-mail phil_wilkinson@internode.on.net, p.wilkinson@bom.gov.au (104, 108, 110, 113)

WILSON, Mrs. C., Propagation and Spectrum Wireless Technologies Lab., CSIRO ICT Centre, P.O. Box 76, EPPING, NSW1710, AUSTRALIA, Tel. +61293724264, Fax +61293724490, E-mail carol.wilson@csiro.au (107)

WITCZAK, Dr. A., Institute of Radioelectronics, Military University of Technology, Ul. Kaliskiego 2, 00-908 WARSAW, POLAND, Tel. +48 22 683 96 46, Fax +48 22 683 74 61, E-mail andrzej.witczak@wat.edu.pl, awitczak@wat.edu.pl (112)

WU, Dr. J., Director General CETC, No 27 Wanshoulou, 100846 BEIJING, CHINA (CIE), Tel. +86 10 68207371, Fax +86 10 68218354, E-mail jian.wu@263.net (104,112)

WU, Mr. T., China Academy of Telecommunication Research, Ministry of Industry and Information Technology, No.52 Huayuanbei road, 100191 Beijing, CHINA, E-mail wutongning@emcite.com (110)

YAGITANI, Prof. S., Faculty of Electrical and Computer Engineering, Institute of Science & Engineering, Kanazawa University, Kakuma-machi, Kanazawa 920-1192, Japan, Tel. +81-76-234-4858, Fax +81-76-234-4859, E-mail yagitani@is.t.kanazawa-u.ac.jp (112)

YAMAMOTO, Dr M., Research Institute for Sustainable Humanosphere, Kyoto University, Gokasho, Uji, Kyoto 611-0011, Japan, Tel. +81 774 38 3814, Fax +81 774 31 8463, E-mail yamamoto@rish.kyoto-u.ac.jp (108)

YAMPOLSKY, Prof. Yu. M., Institute of Radioastronomy, NASU, ul. Krasnoznamenaya 4, KHARKOV 310002, UKRAINE, Tel. +380 572-44-8579, Fax +380 572-44-6506, E-mail yampol@rian.kharkov.ua (108)

YAN, Dr. Y., Key Laboratory Of Solar Activity, National Astronomical Observatories, A20 Datun Road, Chaoyang District, BEIJING 100012, CHINA (CIE), Tel. +86 10 6485 1674, Fax +86 10 6486 3314, E-mail yyh@nao.cas.cn (104, 109)

YARLEQUE MEDINA, Dr. M., Departamento de Ingenieria, Pontificia Universidad Católica del Perú, Sección Ingeniería de las Telecomunicaciones Av. Universitaria 1801, San Miguel, LIMA32, PERU, Tel. +51-1-626-2452, Fax +51-1-626-2116, E-mail myarleq@pucp.edu.pe (105)

YAROVOY, Prof. dr. A., Faculteit Elecktotechniek, Wiskunde en Informatica, Technische Universiteit Delft, Mekelweg 4, 2628 CD DELFT, NETHERLANDS, Tel. +31 15 278 2496, Fax +31 15 278 4046, E-mail a.yarovoy@ewi.tudelft.nl (105)

YOSHIDA, Mr. S., YOKOWO CO., LTD., 1112 KANOHARA, TOMIOKA, GUNMA, 370-2495, JAPAN, Tel. +81-274-62-7133, Fax +81-274-62-7133, E-mail mc@yokowo.co.jp (110)

ZAGHLOUL, Dr. A. I, Ece, Virginia Tech, 7121 Arrowood Rd, 20817 Bethesda, USA, Tel. +1-301-394-0886, E-mail amirz@vt.edu (106, 113)

ZAGORODNIY, Prof. A.G., Institute for Theoretical Physics, NASU, 14b, Metrologichna street, KIEV 03143, UKRAINE, Tel. +380 44 492 1423, Fax +380 44 526 5998, E-mail azagorodny@bitp.kiev.ua (108)

ZAIN-EL-DEEN, Prof. S., Faculty of Electronic Engineering, Menafia University, Menafia, EGYPT, E-mail ansaber@yahoo.com (108)

ZEDDAM, Dr. A., FT R&D, DTD/SFE, 2 avenue Pierre Marzin, BP 40, F-22307 LANNION CEDEX, FRANCE, Tel. +33 2-9605 3938, Fax +33 2-9605 3427, E-mail ahmed.zeddami@orange-ftgroup.com (110)

ZERROUKI, Dr. C., Conservatoire National des Arts et Métiers, 97 Rue de Reuilly, FRANCE, E-mail zerrouki@cnam.fr (105)

ZHAO, Dr. H., Electronics and Photonics, Institute of High Performance Computing, #16-16 Connexis, 1 Fusionopolis Way, Singapore 138632, SINGAPORE, Tel. +65 93754810, Fax +65 64674350, E-mail zhaoh@ihpc.a-star.edu.sg (105)

ZHAO, Prof. Z., School Of Electronic Information, Wuhan University, 129 Luoyu Road, Wuhan, Hubei, China, Wuhan, China, Tel. 86-27-68756343, Fax 86-27-68756343, E-mail dicilab@yahoo.com.cn (108)

ZHELYAZKOV, Prof. I., Faculty of Physics, Sofia University, 5 James Boucher Blvd., BG-1164 SOFIA, BULGARIA, Tel. +35928161641, E-mail izh@phys.uni-sofia.bg (108)

ZHOGUN, Dr. V.N., VNIIFTRI, Mendeleev, Moscow Region, 141570, RUSSIA, Tel. +7 495 744 81 21, Fax +7 499 720 9334, E-mail zhogun@vniiftri.ru (105)

ZINCHENKO, Dr. Igor, Radio Engineering And Millimeter Wave Astronomy, Institute Of Applied Physics Of The Russian Academy Of Sciences, 46 Ulyanov Str., 603950 Nizhny Novgorod, Russia, Tel. +7 831 4367253, E-mail zin@appl.sci-nnov.ru (109)

ZOMBORY, Prof. L., Department of Broadband Infocommunication Systems, BME - Budapest University of Technology and Economics, Goldmann Gy. tér 3., H-1111 BUDAPEST, HUNGARY, Tel. +36 1-463-1559/1824, Fax +36 1-463-3289, E-mail zombory@mht.bme.hu (112)

ZOZULYA, Prof. Yu.O., Academy of Medical Sciences of Ukraine, Inst. of Neurosurgery, Acad. A. Romodanov, 32, Manuilsky st., KIEV 04050, UKRAINE, Tel. +380 44-213 9573, Fax +380 44-213 9573, E-mail brain@neuro.kiev.ua (109)

ZVANOVEC, Assoc. Prof. S., Faculty of Electrical Engineering, Czech Technical university, Technicka 2, Prague 6 16627, Czech Republic, Tel. +420 224 355 966, Fax +420 233 339 958, E-mail xzvanove@fel.cvut.cz (107)

ZWAMBORN, Prof. dr. ir A.P.M., TNO Defence, Security and Safety, Postbus 96864, 2509 JG 'S-GRAVENHAGE, NETHERLANDS, Tel. +31 70 374 0033, Fax +31 70 374 0653, E-mail Peter.Zwamborn@tno.nl (109)

Information for Authors

Content

The *Radio Science Bulletin* is published four times per year by the Radio Science Press on behalf of URSI, the International Union of Radio Science. The content of the *Bulletin* falls into three categories: peer-reviewed scientific papers, correspondence items (short technical notes, letters to the editor, reports on meetings, and reviews), and general and administrative information issued by the URSI Secretariat. Scientific papers may be invited (such as papers in the *Reviews of Radio Science* series, from the Commissions of URSI) or contributed. Papers may include original contributions, but should preferably also be of a sufficiently tutorial or review nature to be of interest to a wide range of radio scientists. The *Radio Science Bulletin* is indexed and abstracted by INSPEC.

Scientific papers are subjected to peer review. The content should be original and should not duplicate information or material that has been previously published (if use is made of previously published material, this must be identified to the Editor at the time of submission). Submission of a manuscript constitutes an implicit statement by the author(s) that it has not been submitted, accepted for publication, published, or copyrighted elsewhere, unless stated differently by the author(s) at time of submission. Accepted material will not be returned unless requested by the author(s) at time of submission.

Submissions

Material submitted for publication in the scientific section of the *Bulletin* should be addressed to the Editor, whereas administrative material is handled directly with the Secretariat. Submission in electronic format according to the instructions below is preferred. There are typically no page charges for contributions following the guidelines. No free reprints are provided.

Style and Format

There are no set limits on the length of papers, but they typically range from three to 15 published pages including figures. The official languages of URSI are French and English: contributions in either language are acceptable. No specific style for the manuscript is required as the final layout of the material is done by the URSI Secretariat. Manuscripts should generally be prepared in one column for printing on one side of the paper, with as little use of automatic formatting features of word processors as possible. A complete style guide for the *Reviews of Radio Science* can be downloaded from <http://www.ips.gov.au/IPSHosted/NCRS/reviews/>. The style instructions in this can be followed for all other *Bulletin* contributions, as well. The name, affiliation, address, telephone and fax numbers, and e-mail address for all authors must be included with

All papers accepted for publication are subject to editing to provide uniformity of style and clarity of language. The publication schedule does not usually permit providing galleys to the author.

Figure captions should be on a separate page in proper style; see the above guide or any issue for examples. All lettering on figures must be of sufficient size to be at least 9 pt in size after reduction to column width. Each illustration should be identified on the back or at the bottom of the sheet with the figure number and name of author(s). If possible, the figures should also be provided in electronic format. TIF is preferred, although other formats are possible as well: please contact the Editor. Electronic versions of figures *must* be of sufficient resolution to permit good quality in print. As a rough guideline, when sized to column width, line art should have a minimum resolution of 300 dpi; color photographs should have a minimum resolution of 150 dpi with a color depth of 24 bits. 72 dpi images intended for the Web are generally *not* acceptable. Contact the Editor for further information.

Electronic Submission

A version of Microsoft *Word* is the preferred format for submissions. Submissions in versions of T_EX can be accepted in some circumstances: please contact the Editor before submitting. *A paper copy of all electronic submissions must be mailed to the Editor, including originals of all figures.* Please do *not* include figures in the same file as the text of a contribution. Electronic files can be sent to the Editor in three ways: (1) By sending a floppy diskette or CD-R; (2) By attachment to an e-mail message to the Editor (the maximum size for attachments *after* MIME encoding is about 7 MB); (3) By e-mailing the Editor instructions for downloading the material from an ftp site.

Review Process

The review process usually requires about three months. Authors may be asked to modify the manuscript if it is not accepted in its original form. The elapsed time between receipt of a manuscript and publication is usually less than twelve months.

Copyright

Submission of a contribution to the *Radio Science Bulletin* will be interpreted as assignment and release of copyright and any and all other rights to the Radio Science Press, acting as agent and trustee for URSI. Submission for publication implicitly indicates the author(s) agreement with such assignment, and certification that publication will not violate any other copyrights or other rights associated with the submitted material.

Application for an URSI Radioscientist



APPLICATION FOR URSI RADIOSCIENTIST

I have not attended the last URSI General Assembly & Scientific Symposium, and wish to remain/become an URSI Radioscientist in the 2014-2017 triennium. This application includes a subscription to *The Radio Science Bulletin* and inclusion in the URSI mailing lists.

(Please type or print in **BLOCK LETTERS**)

Name : Prof./Dr./Mr./Mrs./Ms. _____
Family Name First Name Middle Initials

Present job title: _____

Years of professional experience: _____

Professional affiliation: _____

I request that all information be sent to my home business address, i.e.:

Company name: _____

Department: _____

Street address: _____

City and postal/zip code: _____

Province/State: _____ Country: _____

Tel: _____ ext. _____ Fax: _____

E-mail: _____

Areas of interest (Please tick)

- | | | | |
|----------------------------|---|----------------------------|--|
| <input type="checkbox"/> A | Electromagnetic Metrology | <input type="checkbox"/> F | Wave Propagation & Remote Sensing |
| <input type="checkbox"/> B | Fields and Waves | <input type="checkbox"/> G | Ionospheric Radio and Propagation |
| <input type="checkbox"/> C | Radio-Communication Systems & Signal Processing | <input type="checkbox"/> H | Waves in Plasmas |
| <input type="checkbox"/> D | Electronics and Photonics | <input type="checkbox"/> J | Radio Astronomy |
| <input type="checkbox"/> E | Electromagnetic Environment & Interference | <input type="checkbox"/> K | Electromagnetics in Biology & Medicine |

<input type="checkbox"/>	By signing up, you agree to be included into the URSI mailing list. You can unsubscribe at any time.
<input type="checkbox"/>	I agree that my contact details will be used by URSI only and will never be transferred to other parties.

Please return this signed form to :

The URSI Secretariat
c/o Ghent University / INTEC
Sint-Pietersnieuwstraat 41
B-9000 GHENT, BELGIUM
E-mail: info@ursi.org