

# The Radio Science Bulletin

ISSN 1024-4530

INTERNATIONAL  
UNION OF  
RADIO SCIENCE

UNION  
RADIO-SCIENTIFIQUE  
INTERNATIONALE



No 288  
March 1999

Publié avec l'aide financière de l'ICSU

URSI, c/o University of Gent (INTEC)  
St.-Pietersnieuwstraat 41, B-9000 Gent (Belgium)

# Contents

<b>Editorial .....</b>	<b>3</b>
<b>Letter to the Editor .....</b>	<b>3</b>
<b>URSI Homepage .....</b>	<b>4</b>
<b>In Memoriam .....</b>	<b>5</b>
<b>Abu Simbel Radio Telescope Project in the Upper Egypt.....</b>	<b>8</b>
<b>The Mir Space Station Ionospheric Sounder .....</b>	<b>14</b>
<b>Summary Report of the Strategy Meeting .....</b>	<b>18</b>
<b>Toronto General Assembly.....</b>	<b>20</b>
The current status of the Scientific Programme	
<b>Conferences .....</b>	<b>21</b>
<b>News from the URSI Community .....</b>	<b>36</b>
Memories of Jim Wait; an URSI General Assembly through the eyes of a Young Scientist; News from the Committees in Germany, Israel and Korea; and an Award presented to an URSI Colleague	
<b>UTC Time Step .....</b>	<b>45</b>
<b>URSI Publications.....</b>	<b>47</b>
<b>Information for authors .....</b>	<b>49</b>

**EDITOR-IN-CHIEF**  
URSI Secretary General  
Paul Lagasse  
Dept. of Information Technology  
University of Gent  
St. Pietersnieuwstraat 41  
B-9000 Gent  
Belgium  
Tel. : (32) 9-264 33 20  
Fax : (32) 9-264 42 88  
E-mail : rsb@intec.rug.ac.be

#### EDITORIAL ADVISORY BOARD

Thomas B.A. Senior  
(URSI President)  
Peter J.B. Clarricoats  
W. Ross Stone

#### PRODUCTION EDITOR

Inge Heleu

**EDITOR**  
Piotr Sobieski  
Telecommunications and Remote Sensing  
Université Catholique de Louvain  
Bâtiment Stévin  
Place du Levant 2  
B-1348 Louvain-la-Neuve  
Belgium  
Tel. : (32) 10-47 23 03  
Fax : (32) 10-47 20 89  
E-mail : sobieski@tele.ucl.ac.be

#### ASSOCIATE EDITORS

J.M. Arnold (Com. B)	R.D. Hunsucker
J.P.V.P. Baptista (Com. F)	D.L. Jones (Com. E)
P. Bernardi (Com. K)	Y. Karasawa (Com. F)
P. Bernhardt (Com. H)	B.S. Mathur (Com. A)
S. Dvorak	Z.B. Popovic (Com. D)
C. Haldoupis (Com. G)	A. Sihvola

W.R. Stone
G. Tartara (Com. C)
R. Treumann
P. Van Daele
L. Vandendorpe
J.H. Whitteker

#### *For information, please contact :*

The URSI Secretariat  
c/o University of Gent (INTEC)  
Sint-Pietersnieuwstraat 41  
B-9000 Gent, Belgium  
Tel. : (32) 9-264 33 20  
Fax : (32) 9-264 42 88  
E-mail : inge.heleu@intec.rug.ac.be  
<http://www.intec.rug.ac.be/ursi>

The International Union of Radio Science (URSI) is a foundation Union (1919) of the International Council of Scientific Unions as direct and immediate successor of the Commission Internationale de Télégraphie Sans Fil which dates from 1913.

Unless marked otherwise, all material in this issue is under copyright © 1998 by Radio Science Press, Belgium, acting as agent and trustee for the International Union of Radio Science (URSI). All rights reserved. Radio science researchers and instructors are permitted to copy, for non-commercial use without fee and with credit to the source, material covered by such (URSI) copyright. Permission to use author-copyrighted material must be obtained from the authors concerned.

The articles published in the Radio Science Bulletin reflect the authors' opinions and are published as presented. Their inclusion in this publication does not necessarily constitute endorsement by the publisher.

Neither URSI, nor Radio Science Press, nor its contributors accept liability for errors or consequential damages.



# Editorial

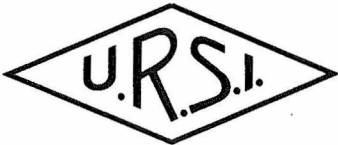

Dear URSI Correspondent,

Welcome to our March issue of the Radio Science Bulletin. You will find in this number two interesting descriptive contributions. One of these is by N. Danilkin who presents a radio-sounder located on the MIR Station orbiting around the Earth. This instrument is open to international co-operation for real-time ionospheric information production. The other one, by M. Shaltout, describes a radio telescope project to be located near the famous Egyptian site of Abu Simbel, and which purpose is to fill a coverage gap and make available a continuous VLBI network expanding from Western Europe to South Africa.

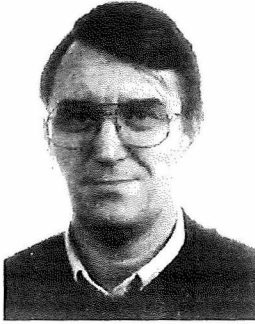

Beside this scientific part you will find in memoriam addresses about two of our colleagues Voge and Wait.

I also received a letter from C. Egidi underlining

some historical aspects of the contributions of T. Calzecchi-Onesti in the field of radio telegraphy around the turn of the twentieth century. I submit it to your thoughts.

Less than six months ahead we have our General Assembly in Toronto. I am sure most of you already planned this in your schedule and visited the URSI web site that offers essential information about this important event. Hereafter you will also find the current status of our scientific programme.

The administrative part of our Bulletin contains the usual announcements, calendar and reports about the scientific activities sponsored or supported by URSI as well as some news from three member committees and colleagues around the world.

I wish you a pleasant reading.

Piotr Sobieski, Editor

# Letter to the Editor

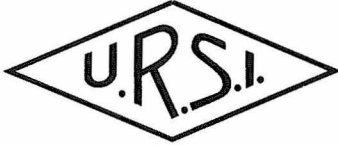

## The early times of radio telegraphy : Temistocle Calzecchi-Onesti, a pioneer

Claudio Egidi

Prof. Emeritus of the Politecnico di Torino, Torino, Italy

The first news on this pioneer were given to me, as to my school fellows, through the tablet at the entrance of the classic "Gymnasium - Liceo Annibal Caro" of Fermo, an old town in middle (Region "Marche") Italy where I was educated from 1924-25 to 1931-32. However personally I resumed later a specific study on this scientist, through many documents forwarded to me by my dear friend Prof. Giovanni Monelli and by the Direction of the Town library of Fermo, formerly directed by Can. Prof. G. Cicconi.

While I hope to publish later a more detailed paper on this subject, I have considered profitable to cast a glance on some events of the last part of the XIX century, that saw the publication of the famous English patent N.12039, applied by Marconi in 1896 with the title "Improvements in Transmitting Electrical Impulses and Signals and in Apparatus therefore".

Line 24 and 25 of the patent sound as follows "The appliance I employ consists of a tube containing conductive powder, or grains, or conductors in imperfect contact..." and this is the general description of the "metallic powder detector" used at that time.

The detector, a delicate and critical part of the receiver, was effectively studied and experimented by Calzecchi-Onesti in 1884-85, changing the metal grains, their dimensions and other parameters and analysing their resistance under electric and mechanical actions.

T.C.T.O. was born in the small village of Lapedona on December 13, 1853. His family then moved to Monterubbiano. Both villages belong to the Fermo district. Later Temistocle moved to Ascoli Piceno, where he got the diploma of elementary school teacher. Later he went to the Pisa University, where he had masters as Dini and Felici.

He took his graduation in 1878, was nominated physics professor in 1879 in the Technical Institut of L'Aquila; in 1883 he was transferred to the above mentioned Liceo Annibal Caro of Fermo. There he experimented the metallic filings and invented the small component that later Lodge will call "coherer".

He then founded a Meteorological Observatory and he established a regular service over the entire Fermo district. He carried out research of the microseismical type.

Very modest he was surprised to know that Marconi has used his detector.

In 1898 the International Electricity Exhibition assigned to him the gold medal for his researches on the metallic filings.

In 1898, he begins his lessons at the Liceo "C. Beccaria" of Milan; in 1914 he moves to Rome, in order to teach at the Liceo Umberto I. In 1920 (40<sup>th</sup> and last year of teaching) he comes back to Monterubbiano where he passes away on 23 November 1922.

Around 1887 he was distracted from his physical activity by another scientific field concerning two deaf-and-dumb little girls, with whom he obtained noticeable results in co-operation also with a laboratory in Vienna. However this activity distracted him from physics, just in the years of major success for the radiocommunications.

In the Review Nuovo Cimento, 3<sup>rd</sup> Series, vol. XVI, 1884, p. 58-64 he published his results obtained on a small tube containing copper filing with various packaging densities and measuring the resistance change produced by several subsequent interruptions. Another paper was published in January-February 1885 on the same review at pages 38-42 and a third one later with applications to

microseismics. Prof. Suerbach of the Breslau University published some critical remarks in the Wiedemann's Annals on 1886 : Calzecchi publishes the translation of the note into Italian and answers to the criticism.

What did happen before? Prof. S. Munck of Rosenshold of the Lund University had published in the review Annalen der Physik, 1835, p. 437 an important paper on this subject, but it did receive little attention, probably because the time was not ripe. Really, nearly 50 years had elapsed when Calzecchi-Onesti published his first contribution : it is rightful to speak of a true rediscovery by him of the metallic filings properties.

And afterwards? In 1890 the French researcher Edouard Branly publishes a paper "Variations de conductibilité sous diverses influences électriques". "C.R.", III, 785-787. He does not quote any previous paper on this subject, not even when a polemic is open : he completely ignores Calzecchi-Onesti contributions.

Some explanations have been attempted, one of which is the possible scarce esteem given by a researcher operating in a great city as Paris to a medium-school professor operating in a minor town of Italy.

Because there are some fixed dates in which Branly was informed about the work of C.-O. and nevertheless he did not deign to quote him, I venture a guess.

Branly, thanks to his undoubted merits, had great ambitions and hoped to share with Marconi the glory of the Nobel Prize, so that any other "minor detail" such as the structure of the detector could be disregarded by him.

However the polemic continued a long time through a relation of him, who defended and supported him strongly.

**URSI Homepage**

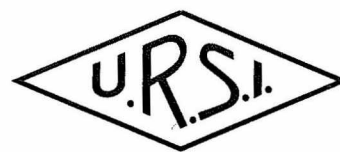

Please visit our Homepage from time to time at :

**<http://www.intec.rug.ac.be/ursi/>**

Latest changes and links :

- Dates of Business meetings during Toronto General Assembly
- Links to recently established sites of URSI Member Committees
- Links to updated Commission sites
- Full and summary reports of Strategy meeting
- The URSI Conference Calendar (regularly updated, with links to the conference sites)

Please also visit the site of the Toronto General Assembly, via the URSI Homepage or direct at :

**<http://www.nrc.ca/confserv/ursi99/welcome.html>**

## JEAN VOGÉ 1921-1998

Jean Vogé passed away in Paris on 25 May 1998. Born on 21 February 1921 in Casablanca (Morocco), he was not only a distinguished radio scientist, but also an inspired and open-minded thinker and organiser in our « information society ».

Graduated from Ecole Polytechnique and from Ecole Nationale Supérieure des Télécommunications, he joined in 1944 the newly created Centre National d'Etudes des Télécommunications (CNET), where he started research studies on the propagation of microwaves in the troposphere.

In the 1950's, on his instigation, the CNET secured substantial means for both theoretical and experimental work. The efforts there developed had to lead to a research programme of wide extent in the fields of radio wave propagation phenomena. The brilliant results soon afterwards achieved established the high repute of CNET, which was regarded world wide as a centre of excellence.

In 1954, Jean Vogé was temporarily attached to the International Radio Consultative Committee (CCIR) and from 1964 to 1969 he became the representative of France in INTELSAT. From 1968 to 1977, he discharged the functions of Director and President of the Council of the Ecole Nationale Supérieure des Télécommunications. During his particularly rich and fruitful career, Jean Vogé was invited to lecture in numerous schools and universities. In 1968, the title of *éméritus* professor was conferred upon him by the Université Libre de Bruxelles.

Jean Vogé took also a major part in the creation of the Institut de l'Audiovisuel et des Télécommunications in Europe (IDATE), and became its first President (1977-1988). Among his numerous written works on our modern « information society », we quote the last one published in 1997: « *Le complexe de Babel, crise ou maîtrise de l'information / The Babel complex crisis or mastery of information* ».

The list of the various offices held by Jean Vogé within URSI is quite impressive and is the best illustration of his deep involvement and of the leading part he played in the affairs of the Union. His name is already to be found in the Proceedings of the General Assembly held in 1952 in Sydney, where he acted as Reporter both in the Commission on Radio and Troposphere. From 1954 to 1957, he was Secretary of the latter, and its Chairman from 1960 to 1966.

In 1969, he was elected Vice-President of the Union and, until 1975 he acted at the same time as Treasurer, a most delicate mission indeed in that economically difficult period.

As president of URSI from 1975 to 1978, he played a key role in the implementation of the major decisions made at the Lima Assembly, following the period of intensive discussions on the redefinition of URSI's objects.

He was a member of the Committee on the reorganisation of URSI (1963-1966), Chairman of the URSI Committee on Space Research (1969-1975), Representative of the Union on the Executive Council of COSPAR (1969-1975) on ICSU (1975-1978) and on the ICSU Committee for the Teaching of Science. He had been also a member of the URSI Committee on

International Co-operation in Geophysics, of the Inter-Union Commission on Radio Meteorology, of the IUCG Committee on Atmospheric Sciences, of the URSI Committee on CCIR Work and, from 1981 to 1996, of the URSI Committee on Developing Countries. As Chairman of the Programme Committee for the 60<sup>th</sup> URSI Anniversary Colloquium held in Brussels in 1979, he was instrumental in arranging for the participation of eminent personalities, among them three Nobel Prize Winners who delivered talks not only on the results of fundamental research, but also on the history of URSI and on the role of highly sophisticated systems for communication of information of many different kinds, which had become essential in modern society.

In the long-continuing debate, which took place in the period 1963-1975 regarding the future of URSI, Jean Vogé's forward-looking positions proved to be of primary importance. Together with Prof. Henry Booker, he was the author of a series of comprehensive proposals and recommendations, which were discussed at the 1972 Warsaw Assembly in the Council and in an open meeting with the participation of all delegates. Some of these recommendations have still a strong impact on URSI activities.

Mr Vogé felt that URSI should in future regard the study of information and communication science as the main basis of its activities, and that it should deal not only with radio waves but, by analogy, with acoustic and optical waves and their use in telecommunications and remote sensing. If URSI was to cover telecommunications science comprehensively, it should cover also the devices used in

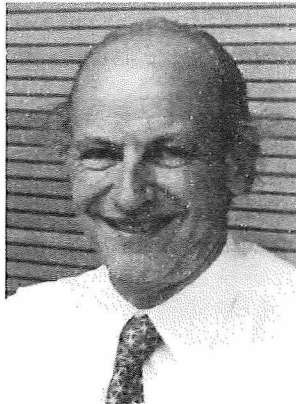

telecommunications. The achievement of that objective appeared to depend less on URSI at the International level than on URSI organisation at the national level, and Member Committees should be invited to mobilise all the interest that exists in their respective countries in all aspects of telecommunications science, and to project this interest onto the international scene at open symposia organised by URSI at or between General Assemblies. Also the Union should establish closer relations with the national engineering societies world-wide and act as the recognised international forum in the field.

On the other hand, URSI should retain an interest only in those branches of external geophysics that were likely to lead to further progress in understanding electromagnetic wave propagation, and in branches of research where the radio scientists as such could make a major contribution. Mr Voge proposed that URSI Commissions should place more emphasis on the propagation of waves through the various media, i.e.: interstellar medium (radio astronomy), ionised media (ionosphere and magnetosphere), non-ionised media (troposphere and solid Earth) and biological media (tissue, nerves, etc). Indeed he was the first in 1972 to suggest officially that URSI should concern itself with the interaction of electromagnetic fields with biological systems – a proposal which led ultimately to the creation of URSI Commission K on Electromagnetic in Biology and Medicine.

Another point, which Mr Voge felt was essential for the future, was the maintenance of a close co-operation with those Unions of ICSU the interests of which are overlapping with those of URSI in order to avoid duplication of effort.

Last but not least, URSI should reinforce its collaboration with ITU. On the one hand, it should promote the organisation of common open symposia, which would help identify the problems interfacing between research and applications. On the other hand, it should create a Special Committee to deal with the teaching of electromagnetic and telecommunications, and with the general problem of relations with Universities.

Jean Voge was not only a brilliant scientist, but also a man with clearness of vision and large powers of initiative. Indeed his interests did not confine to his special field of research, but extended to the more general problems of the impact of the scientific development on society. Those who have had the privilege of attending meetings he chaired appreciated the way he conducted discussions with firmness and great courtesy and his ability at the end of a long debate, to summarise the main items in a few explicit sentences. An inspiring teacher, and a wonderful colleague and friend, he will be remembered with affection by the URSI family.

Jean Voge is survived by his wife Geneviève, his constant companion and a familiar figure in URSI meetings, and by his two sons.

French URSI Committee

## JAMES R. WAIT 1924-1998

James R. Wait, Regents Professor Emeritus, University of Arizona, died October 1, 1998, in Tucson, Arizona, USA. He was 74.

James R. Wait was born in Ottawa in 1924 and educated in schools in Rockcliffe, Ottawa (His father was Canada's first Air Vice Marshal, the top rank in the Royal Canadian Air Force). He left university in 1942 to enlist in the Canadian Army and by 1945 was in charge of a radar maintenance group in Kingston, Ontario.

Dr. Wait received the B.A.Sc. and M.A.Sc. degrees in engineering physics in 1948 and 1949, respectively, and the Ph.D. degree in electromagnetic theory in 1951, all from the University of Toronto, Ontario, Canada. From 1942-1945 he served as a radar technician in the Canadian Army.

Dr. Wait began his distinguished career with Newmont Exploration, Ltd. in 1948. His Ph.D. thesis was based in part on research in electromagnetic methods in geophysics carried out in Jerome, Arizona with Newmont.



In 1952, Dr. Wait returned to Canada where he became a Section Leader at the Defense Research Telecommunications Establishment in Ottawa, Canada. One of his papers written during this period concerned scattering from an ionized cylinder. The paper is now a Citation Classic.

In 1955, Dr. Wait joined the National Bureau of Standards in Boulder, Colorado and subsequently served as a Senior Scientist at the National Oceanic and Atmospheric Administration; Professor Adjoint in the Electrical Engineering Department at the University of Colorado; Consultant to the Institute for Telecommunications; and founding member and Fellow of the Cooperative Institute for Research in Environmental Sciences. This was widely felt to be the golden age of telecommunications, radio wave propagation, and remote sensing at the government laboratories in Boulder. Dr. Wait made fundamental contributions in all these areas during this period. In



addition, in 1975, Dr. Wait was instrumental in the creation of URSI's first sponsored journal *Radio Science*. He was the first editor, serving three successive terms. Jim Wait was series editor of the International Series of Monographs on Electromagnetic Waves published by Pergamon Press and subsequently the IEE Electromagnetic Waves Series.

As secretary of USNC/URSI in 1975-8 Jim Wait first suggested the joint US/Canada North American Radio Science Meetings held in Quebec 1980, Vancouver 1985, London 1991 and Montreal 1997.

In 1980, Jim Wait moved to Tucson, Arizona, where he became Professor of Electrical and Computer Engineering, with a joint appointment in Geosciences, at the University of Arizona. During this period, Dr. Wait was instrumental in the growth of the Electromagnetics Laboratory into a world-class facility. In addition to electromagnetic applications in geoscience, he was also very active in studies of lightning and atmospheric electricity. Some of his last papers were on the effects of "sprites" in the middle atmosphere, the electromagnetic fields produced by lightning, and the coupling of LEMP to power lines. In recognition of his superior research and teaching influence, he was appointed to the prestigious position of Regents Professor in 1988. In 1989, he retired from the University to become a private consultant, specializing in electromagnetic methods and their use in subsurface probing.

Dr. Wait was a pioneer in electromagnetic theory, with application to geophysical exploration. In particular, his writings on layered media and on induced polarization are well known and widely cited throughout the world. He was the author of eight books and over 800 publications in archival journals. He was a frequent speaker at universities, companies, and government laboratories throughout the world.

Dr. Wait has received numerous awards for his research in electromagnetics and electrical geophysics, including the IEEE Centennial Medal in 1984, the IEEE Geoscience and Remote Sensing Achievement Award in 1985, the IEEE Antennas and Propagation Distinguished Achievement Award in 1990, and the IEEE Heinrich Hertz Medal in 1992. He was elected to the National Academy of Engineering in 1977 and received the Balthasar van der Pol Gold Medal from URSI in 1978. In 1993, he was elected an honorary member of the Society of Exploration Geophysicists.

Jim Wait was an active member of the editorial advisory board of the *Radio Science Bulletin* and frequently contributed to the magazine. He served as an expert on the URSI Awards Panel and evaluated numerous nominees for URSI Awards. He often proposed candidates for the Senior Awards.

Dr. Wait's influence upon his colleagues and students is remarkable. Samples from the many tributes received, honoring his life and his influence are the following:

- "Jim was one of the nicest people that I have ever met. His demise is such a great loss to the engineering community and to humankind in general."
- "In spite of (the magnitude of) his contribution to EM science, he was a very modest man; a true scientist..."

- He was truly one of the greats of his (our) time, and one of the most prolific in substantive contributions. His consistent support and helping hand to those newly entering the field was also outstanding. Jim could be a tough critic, but he never bore down on a novice in a meeting, no matter how naive the presentation. I always admired that quality in him..."
- He was a tremendous resource for those of us involved in electromagnetic geophysics...Jim's work was revolutionary and laid the foundation for the development that occurred in mining geophysics...much of this kind of mineral exploration is based on the theoretical studies that Jim did in the 1950s. He did very important work and it still has a great deal of impact on people's lives."
- We were not close but he helped me unselfishly once and I've never forgotten his kindness."
- "...I will undoubtedly fall short of expressing how much Jim meant to me, how much of an influence he has had in my life and how I feel it is a privilege to, in some small way, carry on his legacy. I sincerely believe that our lives on earth continue in the lives of those we touch. I am very sorry I did not tell Jim this directly."
- "...as a young researcher,...I introduced myself to him...I was very impressed by his interest in a young, unknown, person, and his complete lack of pretentiousness."
- "I still remember how nice he was to me the first time I met him at the '73 Boulder meeting when I was still a grad student. I, of course, was in awe of him, just from his reputation, but he never treated me as anything but an equal. He sought me out and talked to me about the work I had presented. I still remember what a seemingly humble man he was...he didn't seem to feel that it was necessary to act like the superstar that he clearly was."
- "I first met him in the late 1950s when he was already recognized as a top expert in electromagnetics and radio wave propagation...He was a true scholar and gentleman. He cared about people and gave us immeasurable help and encouragement. We will miss this giant."
- "I was so sorry to hear of the death of Jim Wait. I have known Jim since my days in England in the mid-fifties, and it was he who encouraged me to come to the U.S. He was one of the first people I visited after I came here, and I will miss him as a friend and as a scientist whose knowledge and productivity always amazed me."

In addition to his scientific pursuits, Professor Wait was an avid hiker, biker, swimmer, and expert skier. He was also very interested in the history of radio science. In particular he was fascinated with the practical applications of electromagnetics attributable to Guglielmo Marconi, having visited Marconi's house near Bologna, Italy, and the sites of Marconi's experiments in the UK and Canada.

Surviving are his wife, Gertrude, his son George, his daughter Laura, and three grandchildren: James, Carolyn, and Connor. A memorial session is being planned in his honor at the National Radio Science Meeting in Boulder, Colorado, in the year 2000.

D.G. Dudley, E.P. Krider and B.K. Sternberg



# Abu Simbel Radio Telescope Project in the Upper Egypt

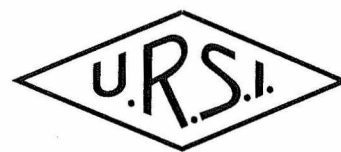

Mosalam Shaltout

## Abstract

This paper shows the importance of building a radio telescope at Abu Simbel in the South of Egypt as part of the European VLBI Network (EVN) to cover the gap between the radio telescopes in Western Europe and the radio telescope at Hartebeesthoek in South Africa. The telescope can be used for solar and stellar observations at wavelengths ranging between centimetres and millimetres, and for geodetic VLBI studies. The suggested diameter 32 meters of the telescope and it is expected to work in the frequency range from 1.4 to 43 GHz. Abu Simbel characterised by excellent atmospheric transparency, dry climate, and low population without any artificial interference. The co-operation of international interested institutions is being explored.

## Introduction

In the earliest days of Radio Astronomy, compact cosmic radio sources were often referred to as 'radio stars' although the vast majority were subsequently revealed to be extragalactic in origin. With the advent of sensitive interferometric arrays in the 70s and early 80s, however, bona fide stellar objects were detected, and by the mid-80s, the study of radio emission from stars was a burgeoning new field of study. The study of radio emission from stars overlaps, in several important respects, with the study of radio emission from the sun. While solar radio physics finds its roots in the very earliest days of radio astronomy, it continues to thrive, especially so in recent years. Particularly important have been new instruments and techniques (e.g. the new 17 GHz radioheliograph at Nobeyama, the OVRO frequency agile solar array), the advent of multi-wavelength observations of solar phenomena, high resolution spectroscopy at decimetric wavelengths, and millimetre wavelength interferometry of active phenomena [1]. In recent years, developments have taken place in the techniques and instrumentation used for ground-based astronomical observations at millimetre and submillimetre wavelength. The wavelength band of interest

(5mm to 300  $\mu$ m) is determined both by the nature of the instrumentation, and by the opacity of Earth's atmosphere [2]. The frequency range above the oxygen absorption band at 69 GHz (wavelength less than 5mm) have been allocated to various services, but until recently only a few (military) applications have used these high frequencies on the other band, radio astronomers use the spectrum in the various atmospheric windows up to frequencies of 1000 GHz in order to observe numerous lines from many molecules. This picture is changing rapidly as new technology is becoming available [3].

World-wide Very Long Baseline Interferometry (VLBI) has undergone a major expansion in capability in recent years. The new US Very Long Baseline Array (VLBA) has produced some eye-catching results. Its counterpart in Europe, the European VLBI Network (EVN) has almost completed major upgrade of the radio frequency performance and flexibility of its member telescopes and their VLBI equipment, as well as constructing a new state-of-the-art correlator. In the southern hemisphere the Australian VLBI array was also expanded its capabilities with a new correlator and recording terminals, and together with radio observations in the Asia Pacific region has began regular co-ordinated VLBI observations as the Asia Pacific Telescope (APT). Millimetre-wave observatories across the globe have also banded together to form the Co-ordinated Millimetre-VLBI Array (CMVA) which observes at 86 GHz three times a year [4], (see figure 1). And perhaps the most spectacular of all, the space VLBI era began in February 1997 with the launch of the Japanese Muses-B Satellite carrying an 8-m diameter radio telescope into earth orbit. The mission, called VSOP (VLBI Space Observatory Programme), combined the space borne antenna (HALCA) with its ground-based counterparts around the world to form radio interferometers of dimension 32000 km and maximum angular resolving power of 80 micro arcseconds. Russia plans to launch its 10 m diameter RADIOASTRON satellite into an even higher orbit than

---

*Professor Mosalam SHALTOUT*  
*National Research Institute of Astronomy and Geophysics*  
*Helwan - Cairo, Egypt*  
*Fax : (202) 5548020 , Phone (202) 2630833*  
*E-mail : mamshaltout@frcu.eun.eg*

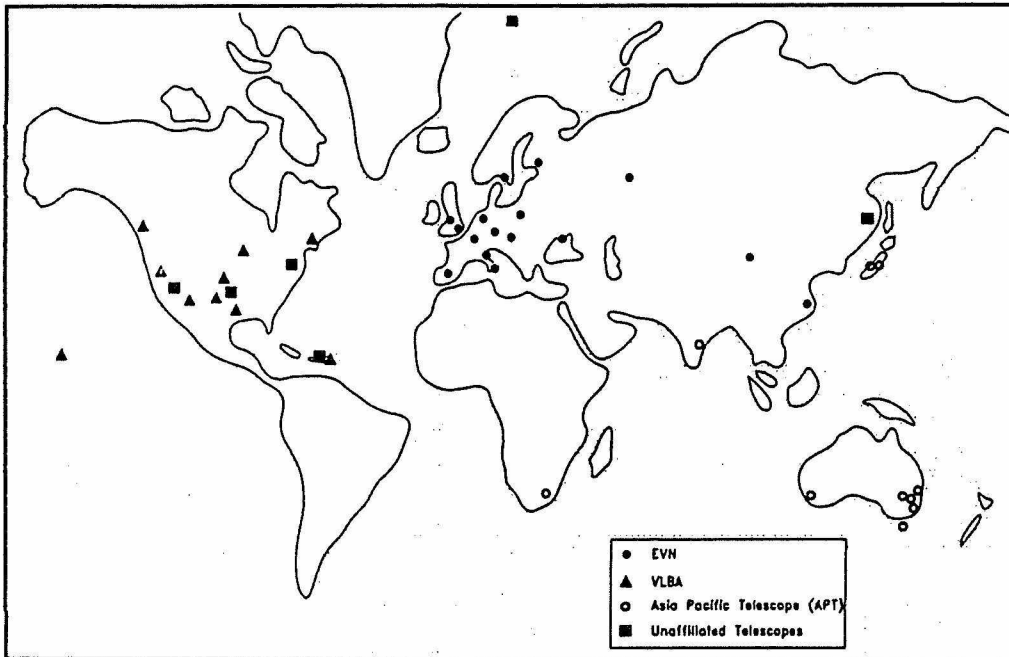
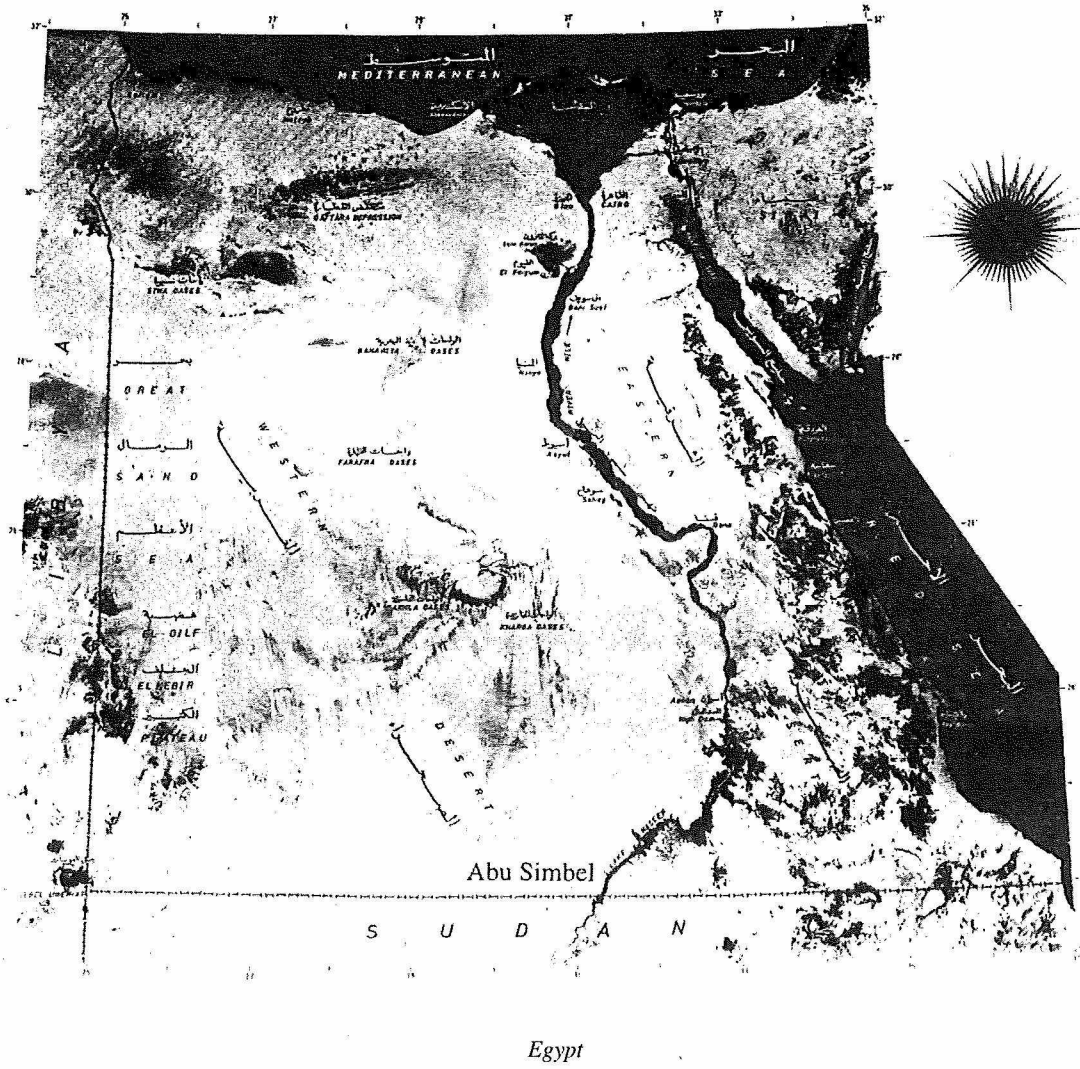

Fig.1 - The world of VLBI; filled circles : EVN; filled triangles : VLBA; open circles : Asia-Pacific Telescope; filled squares : unaffiliated telescopes [4].



VSOP to provide a further increase of three in angular resolving power to 30 micro arcseconds.

In this contribution, attention is drawn to the importance of building a radio telescope at Abu Simbel in the South of Egypt for solar and stellar observations at wavelengths ranging between centimetres and millimetres. Abu Simbel is one of the best sites in the North of Africa for optical and radio observations; it is a dry desert with excellent atmospheric opacity. Also, we hope the telescope will become a part from the European VLBI Network (EVN) for astronomical and geodetic observations.

### Very Long Baseline Interferometry (VLBI)

The angular resolution of a single telescope is given by  $\alpha = 1.22 \lambda / D$  with D as the diameter of the telescope. The angular resolution is  $\sim 10''$  for observations at 3.5 mm, the shortest wavelength of the big 100m telescope at Effelsberg, Germany. This telescope has been successfully operated by the Max-Planck- Institute for Radio Astronomy in Bonn, Germany since 1972 [5]. With its diameter of 100 m it is still the largest fully steerable radiotelescope in the world. The large collecting area of about 7850 m<sup>2</sup> allows the detection of extremely weak radio signals in the order

of milli jansky (Jansky is the unit of the radio flux :  $1 \text{ Jy} = 10^{-26} \text{ W Hz}^{-1} \text{ m}^{-2}$ ). This angular resolution ( $\sim 10''$ ) for the largest fully steerable radio telescope in the world was far away from what astronomers need to investigate for example the cores of radiogalaxies and quasars. But combination with other radio telescopes in Very Long Base Line Interferometry (VLBI) provides the required high angular resolution. The idea behind VLBI is simple : A network of several telescopes in various countries is created to observe the same radio sources simultaneously with the individual telescopes using interferometric properties of electromagnetic radiation as well as the earth's rotation. The angular resolution of the Network is given from the baseline of the most distant telescope. An angular resolution of  $10^{-4}$  arc seconds is achieved by transatlantic VLBI observations.

### The European VLBI Network (EVN)

In 1980, the European VLBI Network (EVN) was created with five founding members. The EVN now consists of 12 institutes with 16 radio telescopes in Europe and China (see table 1). The member institutes of the EVN agreed to spend observing time for 4 sessions of at least 3 weeks each per year. Most frequently observing sessions are at 1.3 cm, 3.6/13

cm, 6 cm, and 18 cm, and part of each period is spent observing in combination of the American Very Long Baseline Array (VLBA) consisting 10 antennas spread over the United States. Recently a dedicated mm-Network has been created to perform the step to VLBI observations at 3 mm wavelength.

The European stations : 100m RT, 30m - MRT of IRAM in Spain, one 15m-telescope of the IRAM interferometer on Plateau de Bure in France, and the Onsala observatory in Sweden participate together with the Haystack Kitt Peak, Owens Valley observatories in the USA, and Sest in Chile.

Participation of the VLBA antennas is expected in the near future [5].

A major upgrade of EVN Facilities is almost complete, made possible by funding from multi-national sources in

Table 1

Country	Location	Institute	Telescope Diameter(m)	Frequency Range (GHz)
Spain	Yebes	National Astronomical Observatory	14	2.3 - 43*
Italy	Bologna	Istituto di Radioastronomia	32	1.4 - 43
	Noto	Istituto di Radioastronomia	32	1.4 - 43
The Netherlands	Westerbork	Netherlands Foundation Research in Astronomy	14 x 25	0.3 - 8.4
United Kingdom	Jodrell Bank	Nuffield Radio Astronomy Laboratories	76	0.3 - 1.6
		Nuffield Radio Astronomy Laboratories	25	1.4 - 26
	Cambridge	Nuffield Radio Astronomy Laboratories	32	1.4 - 43
Sweden	Onsala	Onsala Space Observatory	25	2.3 - 8.4
			20	2.3 - 100
Finland	Helsinki	Metsaehovi Radio Research station	14	22 - 100
Germany	Effelsberg	Max-Planck-Institut für Radioastronomie	100	0.6 - 85
	Wetzell	Technical University of Munich	20	2.3 - 8.4*
Poland	Torun	Torun Astronomy Centre	32	0.3 - 43*
Ukraine	Simeiz	Crimean Astrophysical Observatory	22	0.3 - 43*
China	Shanghai	Shanghai Observatory	25	0.3 - 22
	Urumqi	Urumqi Observatory	25	0.3 - 22

\*Notes:= Frequency range not yet full equipped.[5].

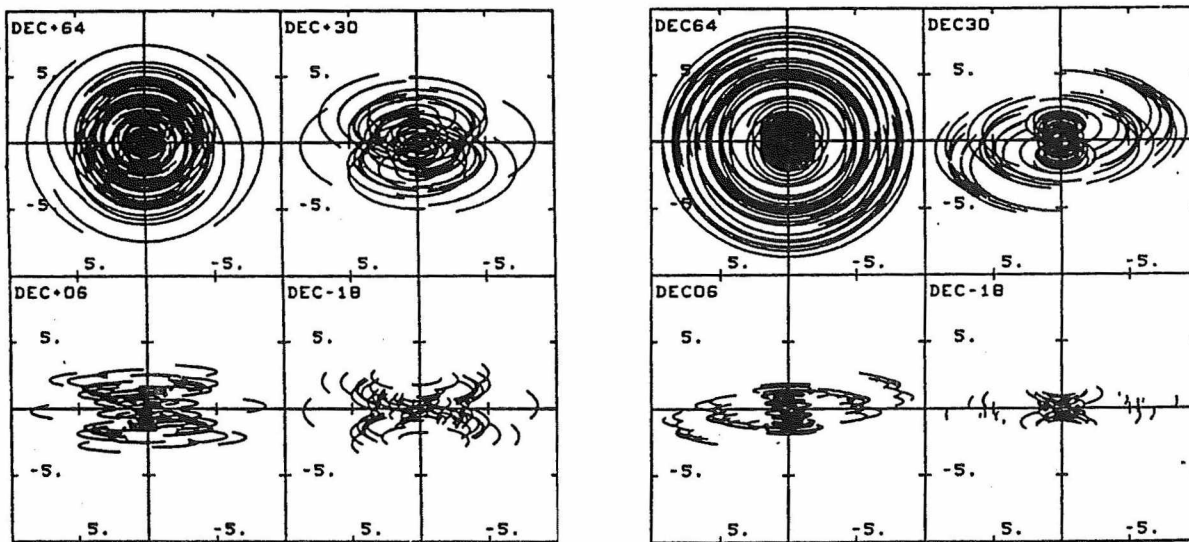

Fig. 2 - left : uv-coverage for the VLBA at declinations of  $^{\circ}$ ,  $30^{\circ}$ ,  $6^{\circ}$  and  $18^{\circ}$ . Units are  $10^3$  km . right : uv-coverage of the EVN at 22 GHz. Telescopes in the EVN are Yebes, Jodrell Bank, Cambridge, Effelsberg, Onsala, Bologna, Noto, Mets" ahovi, Torun, Urumqi and Shanghai (see Table 1). Units are  $10^3$  KM [4].

Europe recently integrated. The main aspects of the upgrade are the construction of a 16-station data processor at the Joint Institute for VLBI in Europe (JIVE) in Dwingeloo (the Netherlands). Upgrade of the individual telescopes to allow recording at 1024 Mbit/ sec (the MKIV standard), and the employment of support scientists at JIVE and at some individual observatories to provide assistance for users of the EVN and other arrays. In addition, a number of nationally funded upgrades are being carried out at EVN member stations including receivers in new frequency bands as mentioned earlier, and replacement of older receivers with state-of-the-art HEMT-based systems[4].

### Radio Telescope at Abu Simbel will solve the problem

Considerable effort went into the optimum placing of the VLBA antennas for uv-coverage. No such license was available for the EVN; the telescopes are where they are. Figure 2 depicts the uv-coverage for the EVN at 22 GHz in 1996. The coverage is good at northern declinations where radio sources pass overhead at the majority of telescopes, but gaps appear at lower declinations and the coverage becomes more one-dimensional the closer the sources are to equatorial. A telescope near the equator between Europe and the South African telescope at Hartebeesthoek would help solve this problem [4]. Abu Simbel is small village on the Western bank of Nasser Lake in the Upper Egypt, with co-ordinates latitude  $22^{\circ} 20. 22' N$ , longitude  $31^{\circ} 36.97' E$ , and altitude 200 meters above the sea level. It is approximately mid-way between the Northern west telescope in the EVN and South Africa, and it completely satisfies two important requirements for modern radio observatories:

- \* A site far from population centres, which affords them a degree of freedom from artificial interference[6].
- \* The dry atmosphere conditions necessary for high frequency radio astronomy [7].

The total population of Abu Simbel is not more than 5000 persons, they mostly work in the field of tourism due to Abu Simbel temples of Pharaon Ramses II. It is 270 km

south of Aswan, with a small local electric grid. Its climatic conditions are extremely favourable for astronomical observations in general ; the atmospheric transparency is excellent, and the site almost cloudless all the year round. The annual mean value of precipitation is 1 mm and evaporation per day is 20mm. The humidity of the air in summer is less than or equal to 13%, and in winter 37%. The mean yearly air temperature is equal to  $+ 26^{\circ}C$ , in January it is  $+ 16.7^{\circ}C$  and in July  $+ 33.7^{\circ}C$ . Minimum and maximum values of air temperature reach  $+ 2^{\circ}C$  and  $+ 50^{\circ}C$  once in some dozens of years. The total sky cover per day is one oktas (cloudness unit) as annual mean. Abu Simbel has an international airport with a low traffic density (three or four aeroplanes per day) for tourism. This will be helpful for the fast transport of the magnetic tapes of observations to the EVN Data processor at JIVE. In Abu Simbel, there are two hotels of 3 and 5 stars level, and the institute guesthouse can be used as a base for further detailed studies of the site and climate before the final decision on the location of the telescope. The suggested radio telescope in Abu Simbel will be similar to three radio telescopes in EVN, two in Italy at Bologna and Noto and operated by Istituto di Radioastronomia, the third in United Kingdom at Cambridge, and operated by the Nuffield Radio Astronomy Laboratories. The diameter of the telescope will be 32m, and it work in the frequency range from 1.4 to 43 GHz (see Figure 3). The climatic conditions in Abu Simbel are ideal for centimetre and millimetre radio observations. The co-operation of international interested institutions and organisations is being explored. The telescope will be the newest instrument in our Institute which carried out search in basic space science and geodesy. Our institute was established in 1903, and contains the largest optical telescope in the Middle East, the 74" Telescope of Kottamia observatory, opened in 1963.

### Egyptian Experience in Radio Astronomy

The author obtained on M.Sc. from Cairo University in 1973 in the field of 'Solar Radio Emission Variability' [8],



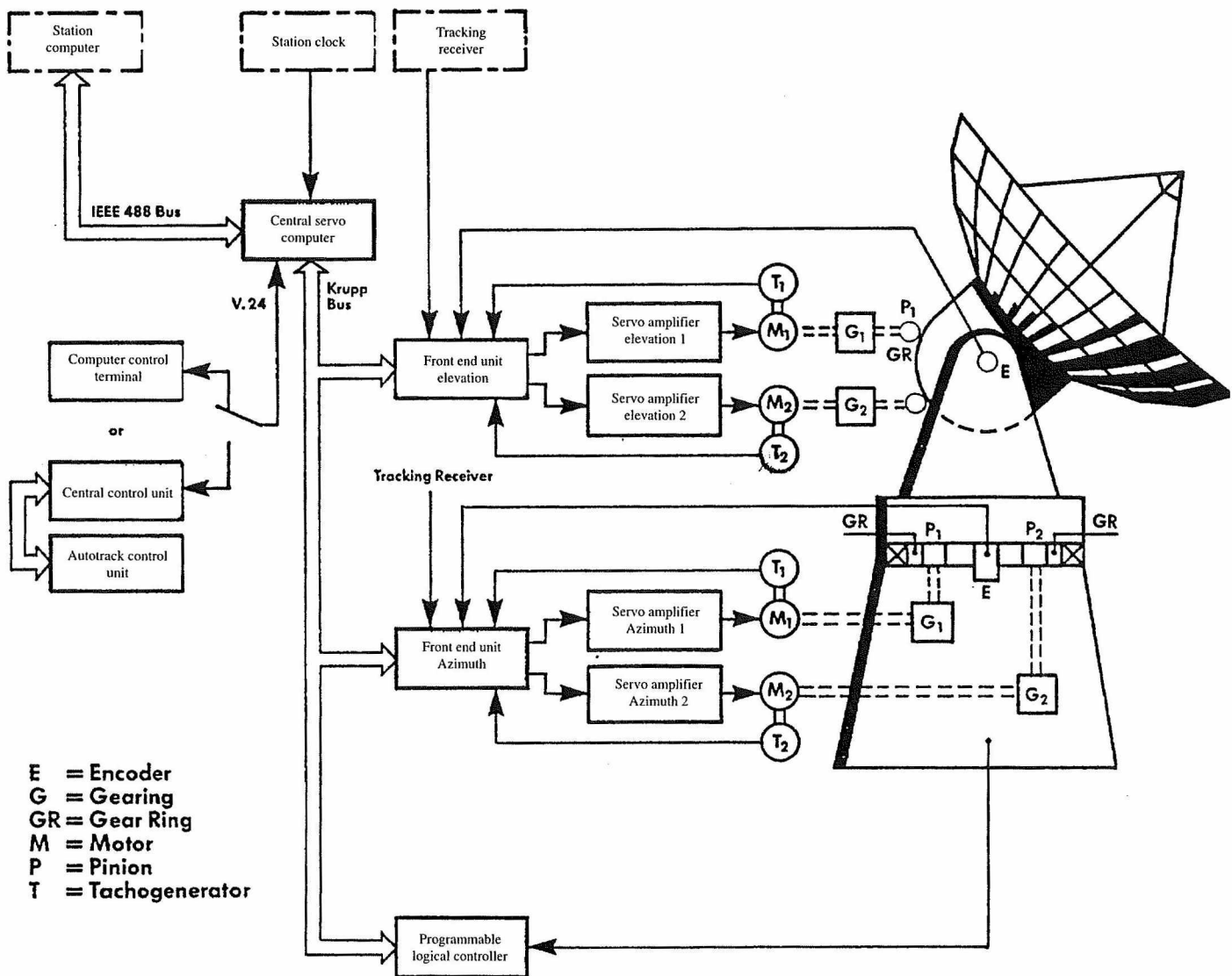

Fig. 3 - Outline of the suggested Radio Telescope at Abu Simbel in the Upper Egypt

and on Ph.D. from Cairo University in 1977 in the field of 'Solar Microwave Bursts' [9]. He worked at the Trensdorf Solar Radio Observatory near Berlin-Germany for one year in 1974, for data collection for Ph.D. Thesis. He visited Max-Planck-Institute for Radio Astronomy in Bonn, and 100 m radio telescope in Effelsberg, Germany in 1997 and 1998. He is an URSI Correspondent and the National Representative of Egypt in Commission J on 'Radio Astronomy'. Also, he is a member and the National Representative of Egypt in COSPAR and a member of the IAU. The Egyptian National Radio Science Committee contains experts in the field of antennas and receivers from the faculties of Engineering in different Egyptian Universities, as well as the Faculty of Military Technique, and other civil ministries.

### References

1. Report on the International Meeting on 'Radio emission from the stars and the sun', Barcelona, Spain, 3-7 July 1995, hosted by University of Barcelona, (1995).
2. John E. Carlstrom and Jonas Zmuidzinas; Millimetre and submillimetre techniques, Review of Radio Science 1993-1996, PP. 839-882, edited by W. Ross Stone, Oxford Science Publications, (1996).

3. W. A. Baan, Annual Report from IUCAF, Radio Science Bulletin No. 281, PP23-26, (1997).
4. R. T. Schilizzi; Current Developments in VLBI Astronomy on the Ground and in Space, Radio Science Bulletin No. 273, PP. 14-28, (1995).
5. R. Schwartz; The Activities of the Max-Planck-Institute for Radio Astronomy (MPIFR) Under the Aspect of Scientific-Cooperation P.E. Very Long Baseline Interferometry, Invited paper No. 2, Proceedings of the Fourteenth National Radio Science Conference (NRSC97), Cairo-Egypt, March 23-25, 1997. Published by the Egyptian National Radio Science Committee, Academy of Scientific Research and Technology, Cairo, Egypt, (1997).
6. M. Ishiguro and radio protection group in NRO; Radio Interference at Nobeyama Radio Observatory, 23rd General Assembly of International Astronomical Union, August 17-30, 1997, Kyoto, Japan.
7. Joshua Roth; Will The Sun Set on Radio Astronomy, Sky and Telescope, April 1997, PP. 40-43, (1997).
8. M. A. Mosalam Shaltout; Study of the Variation of the Solar Radio Emission Components in Relation with 11 Year Cycle, M.Sc. Thesis, Cairo University, Faculty of Science, (1973).
9. M. A. Mosalam Shaltout; Regional and Temporal Variation of the Energetic Processes in the Solar Flares in H-alpha Line and Microwave Region, Ph.D. Thesis, Cairo University,



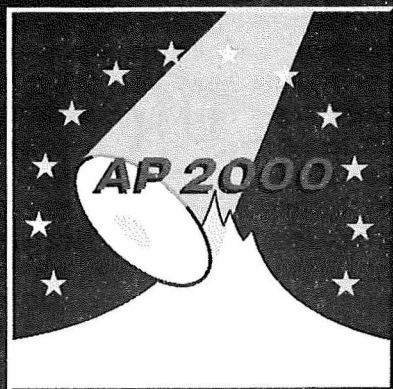

# Millennium Conference on Antennas & Propagation

Davos, Switzerland, 9-14 April 2000

*Exceptionally to celebrate  
the Millennium ICAP & JINA meet in 2000*

<http://www.estec.esa.nl/AP2000/>

Contact: ESTEC Conference Bureau  
Postbus 299  
2200 AG Noordwijk, The Netherlands

Tel.: +31 71 565-5005  
Fax: +31 71 565-5658  
e-mail: [confburo@estec.esa.nl](mailto:confburo@estec.esa.nl)

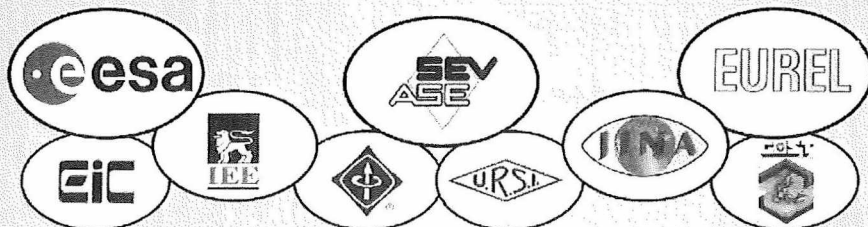

# The Mir Space Station Ionospheric Sounder

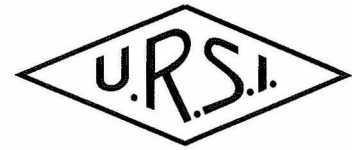

N. P. Danilkin

An ionospheric radio-sounding experiment on the MIR Space Station has now begun in Russia. The equipment is located on the MIR Station, can store ionospheric information during MIR passes over various regions, and can also immediately transmit ionospheric information about zones over which it flies. We invite everyone who is interested in real-time ionospheric information to co-operate with us using the monitoring system onboard MIR.

## Introduction

The first ionosonde satellite was launched—Allouette-1 on 1962. A series of ionosondes was launched during the 60s, 70s and 80s: Allouette-2; ISIS-1, ISIS-2; Explorer-XX, ISS-b, ISS-c (Japan), Intercosmos-19, and Cosmos-1809 (Russian). These gave us a vast ocean of ionosphere knowledge, allowing us to work up a new theory of ionosphere-magnetosphere interaction.

However, monitoring of an ionosphere is carried out nowadays by ground ionospheric stations still. Between that, the radiosounding from satellites has advantages before ground-based stations sounding:

1. The network is helpless when total radio waves absorption in the ionospheric D-region occurs.
2. The network is inhomogeneous. In some places the absence of stations is irreplaceable (for example, near the planet's poles and over the oceans).
3. Measurement of the topside ionosphere is impossible from the ground, but the role of the topside ionosphere will increase as trans-ionospheric radio communication lines are developed while variations in ionospheric disturbances limit the possibilities of their practical application.
4. The ground network does not allow continuous measurement of electron concentration dependence along any direction to take account of horizontal gradients.

5. The ground network is unable to trace the movement of local ionospheric disturbances and plasma waves.
6. Last, but not least, the main argument for today is as follows: It is necessary to measure the dynamical regime of the ionosphere life, especially the rhythmical changes of the electron cover of the Earth. Because now we understand—especially from studies of the database from the experiment with Intercosmos-19—that the main influence of space weather on the Earth's atmosphere is the rhythmical changes of plasma cover of our planet. If earlier we measured the static characteristics of the topside and bottomside ionosphere in different experiments, nowadays we must measure and see the picture of the dynamic life of the plasma of the Earth's atmosphere cover. Especially here the peculiarities of the dynamic processes determine many of the rhythmical properties of the bottomside ionosphere and of the biosphere as a whole.

Therefore is obvious, that the ionospheric monitoring is necessary to realise in 21 century by system radio sounding, which components are both ground, and satellite radio soundings.

Major condition of ionospheric monitoring from space is it the constant character and possibility of a cyclical replacement of out-of-date or spoiler of ionospheric sounders on new. Really, even first from ionospheric sounders - Allouette-1 (by the way, on many performances - best from all) would be quite suitable and today for work, if on it to replace power supply units.

For this reason it is necessary to think over and experimentally to investigate a problem on a possibility of radiosounding from habitable space stations, on which the problem on cyclical deliveries and replacement of various details is made rather easily.

We have tried to make it by installing our ionospheric sounder in the MIR habitable space station.

---

*Professor Nicholas P. Danilkin  
International Scientific and Technical Centre of Payloads  
of Space Objects  
Fedorov Institute of Applied Geophysics  
Rostokinskaij ulitza 9  
Moscow, 129128, Russia  
Tel + 7 095 187 8186  
Fax + 7 095 583 6343, E-mail: nickd@orc.ru*

## Target information

An ionospheric sounder is installed on the MIR space station. One applied problem that it is intended for is real-time monitoring of the ionosphere and the determination of radio communication parameters. In this mode, the ionospheric sounder makes an ionospheric radiosounding on order from the ground and simultaneously transmits the resultant ionogram to the ground on a special radio channel with the frequency 137.85 MHz. This ionogram information can be received using a simple fixed antenna and receiver attached to a computer. The ionospheric operating parameters are determined from one or several ionograms. A global model of the ionosphere is then corrected using these parameters before making estimates of radio communication conditions. All information processing and radio communication parameter calculations are made on this computer. The target information is the estimated Maximum Usable Frequency (MUF) and Lowest Usable Frequency (LUF) for an ionospheric radio communication link.

## The planetary ionosphere zone inspected by the MIR ionospheric sounder

The orbit inclination of station is 52°.

### Method

Radiowave reflections from the ionospheric plasma and reflections from the Earth's surface are observed with the Mir Ionospheric Sounder. The signal delay for one double passage through the ionosphere is used. Radiowaves in the range 300 kHz to 16 MHz, with pulse duration of 133 msec

are used. The group delay and amplitude of pulses after their passage from MIR up to the ionospheric maximum (topside or bottomside sounding) or down to the Earth and back (a double trans-ionospheric sounding) are recorded. The calculation of the main ionospheric parameters (critical frequency in F layer, foF2, height of a maximum, hmaxF, and F layer half-thickness, q) is estimated. For the MUF determination one or more ionograms (usually no more than 3 - 5) is used from which foF2, hmaxF and q are estimated. These data are the basis for a mathematical model of the ionosphere and all the radio communication parameters can be calculated using it.

### Instrumentation

Frequency band : From 0,3 up to 15.95 MHz  
Number of sounding frequencies : 338  
Sounding pulse duration : 133ms  
Intervals of sounding : 50 kHz  
Output power : Not less than 250 W  
Sounding range : Up to 1800 km  
Virtual distance accuracy : 10 km  
Receiver sensitivity, signal / noise on an output equal 3, : Is not worse 5mV  
Receiver dynamic range : Not less than 60 dB

### Antenna system

Two pins with a variable length located on the block PRIRODA of the MIR space station under an angle 100 degrees are used. The complicated external surface of station MIR requires a special preliminary adjustment of system "ionospheric sounder antenna - Mir station external surface".

*Ionogram samples :*

Satellite name: Mir

Date: 04.11.1998 Time: 07:41:12 Orbit: 602 Frame: 40

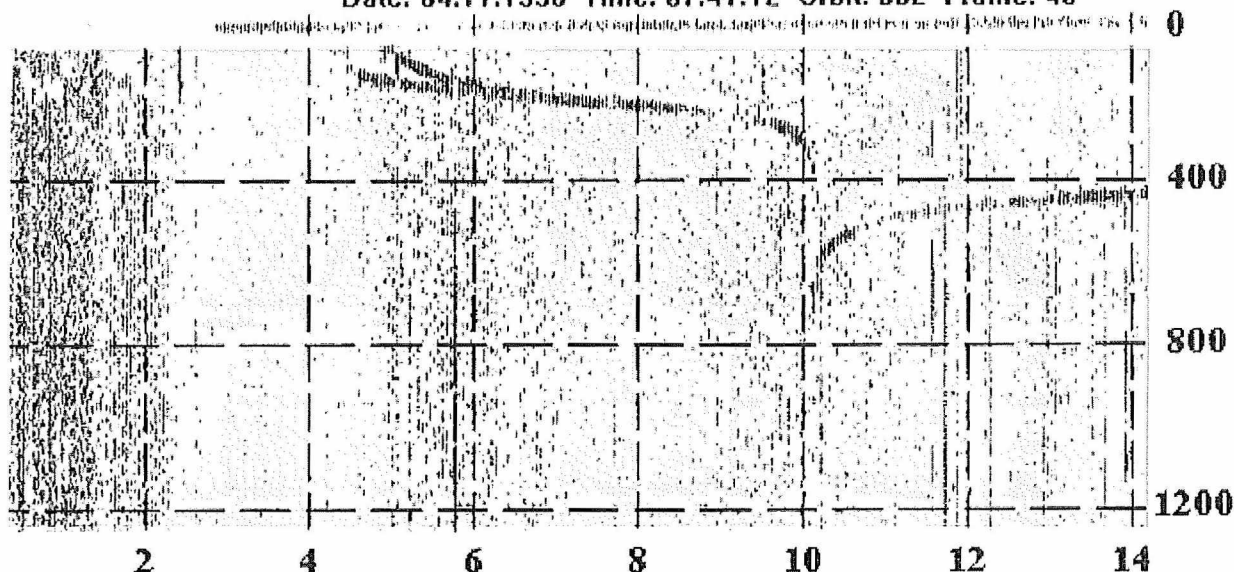



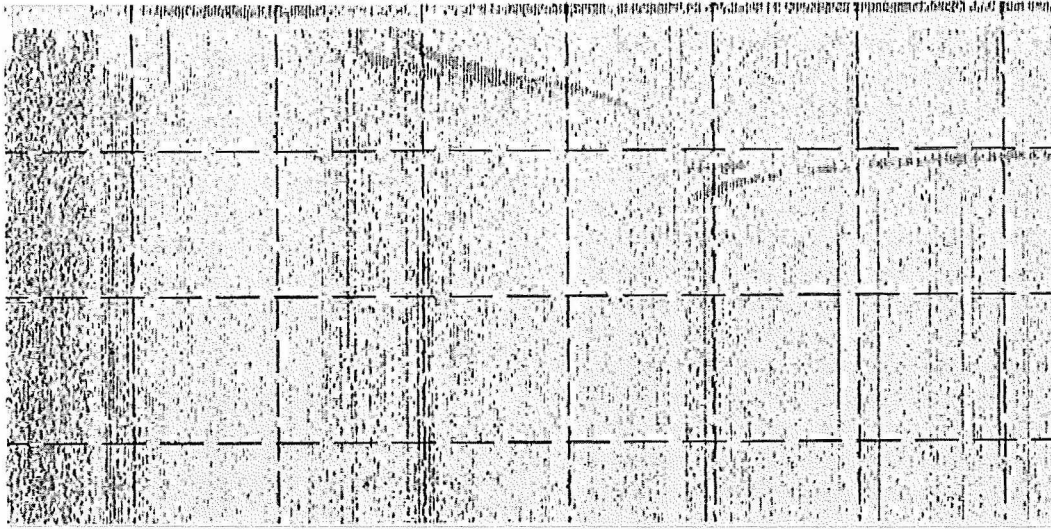

Satellite name: Mir Station:

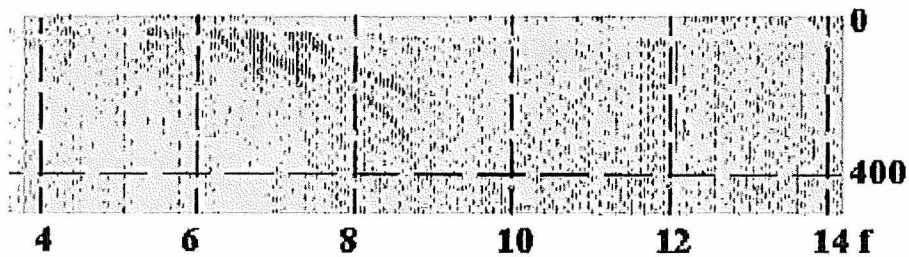

**Output data**

1. A mathematical model of the ionosphere is corrected using the real-time MIR ionospheric sounder data. All the necessary parameters for radio wave propagation in the observed ionosphere are determined. Signal trajectories for various radiation angles are shown in the next figure and the results of calculations are sketched in lower part of

this figure, namely:

- the integrated absorption of a radio wave using the divergence factor,  $G_s$
- the integrated group delay

The diurnal prediction of MUF and LUF schedule for a radio link with a mid point above the Atlantic ocean is shown is indicated in the next Figure. Actual and predicted

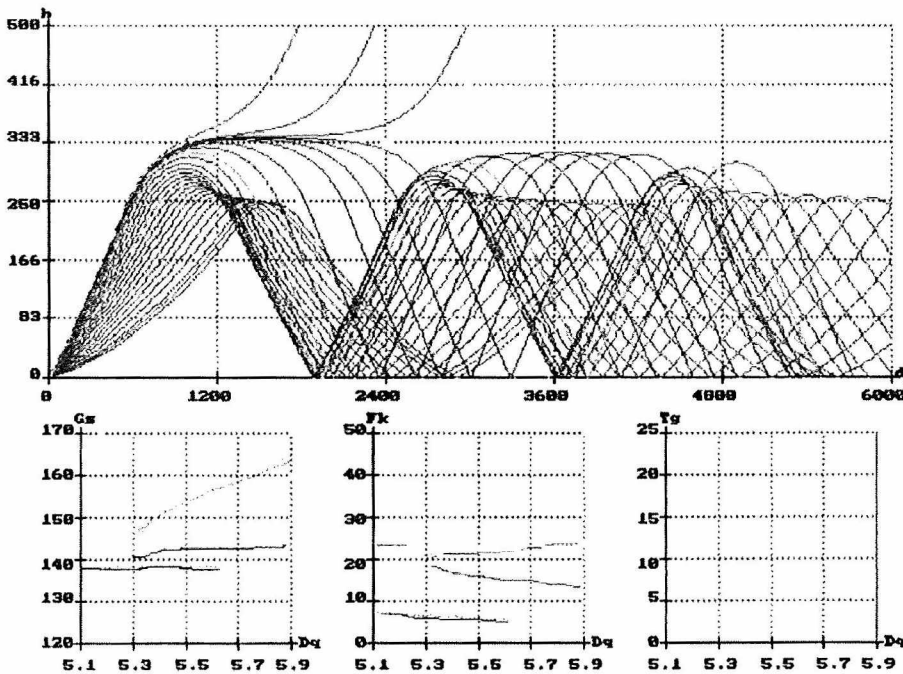

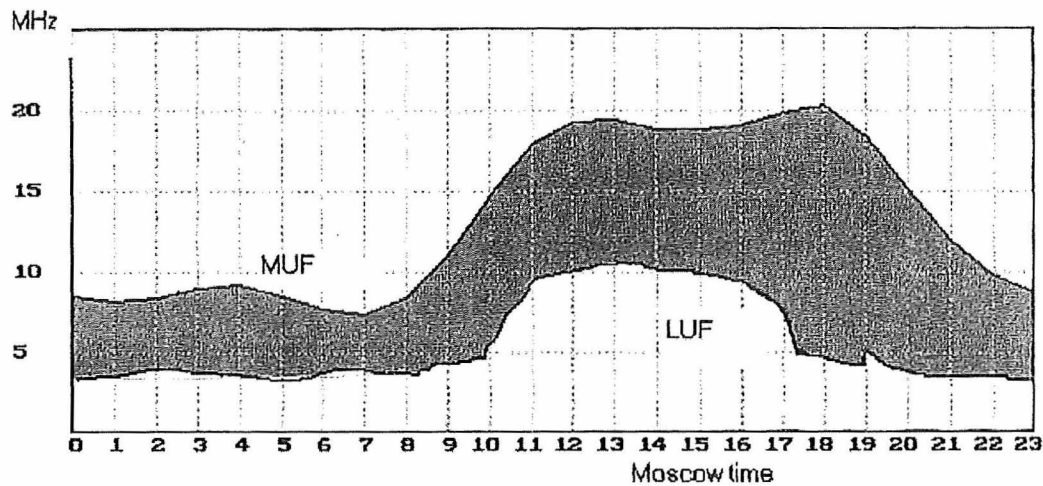

MUF and LUF values, as experiments have shown, practically coincide for the first 4-6 hours in undisturbed ionospheric conditions. The difference is greater the further the forecast is from time of measurement.

### Conclusions

We expect that ionosondes on habitable space stations in the XXIst century should be capable of simultaneous operation in the four types of radio sounding (vertical, oblique, topside and transionospheric) and thus together

with ground stations to diagnose the spatial distribution of the bottomside and topside ionosphere of characteristics for radio wave propagation comprehensively.

### References

- [1] Danilkin N.P., J. atmos. terr. Phys, vol.56, no. 11, pp. 1423-1430, 1994.
- [2] Danilkin N.P. and G.M. Viseman, J. geomagn. aeron., vol 37, no. 1, pp. 191-194, 1996.



# Summary Report of the Strategy Meeting

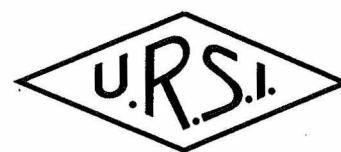

The URSI Strategy Meeting was held in Toronto on April 30, 1998 where most of the Commission Chairs (and/or Vice Chairs) were present, together with the Board members and some additional participants from the Long Range Planning Committee. A very intensive discussion was held and its detailed Minutes are available on the URSI Homepage at url <http://www.intec.rug.ac.be/Research/Projects/ursi/fulstrat.htm>. The following is a summary of the intensive discussion associated with each agenda item, which we hope may be useful as a digest.

## Introduction

Prof. Sagi Chair of the Electrical Engineering Department of the University of Toronto welcomed the attendees of the URSI Strategy Meeting. URSI President Tom Senior briefly reviewed the purpose of URSI. He outlined significant changes in URSI's organisation and operations, as well as examples of URSI's outreach, over the past decade. Hiroshi Matsumoto, Chair of the Long Range Planning Committee, then reviewed how the Strategy Meeting came to be and its purpose.

## Relations with ICSU and other Unions

The relationship between URSI and ICSU was summarised. Recent changes in ICSU's organisation make it probable that the financial support of ICSU for URSI will be reduced, and it will remain difficult for URSI to have a major role in ICSU. ICSU-grant money will be given to focused programs, rather than to the scientific unions. It thus may be available to URSI, but URSI will have to bid and compete for it.

- The major way URSI currently interacts with other scientific unions is through inter-union scientific bodies such as COSPAR, SCOSTEP, IUCAF and FAGS, involving many individual Commission members.
- It was noted that while financial support from many nations for scientific unions is declining, support for ICSU has remained strong. This is in part due to the fact that the national organisations supplying the money are members of ICSU, but not of the scientific unions.

## Relations with ITU

- URSI has long-standing ties with the ITU, although lately, these have been less successful. The ITU has changed, and is now primarily responsive to commercial interests and industrial members, most of which have no interest in URSI.
- URSI needs to collaborate with the ITU through such forums as COMMSPIRE and the Working Group

chaired by Paul Delogne, and through individuals who are active in both the ITU and URSI.

- Our objective should not be the ITU, but the problem that the ITU is trying to solve: how to develop communication in a more effective way. Our role should be to protect science.
- In addition to continuation of symposia and discussion forums with the ITU, we should encourage the holding of joint sessions with the ITU, and involving ITU people within URSI.

## Relations with Standardisation Bodies

- URSI is currently not directly involved in creating standards. However, there are opportunities where international leadership is needed, and URSI could have a significant impact. Standards for human exposure to EM fields is an example of an area needing such leadership.
- Although modest funding would be needed to support such an effort within URSI, it should be possible to solicit such funding from member countries and industry. ICSU might also support such an effort.
- Although URSI cannot set standards, it can create them, with sound scientific basis, for adoption by national and trans-national bodies. This could be of particular value for countries that do not have the resources to develop such standards on their own.

## Relations with Professional Societies

- URSI deals with ICSU and the UN, and countries are its Members. Professional societies typically deal with a particular field, and individuals are their members. URSI's technical fields are typically much broader than those of professional societies.
- However, URSI and professional societies have common aspects: the individuals involved; conferences; publications; and the ultimate "customers," the users of their science.
- In looking at the technical-interest overlap between URSI and the IEEE, all Commissions except for J have overlap with multiple IEEE Societies. Commissions A through H have overlap with at least four Societies; some overlap with as many as 10 IEEE Societies. The IEEE Aerospace and Electronic Systems, Antennas and Propagation (AP-S), Communications, Geoscience and Remote Sensing, and Microwave Theory and Techniques Societies each have overlap with four or more URSI Commissions. AP-S has overlap with all

URSI Commissions but Commission C.

- Mechanisms for co-operation between URSI and professional societies include joint conferences (the long-standing and highly successful joint IEEE AP-S/USNC/URSI meetings are a possible model), and joint publications. In addition to advantages for scientific exchange, joint conferences can be a source of very significant revenue for URSI (e.g., \$50-\$80K per meeting to the USNC/URSI from the joint meetings).

### **Relations with Industry and General Public**

- One method of outreach in this area is through conferences: COMMSPIRE is an example.
- The LRP needs to address some questions: Should industry be an URSI customer? If so, how does URSI serve industry, and what does URSI get from industry in return?
- Several examples of successful industrial support of scientific organisations—without the organisations becoming controlled or dominated by industry—were cited.
- URSI's outreach to the general public should be through industry and individuals. Several examples of successful outreach by similar organisations were given, including educational programs and public scientific lectures. The need for more effective representation in the press was identified.

### **Finance and Membership**

- For 1995-97, URSI had a deficit from operations of about 10%, or \$70K, covered by selling assets. The University of Gent's donation of many resources to the Secretariat helped minimise the deficit.
- URSI's revenue could be substantially increased by raising registration fees at meetings: they are much lower than similar meetings, and usually paid by attendee's organisations.
- To increase revenue and reduce loss, URSI should insure that future General Assemblies are organised to provide a certain return to URSI. This would probably require shifting at least some responsibility for the GA from the host country to URSI, and that implies additional needed functions within URSI. The AP-S/USNC/URSI model was cited as one way to do this.

### **Awards**

- URSI currently has four awards : the Balthasar van der Pol Gold Medal, the John Howard Dellinger Gold Medal, the Appleton Prize and the Issac Koga Gold

Medal. There are also the Young Scientist Awards. The scope of the Appleton Prize will probably need to be broadened.

- The possibility of establishing the position of URSI Fellow was discussed, with many opinions expressed. The idea was favoured by a slight majority.

### **The General Assembly**

- It was felt that General Assemblies should have at least one, and perhaps more, themes.
- There are both pros and cons to attempting to focus the number of topics and to reducing the number of sessions at the General Assembly.

### **URSI Publications**

- The *Review of Radio Science (RRS)* and the *Disk* (together, "RRS") continue to be technical successes, and valued by the URSI community. However, the hoped-for breadth of distribution outside of URSI has yet to be realised.
- Oxford University Press has reorganised its science and engineering publishing functions. Although it will publish *RRS* and *Modern Radio Science (MRS)* in 1999 as planned, the future is somewhat uncertain. As an alternative if needed, the IEEE Press is willing to publish these.
- In order to achieve wider distribution, the IEEE Press has agreed to purchase and sell a minimum of 200 copies of the 1999 versions of *RRS* and *MRS*.
- There was strong agreement that starting with the 1999-2002 triennium, *MRS* should be discontinued, and the lectures making up *MRS* should be published in *The Radio Science Bulletin*. Also, for the next triennium, the *Disk* should become a CD-ROM.

### **General discussion**

- There was strong agreement that the Strategy Meeting was extremely valuable, and should be held on a regular basis, perhaps once between General Assemblies and once in connection with the General Assembly.
- The need for a balance between Commission and national membership in URSI was discussed. Since URSI is a delegation of national academies, if there is no national activity, then it should be our goal to revitalise national activities in URSI.
- Although there are many implications that need to be considered, the possibility of holding one-week-long General Assemblies every two years met with significant support.

H. Matsumoto & W. R. Stone



## CURRENT STATUS OF THE SCIENTIFIC PROGRAMME

The September 1998 issue of the *Radio Science Bulletin* (No 286) presented the outline of the Scientific Programme of the XXVIth URSI General Assembly, Toronto, 1999. In this report therefore, I would like to describe the on-going procedure towards the finalisation of the Scientific Programme:

- No later than March 15, the Convenors and Chairs - after discussion if necessary with Co-ordinator (myself) - will inform NRC/Ottawa (the local organising committee) about the accepted/rejected papers and oral or poster presentations.
- At the end of March, NRC/Ottawa will mail the acceptance/rejection letters to the authors. For accepted

submissions and time taken to assign some papers to an appropriate session.

### Number of abstracts per Commission

Table 1 shows the total of Abstracts received on 15 February 1999 at 17.08.

When I compare these figures to the number of abstracts received three years ago, for the Lille General Assembly, there is an increase with almost 200 abstracts. But the greatest difference is that the number of proposed communications of Commission K on "Electromagnetics in biology and medicine" has increased by 50%, and now totals 134.

<b>Commission A</b>		<b>Commission B</b>		<b>Commission C</b>		<b>Commission D</b>		<b>Commission E</b>	
Session A1	8	Session B1	37	Session C1	5	Session D1	5	Session E1	5
A2	16	B2	16	C2	5	D2	5	E2	13
A3	6	B3	56	C3	5	D3	4	E3	9
A4	3	B4	45	C4	11	D4	0	E4	8
A5	3	B5	25	C5	2	D5	10	E5	11
A6	9	B6	18	C6	3	D6	8	E6	25
A7	2	B7	12	C7	3	D7	10	E7	16
A8	5	B8	24	C8	1	D8	10	E8	11
AB1	14	B9	12	C9	19	DB	7	EA	8
AB2	9	B10	10	CF	10	DC1	6	EB	11
AD	8	BD1	23			DC2	5	EF	14
AE	12	BD2	9					Posters	8
		Posters	95						
<b>Total comm. A</b>	<b>94</b>	<b>Total comm. B</b>	<b>382</b>	<b>Total comm. C</b>	<b>64</b>	<b>Total comm. D</b>	<b>70</b>	<b>Total comm. E</b>	<b>137</b>
<b>Commission F</b>		<b>Commission G</b>		<b>Commission H</b>		<b>Commission J</b>		<b>Commission K</b>	
Session F1	19	Session G1	34	Session H1	13	Session J1	15	Session K1	20
F2	19	G2	19	H2	29	J2	42	K2	24
F3	12	G3	24	H4	42	J3	17	K3	12
F4	8	G4	69	HG1	17	J4	19	K4	37
F5	9	G5	22	HG2	25	J5	13	KA	10
F6	9	GC	8	HG3	30	J6	31	KB	19
F7	25	GF	17	HG4	10	JBC	7	KC	5
F8	1	GH1	24	HG5	30	JCEG	10	KE	7
F9	13	GH2	14			JDC	14		
F10	10					JF	13		
FAB	16								
Posters	34								
<b>Total comm. F</b>	<b>196</b>	<b>Total comm. G</b>	<b>231</b>	<b>Total comm. H</b>	<b>219</b>	<b>Total comm. J</b>	<b>181</b>	<b>Total comm. K</b>	<b>134</b>

Table 1

papers, the location where the presentation will be held and the date and time will be indicated, as well as the mode of presentation (oral or poster).

- At the end of April NRC/Ottawa will send out the Second Announcement of the General Assembly.

Table 1 gives an overview - session by session - of the number of abstracts received at NRC/Ottawa. The number of papers in each category may be subject to change; correction or modification, partly because of delayed

On the other hand - and this was already the case for the Lille GA in 1996 - the Commissions C and D (respectively on "Signals and Systems" and "Electronics and Photonics") have difficulties to attract proposals of communications (respectively 64 and 70 abstracts submitted up to now). This is quite unfortunate because the justification of those Commissions are essential to URSI.

Joël Hamelin  
Co-ordinator Scientific Programme

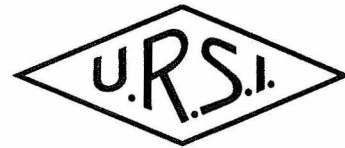

## CONFERENCE REPORTS

### GALILEO FERRARIS AND THE CONVERSION OF ENERGY SYMPOSIUM

Turin, Italy, 27-29 October 1997

The International Symposium Galileo Ferraris and the Conversion of Energy - Developments of Electrical Engineering over a Century - took place in Turin from 27 to 29 October 1997, at the Politecnico; 27 papers were presented, with the aim to analyse the figure of Galileo Ferraris and the developments of electrical engineering regarding conversion and transmission of electrical engineering.

The Dean of the Politecnico, Professor Rodolfo Zich; the President of the Accademia delle Scienze di Torino Professor Elio Casetta; the President of the Istituto Elettrotecnico Nazionale Galileo Ferraris, Professor Sigfrido Leschiutta and the Mayor of the town of Turin participated to the Opening of the Colloquium. Among the several guests, we have to mention Professor Carassa from the Politecnico di Milano and Professor Marenesi e Zingales from the Università di Padova.

The sessions of the Symposium went according to schedule : 27 papers were presented by as many speakers from different countries. France was represented by the CNRS and by the *Institut d'Histoire du Temps Present*,

Hungary by the *Elektrotechnisches Museum* and the *Universitat Miskoic*, Rumania by the *Transylvania University*, the United Kingdom by the *Science Museum of London* and the *University of Teesside*, the U.S.A by the *University of Virginia*. There were many participants from the various Italian universities.

In the afternoon of October 29, when the last session ended, visits were organised to the Museum of Electrical Equipment "Carlo Chiodi" at the Istituto Elettrotecnico Nazionale Galileo Ferraris and to the Museum "Ferraris" at the City Hall of Livorno Ferraris.

The printing of the Proceedings of this Symposium is taken care of by the Press Office of the Istituto Elettrotecnico Nazionale Galileo Ferraris.

We can presume both Italian researchers and foreign ones appreciated the Symposium as we received verbal and written consents.

The organisation of the Symposium was entrusted to the Istituto Elettrotecnico Nazionale Galileo Ferraris' administrative staff.

Sigfrido Leschiutta

### IWTS'98

Shah Alam, Malaysia, 11-15 May 1998

The International Wireless and Telecommunication Symposium/Exhibition (IWTS'98) was held in the ITM Resort and Convention Centre, Shah Alam from May 11-15 1998. The theme of the symposium was "Connectivity for Health and Wealth".

The symposium was preceded by two day of pre-symposium tutorials (11 & 12 May 1998). This annual symposium is of interest to the engineering, scientific communities and telecommunication industry. Three mini-symposiums were held in parallel with the symposium. The IWTS'98 Exhibition forecasting the telecommunication industry entering the 21st century was also held from May 13-15, 1998. The combination of the tutorial sessions,

technical sessions, mini-symposiums, exhibition, social events and the World Telecommunication Day event gives this symposium a unique scientific, technical, business and social experience.

This was the second International Wireless and Telecommunication Symposium/Exhibition. The wireless theory started with Marconi in 1895. Its technologies and applications continued to grow up rapidly and achieved what we are experiencing today in our daily life in general and in the telecommunications industry in particular. The IWTS is a platform, which concentrates on the basic theory and practice of the wireless phenomena and several of its growing up telecommunications technologies.



From the initial stages of developing the IWTS'98, the technical committee eyed two aspects while selecting the technical topics: First to provide a forum for a bigger number of participation from Malaysia and all over the world through interactive presentation and mutual discussion of the relevant telecommunication areas; second to maintain a reasonable technical standard by the selection of only 100 technical papers from 30 countries to be presented in 13 technical sessions (in 3 parallel tracks).

The sessions cover electromagnetic and radiation, antennas and propagation, signal and image processing, mobile, cellular, personal and satellites, multiple access techniques, wireless networks, future systems, and some aspects of related business and services in wireless and telecommunications. The composition of this wide technical program is a major undertaking. It is expected to provide the participants with a rewarding opportunity to discuss various related topics in the telecommunications and related technologies.

The most important aim of this series of symposiums (IWTS) is to provide a link to worldwide participants of academic institutions, industry leaders and political groups involved in the decision making of the telecommunication industry. In order to achieve this, it is necessary to:

- Introduce the technologies of telecommunications in general and the wireless, cellular, personal and satellite in particular to the growing research and development sector in the region as well as the telecommunication industry. Presently, this important technical area gains

a significant attention worldwide. The same kind of attention should be given in the region as well.

- Focus on major areas in wireless and telecommunications which are expected to be key technical features in the near future, like the mobile satellite communications, high speed networks, multiple access techniques and the uprising multimedia communications and information Technology.

While achieving these two major targets, it is necessary to go all the way in addressing the nation's telecommunications needs and problems.

In general, IWTS accommodated the following major activities:

- Pre-symposium Tutorials: This was an activity of two days (11-12 May 1998). Presenters presented thirteen (full day tutorials) from various parts of the world.
- Technical Sessions: 13 parallel technical sessions were presented between 13-15 May 1998. There were paper presenters from almost 25 country. They presented research work at various fields of wireless and telecommunications. The symposium came up with special proceedings for these technical papers.
- Mini-symposiums: The IWTS'98 organized three mini-symposiums namely: information technology infrastructure; global bridges via satellites; telecommunications: standards, services and applications.
- IWTS'98 Exhibition: The purpose of the exhibit is to preserve samples of significant technology advances in the field of wireless and telecommunications.

## BIANISOTROPICS '98

Braunschweig, Germany, 3 – 6 June 1998

From 3 to 6 June 1998, the Technische Universität Braunschweig in Braunschweig, Germany, hosted Bianisotropics '98, the 7<sup>th</sup> in a series of loosely connected international conferences and workshops on complex media. The previous meetings took place in Helsinki, Finland ('93), Gomel, Belarus ('93), Périgueux, France ('94), State College, PA, USA ('95), St. Petersburg-Moscow, Russia ('96), and Glasgow, Scotland ('97). The conference was sponsored by the Commission B of URSI and the IEEE Electron Devices Society. A generous financial support was granted by the German Science Foundation (*Deutsche Forschungsgemeinschaft*), the Government of Lower Saxony (*Niedersächsische Ministerium für Wissenschaft und Kultur*), and the president of the Technische Universität Braunschweig, Prof. Dr. Bernd Rebe. The conference was chaired by Prof. Hans-Georg Unger (Honorary Chairman) and Prof. Arne F. Jacob (Chairman and Organiser), both from the Technische Universität Braunschweig. They were supported by an experienced Organizing Committee (Prof. Parneix, Talence, F; Prof. Serdyukov, Gomel, BY; Prof. Sihvola, Espoo, SF; Dr. Unrau, Braunschweig, D; Prof. Varadan, University Park, PA, USA; Dr. Vinogradov,

Moscow, RUS; Dr. Weiglhofer, Glasgow, UK), a dedicated Scientific Advisory Committee (Prof. Cloete, Stellenbosch, ZA; Prof. Kristensson, Lund, S; Prof. Lakhtakia, University Park, PA, USA; Prof. Lindell, Espoo, SF; Dr. Maksimenko, Minsk, BY; Prof. Suchy, Düsseldorf, D; Prof. Tretyakov, St. Petersburg, RUS; Prof. Whites, Lexington, KY, USA), and a hard-working Local Organising Committee. The conference attracted 75 scientists from 15 countries and four continents. From the 75 contributions that were accepted by the Scientific Advisory Committee 67 were presented during the six half-days. In addition to these regular contributions, the program encompassed seven invited lectures by distinguished scientists. A four-page summary of all accepted papers is included in the Proceedings that can be obtained from the Technische Universität Braunschweig (mail to d.kaehler@tu-bs.de).

In order to avoid parallel sessions the program was split about half and half between oral and poster presentations. The Organising Committee took several measures to boost the attractiveness of the two poster sessions. They were scheduled in the early afternoon and were framed by interesting invited lectures. The posters



were put up in the same hall where the refreshments were served; a duration of 90 minutes and a smooth transition to the afternoon coffee break allowed for fertile discussions in a relaxed atmosphere among the numerous attendants. As an incentive for a high quality presentation the best designed poster was awarded a prize of DM 500.00. The six members of the international Scientific Advisory Committee unanimously chose D. Mamaluy from the University of Kiev, Ukraine. For similar reasons and in the same way, a prize of DM 500.00 was also awarded to the best oral presentation (Recipient: Dr. G. Slepyan from Minsk, Belarus). Following the example of the previous conferences, a one-hour panel discussion was scheduled on Saturday morning. It was led by Prof. John Cloete from the University of Stellenbosch, South Africa. The program was rounded up by the social events, i.e. a welcome reception given by the Mayor of Braunschweig at the medieval Town Hall and a concert followed by the conference dinner.

In accordance with its broad scientific scope, the conference covered a wide spectrum of different subjects. The sessions were organised according to the following categories:

- Mathematical and Canonical Problems
- Material Modelling
- Propagation and Scattering
- Crystallography and Crystals
- Liquid Crystals
- Nanotubes and Related Topics
- Experimental Techniques
- Applications

The program was highlighted by invited talks. These were:

1. "Electromagnetic Effects in Anisotropic Media: Experiment and Theory", Prof. Raab, University of Natal, Pietermaritzburg, South Africa;
2. "In Search for a Possibility to Design Ideally-Matched Composite Absorbing Layers: Higher-order Spatial Dispersion?", Prof. Tretyakov, St. Petersburg State Technical University, St. Petersburg, Russia;
3. "Comparative Review of Homogenization Formalisms for Bianisotropic Materials", Dr. Michel, Jena, Germany;
4. "Chiral Nanostructures and Nanocomposites: Electronic and Electromagnetic Properties", Dr. Slepyan, Belarus State University, Minsk, Belarus;
5. "A Survey of Computational Methods for Computing the Effective Material Parameters of Composite Media", Prof. Whites, University of Kentucky, Lexington, KY, USA;
6. "Canonical Problems for Radiation and Propagation in

Complex Media", Dr. Weiglhofer, University of Glasgow, Glasgow, UK;

7. "Batman presents: Applications of Sculptured Thin Films with Chiropterous Flavor", Prof. Lakhtakia, The Pennsylvania State University, University Park, PA, USA.

The program covered all relevant aspects of the research on complex media, that ranges from microwaves to X-rays. It underlines that there is still a strong need for basic understanding of complex media. This includes the exploration of both fundamental limits and the generic interaction with electromagnetic waves. The wealth of new (bianisotropic) material structures that are constantly proposed requires the development of adequate tools for the characterisation of their properties and constitutive parameters. This subject, which constitutes a scientific topic of ever increasing importance, was approached in detail during the conference. The research on complex materials has been largely stimulated and is still strongly driven by the questions raised in crystallography. Many contributions were devoted to this matter, one even dealing with the measurement of gyrotropy at X-rays. Artificial crystals for optical applications constitute one of the hot topics of current material research because of the many interesting applications that have been demonstrated or, at least, are within reach. One of the foci of the experimental sessions were new or improved techniques for the characterisation of chiral media, but also results of broadband measurements for the verification of theoretical approaches. Despite the progress that could be observed here, much work remains to do until useful applications of these very promising materials emerge at microwaves.

The panel discussion was centred around the question on the results and the perspectives of the research on complex materials. Unanimously, the gain in basic knowledge was considered to be a major benefit from the past and a potential for future research. The question raised was also closely related to possible applications of such materials. This, in turn, is also connected in fundamental as well as in technological and economical respects to the possibility to actually manufacture these media. Although the early optimism has diminished the representants of industry among the panel member encouraged the community to continue their research and, in particular, to intensify the experimental efforts. Further, the importance of the interdisciplinary dialogue between theoreticians and experimentalists in academia and industry was stressed.

Arne F. Jacob

# 14TH INTERNATIONAL WROCLAW SYMPOSIUM ON ELECTROMAGNETIC COMPATIBILITY

Wroclaw, Poland, 23-25 June 1998

The 14th Wroclaw Symposium on Electromagnetic Compatibility (EMC) gathered 355 participants from 43 countries. They met at University of Technology in Wroclaw (Poland) from 23 to 25 June 1998 to discuss various issues addressed in 143 papers published in the Proceedings. Organisational details are given in a separate Report by Mr. W. Moron', Organising Chairman, and will not be repeated here (his report is available also via Internet at [www.emc98.wroc.pl](http://www.emc98.wroc.pl)).

The symposium program covered a blend of theoretical and practical issues. EMC was understood in its wide sense as ability of a device, equipment, or system to function satisfactorily in its electromagnetic environment without introducing intolerable disturbances to that environment. This included spectrum congestion. The eight hundred pages of the Proceedings available at the opening presented a sample of current works at universities, in industry and in major international organisations involved. Plenary lectures and invited sessions created the nucleus of the Symposium. They were complemented by workshops, expositions and spontaneous contributions.

## Plenary lectures

There were four invited plenary lectures covering important problems of current interest.

Dr. R.L. Gardner, V-Chairman of URSI-E, addressed the issue of possible dangerous uses of electromagnetic energy, or "Electromagnetic terrorism", a real threat in the society that depends on telecommunications and computers. Until recently, that issue has been rather ignored. That problem will grow in significance, as our society is going to be more and more depending on the information technologies. Scientists, engineers, and the public should be aware of it.

Another important issue of wide interest was the impact of the World Radiocommunication Conference 1997 (WRC97). That issue was addressed by Mr. T. Boe, Member of ITU Radio Regulation Board. WRC97 cleared the way for truly global communication systems using low-earth orbiting satellite constellations and high-altitude-platform systems. Soon, such systems will offer access to global telecommunication network anywhere, anytime, at an affordable cost, one expects. It will change dramatically the way we live and do business and scientific research. The lecture was complemented by a workshop and spontaneous contributions (see the following sections for details).

Mr. K. Rosenbrock, Director General of ETSI, discussed the standardisation aspects of such wireless global systems. Among these systems, ERMES (Enchanted Radio Message System) is a high speed paging system with international roaming ability. Global System for Mobile communication (GSM) is entering its next phase of development, leading to the third-generation wireless

telecommunication systems such as the Universal Mobile Telecommunications Systems (UMTS). His lecture was complemented by a series of workshops devoted to standardisation (see the following sections for details).

The quality of electric power, another issue of basic importance for all electronic and electrical systems, was addressed by Mr. G. Goldberg, Immediate Past-Chairman of IEC Advisory Committee on EMC. Dips and voltage interruptions are the most unacceptable disturbances for the users, leading to blackouts, breakdown medical equipment, loss of production, etc. From the viewpoint of the utilities, however, the harmonics problem gives rise to more concerns.

## Invited sessions

There were ten invited sessions, three sponsored by URSI Commission E.

Prof. M. Hayakawa, Chairman of URSI-E, reviewed in his session the progress made in studies of terrestrial electromagnetic environment. Its five papers covered a wide range of atmospheric/ magnetospheric/ ionospheric radio noise. Terrestrial radio noise consists of a stationary background and a non-stationary component. The background seems to be associated with the global warming. The non-stationary component (ELF transients) come from newly found cloud-to-ionosphere discharges. Paper on laser-triggered lightning experiment was also an interesting contribution. Prof. Hayakawa recommended to organise similar URSI-sponsored sessions in future. He stated, among others: "...Wroclaw is the only place to accept this kind of session, except URSI General Assembly..."

Prof. T. Yoshino of Fukui University reviewed in his session the progress made in studies of electromagnetic field associated with earthquakes and volcanic eruptions. EM emissions registered at the satellite board could be used to monitor continuously underground faults in the Earth's crust and lithosphere dynamics. Cross-modulation phenomena associated with an earthquake (Japan, 19 Dec. 1997) were reported for the first time in the world. If confirmed, implications of these findings could be enormous. New experimental evidence for theoretical models could be produced and the earthquakes could be predicted. Several years ago, I encouraged Prof. Yoshino to address that topic at the Wroclaw symposium and we could note a continuing progress.

Prof. H. Kikuchi, Past-Chairman of URSI-E, devoted his session to EMC considerations of radiating structures. Included were studies of relations between the Zenneck, Sommerfeld, Goubeau, Casson-Pollaczek and K-waves. As usual, the selection of authors and quality papers was excellent.

Dr. J. Finnie of UK Radiocommunication Agency organised a session on major factors and methods in radio

frequency assignment. Radio propagation models, mathematical methods and computing tools were discussed. New trends in computer applications to frequency management were discussed at a session organised by Dr. T. Cesky of European Radiocommunication Office.

Dr. Th. Spoelstra, Secretary of CRAF, addressed in his session problems of co-existence of passive and active radio services after the year 2000 when new communication technologies and systems will operate. He also introduced a last minute information about the case of the TEX satellite - an example of wrong use of the radio frequency spectrum resource. After its mission was terminated in 1991, the satellite jammed radio astronomical observations at the 322 MHz band worldwide and it took several years to identify it finally in 1998. As it has no switch-off capability, it will continue radiating also in the future. These sessions were related closely to the activities of ITU and URSI WG on Spectrum Management and Wireless Telecommunications. They were complemented by specialised workshops and spontaneous contributions (see the following sections for details).

Prof. A. Karwowski (Poland) organised a session on computational methods of high-frequency electromagnetic fields with applications to personal communications. Prof. J. Catrysse (Belgium) organised a session on architectural shielding and Prof. H. Trzaska (Poland) - a session on EMC in radio amateur service. These sessions addressed issues of growing importance, in view of continuously increasing number of various radiating apparatus operating in dwelling houses, apartments and in immediate vicinity of human body.

A session and panel discussion sponsored by the NATO Expert Group on Electromagnetic Environmental Effects was organised by Mr. R. Azzarone (Italy) and Mr. A. Simi and Mr. S. Beaton (Belgium/ NATO). It reflected new trends in Europe, after the Cold War terminated.

### Regular sessions

Spontaneous papers were organised in regular and poster sessions. They complemented the invited lectures, sessions, workshops and panel discussions. There is not enough space here to discuss details and only session titles are mentioned.

- EMC in Power Systems (chaired by Mr. G. Goldberg, Switzerland)
- EMC Measurements and Instrumentation - I (chaired by Dr. D. Hansen, Germany)
- EMC Measurements and Instrumentation - II (chaired by Mr. P. J. Kerry, UK)
- EMC Prediction, Analysis, Modelling - I (chaired by Dr. J. Kelly, Ireland)
- EMC Prediction, Analysis, Modelling - II (chaired by Prof. K. H. Gonschorek, Germany)
- EMI Sources and Coupling Path to Victims (chaired by Mr. B. Despres, France)
- EMI Reduction Techniques (chaired by Mr. G. Kunkel, USA)
- ESD, Lightning, EMP (chaired by Prof. C. Mazzetti, Italy)

- Immunity (chaired by Prof. J. Kolodziejcki, Poland)
- Spectrum Management, Engineering, Sharing and Monitoring (chaired by Mr. R. Mayher, USA).

### Poster sessions

The three days of the symposium meant that the number of contributions that could be presented orally was limited. Poster sessions were organised to allow introduction of a greater number of interesting contributions. The following ten poster sessions were organised.

- Antennas and Propagation, EMC Aspects
- Biological Effects of EM Radiation
- EMC Related to PCB and IC
- EMC in Telecommunication
- EMC Measurements and Instrumentation
- EMC Prediction, Analysis, Modelling
- EMI Reduction Techniques
- ESD, Lightning, EMP
- Natural and Man-Made EM Environment
- Spectrum Management.

### Workshops

The program included few workshops that complemented nicely the main stream of the symposium.

A workshop that stemmed from discussions at the URSI General Assembly, Lille 1996 was organised by Dr. J. Finnie of UK Radiocommunication Agency, Dr. R. Leese of University of Oxford, and by myself. It was in the framework of the activities of the WG on Spectrum Management and Wireless Telecommunications co-chaired by Mr. G. Hurt (USA) and me. The workshop addressed new mathematical methods and tools used to relieve wireless communications from spectrum congestion problems. It gathered those interested in applied mathematics on the one hand, and those interested in solving practical problems of spectrum management on the other hand. A group of young mathematicians presented recent results obtained in seven Universities. That work was co-ordinated and supported by the UK Radiocommunications Agency. The contributions were based on the material presented at the meeting "Methods and Algorithms for Radio Channel Assignment" organised by Dr. Leese at University of Oxford on 8-10 April 1997. That material is to be published by the Oxford University Press in a book edited by Dr. Leese.

Mr. H. Kimball, Immediate Past-Chairman of ITU Study Group on Scientific Services, organised a workshop on EMC aspects of newly proposed wireless systems. The speakers presented the leading global projects: Teledesic, Sky Station, Orbcomm and Iridium and their problems. His workshop was entitled "New Era of Communications Technologies; EMC Aspects".

There was an official ITU workshop on electronic notification and access to the ITU databases organised by Mr. M. Giroux of ITU-BR, a special event associated with the symposium. Mr. R. Jones, Director of ITU Radiocommunication Bureau, opened the workshop and welcomed the delegates from Administrations, together with the representative of the host Administration.

Problems raised by the European EMC Directives were discussed at workshop "European Union EMC Directive in Practice", organised by Mr. M.C. Vrolijk, V-President of CISPR and Chairman of CENELEC SC210A EMC. Similar problems, but concerning the future standardisation work, was discussed at workshop "EMC Quo Vadis - What Standards Will We Need in The Future" organised jointly by Mr. P. Kerry, President of IEC-CISPR and Dr. B. Szentkuti, Chairman of IEC-TC77 EMC. These workshops were of vital importance for industry located in Europe and that interested in the European market.

Transient immunity tests, flicker and harmonics measurements on power line ports were presented at a workshop by Mr. M. Lutz (EMC PARTNER AG, Switzerland). Hewlett Packard (UK) entitled his workshop "EMC from Hewlett Packard". Penetration of EM field through shielding materials and components was addressed at a workshop organised by Mr. G. M. Kunkel (SPIRA Manufacturing Corp., USA).

### Expositions

An exposition of the equipment and systems, and exhibition of technical literature complemented nicely the symposium program. Technical exhibition enjoyed the participation of 15 companies. The exhibition of literature was organised with specialised publications of international organisations such as URSI, ITU, ETSI, EBU, CENELEC, CISPR, IEC etc. Besides some books on EMC, spectrum management and electromagnetics, other editions such as ITEM, Global Communications, or Microwave News, were shown. The exhibition was well received and well attended.

### Social events

On the evening of the first day, all participants were invited to a cocktail reception held in historical rooms of the City Hall. The XIII-century gothic architecture of the Hall, reconstructed with great care from ruins after the Second World's War, the excellent performance of the local Opera Quintet, and fine food created a friendly atmosphere. That mood was reinforced during the picnic organised the next evening outside the city of Wroclaw, with impressive firework dances symbolising the fight between the Right and Wrong. The last evening, after the final evaluation meeting, the Session Chairmen, and members of the Symposium Council, Scientific Program Committee and Organising Committee, were invited to reception offered by the Patron of the symposium, His Excellency Minister M. Zdrojewski. A wide selection of post-symposium tours

was offered after the symposium, including visits to Old City of Cracov and nearby Old Salt Mines and Museum of Auschwitz, all classified as first-class monuments in the UNESCO's registry of World Heritage sites.

### Final evaluation meeting

On the last day of the symposium, the common meeting of the Symposium Council, the Scientific Program Committee, Session Chairmen and the Organising Committee was held. It was jointly chaired by Dr. M. Rusin, V-Chairman of the Symposium Council and Deputy Minister of PTT, Poland, and by myself as Chairman of the Scientific Program Committee. The meeting positively evaluated the Symposium and its program, assuring a balanced coverage of low- and high frequency issues. The majority opinion was that the broad range of the Symposium topics mixing theoretical and practical topics should be retained. Contacts among scientists, engineers and managers involved in various fields of EMC were very fruitful. The positive influence of interaction between those involved in theory, and those involved in the engineering practice, cannot be overestimated. More scientific atmosphere of this Symposium in contrast with more commercially oriented EMC events was praised. Praised was also Young Scientists Program, organised with the financial support of URSI, thanks to which scientists from Belarus, Brazil, China, Georgia, Russia and Turkey could participate. The computer network with direct connection to Internet, made available free of charge to all participants, was complimented, too.

The Wroclaw EMC Symposium was first held in 1972, when there was no regular conference on that topic in Europe. Three years later, I invited Professor F.L. Stumpers, URSI Vice-President and Chairman of Commission E, kindly agreed to chair its Scientific Program Committee. At that time, when I visited him at his home in Eindhoven, none of us expected that it was the commencement of long-lasting intellectual adventure and personal friendship. He continued his leadership for over a quarter of century, gathering the most prominent EMC personalities around. Prof. Stumpers, with few enthusiastic friends, made the Wroclaw EMC Symposium Series one of the most successful international EMC gatherings. Since the very beginning, it has been a co-operative project, enjoying global interest evidenced by extended co-operations and the number and quality of contributions. The 1998 symposium confirmed that EMC is an exciting field of research, of great importance for a smooth entering in the era of Information Society.

R. Struzak



# REPORT OF THE 32<sup>ND</sup> COSPAR COUNCIL MEETING

Nagoya, Japan, 12-19 July 1998

The 32<sup>nd</sup> COSPAR Scientific Meeting was held in Nagoya Congress Centre, Nagoya, Japan from July 12, 1998 to July 19. Since I attended the COSPAR Council Meetings which were held in July 12th and 19th on behalf of Dr. J. P. V. Baptista, who is an official URSI representative for COSPAR, I would like to report the progress of the Council Meetings.

1. Activity report for the period since the 1996 COSPAR Scientific Assembly (omitted).

2. Presidential, Vice-Presidential, Remaining Bureau and Finance Committee elections

A report was made on the election roster worked out by the Nomination Committee. The results of the elections are as follows;

- President Prof. G. Haerendel (Germany)
- Vice-President (2 officers to be elected) Dr. L. J. Lanzerotti (USA) Prof. A. Nishida (Japan)
- Remaining Bureau (6 officers to be elected) Dr. J. Andersen (IAU) Dr. J. Audouze (France) Prof. A. Boyarchuk (Russia) Dr. G. Horneck (Germany) Prof. K. Kasturirangan (India) Dr. A. P. Willmore (UK)
- Finance Committee Chair Dr. F. Mariani (Italy)
- Finance Committee Dr. M. Rycroft (UK)

The voting method is a little bit different from the URSI Co-ordination Committee. Several COSPAR officers including myself felt some embarrassment. Their voting procedure for the election of COSPAR officers says as follows; "Only crossing out of names is authorised. All other modifications to ballot cards render them invalid. Candidates whose names are left unmarked will be considered to have received a "yes" vote. Candidates whose names are crossed out will be considered to have received a "no" vote. Since the secretariat explained that the "crossing" meant to horizontally make line on the unwanted candidate names, not make cross symbol on the name, we finally understood the way of voting.

3. Nomination Committee elections

The Council elected a Nomination Committee consisting of 5 members. The member of the COSPAR 1998 Nomination Committee was as follows; J. Geiss (Switzerland), J. P. Legos (Belgium), M. Machado (Argentina), R. A. Sunyaev (Russia), and L. Townsend (USA)

4. Financial report (part I) (omitted)

5. COSPAR Associated Supporters

In 1996 the Council voted to create a new category of COSPAR affiliates called "Supporters". Changes to the Charter and bylaws were drafted and submitted by correspondence to the Council for a vote. The Council was informed of the results of this vote and asked to approve a scheme for Associated Supporters categories and contributions. The council approved to create a new category of COSPAR affiliates called "Supporters".

6. 33<sup>rd</sup> COSPAR Scientific Assembly (COSPAR 2000)

The Council formally accepted the invitation of the Polish Academy of Sciences to meet in Warsaw at the 1996 Assembly.

- Report on Warsaw facilities was presented.
- Proposal for the 2000 registration fee was as follows; 1. Normal(early)—Euro 320, 2. Late—Euro365, 3. Student—Euro 110, 4. Accompanying person—Euro75. For each participant registered under category 1 and 2, COSPAR receives Euro 182.
- Proposal for the 2000 program chair was approved; Prof. Kazimierz Stepien (Warsaw University Observatory)

7. Future COSPAR Scientific Assembly

- 2002: The Council updated on planning for the 2<sup>nd</sup> World Space Congress in Houston, Texas, USA on October 11-20, 2002, in particular arrangements for a Joint Program Committee between COSPAR and IAF that will begin work creating a truly unified program as of this year.
- 2004: Taiwan, China, and Austria were volunteers for the 2004 COSPAR Scientific Assembly.

8. Chairs of COSPAR Commissions/Panels

Officers elected/re-elected or appointed/re-appointed in 1998 are newly added in the list of Scientific Commission/ Panel Officers.

9. Financial report (part II)

Internal Decision was made as follows; COSPAR approves the financial statements on the execution of the 1996 and 1997 budgets as presented at the first Council session of the 32<sup>nd</sup> COSPAR Scientific Assembly, and noting that the budget for 1998 has been approved by the Bureau in conformity with the authorisation given to the Bureau by the Council, resolves that the draft budget for 1999 be accepted as the provisional budget, and further the Council resolves that the Bureau be authorised to modify the 1998 budget as required to take into account changes agreed during the 32<sup>nd</sup> COSPAR General Assembly, or resulting from the financial transactions of this meeting, and that the Bureau be authorised to approve the final budgets for 1998 and 1999 as well as the draft budget for 2000 and the amounts of National Contributions for 2000, there being no Council meeting in 1999.

10. Resolutions and Recommendations

Resolutions and recommendations, as reviewed by the Drafting Committee, were approved by the Council.

11. Report on Commission business meetings

The chairs of the Scientific Commissions reported on Commission activities during the 32<sup>nd</sup> COSPAR Scientific Assembly.

12. Examination of proposed 2000 COSPAR Scientific Assembly events.

The Chair of the Program Committee for the 2000 Warsaw

Assembly, Prof. Kazimierz Stepien (Warsaw University Observatory), presented Preliminary 33<sup>rd</sup> COSPAR Scientific Assembly Event Proposals.

13. Proposals for future COSPAR Colloquia and other meetings with COSPAR involvement

- "The Outer Heliosphere: The Next Frontiers", after 2000 COSPAR Assembly, Toronto, Canada.
- "Space Weather Study Using Multi-point Techniques", in October 2000, Taipei, Taiwan.
- "Workshop on Satellite Data Reduction and Analysis Techniques", during November, 1999, Vienna, Austria.
- "Study of the Solar and Interplanetary Phenomena Associated with the Rising Portion of the Solar Cycle", July 25-27, 2000, Moscow, Russia.

- "The 3<sup>rd</sup> United Nations Conference on the Exploration and Peaceful Uses of Outer Space (UNISPACE III)", in July 12-30, 1999,

- "International Reference Ionosphere 1999 Workshop", August 9-12, 1999, Lowell, USA.

14. COSPAR publications

The Council was briefed on the current state of COSPAR publications in general.

COSPAR Information Bulletin (CIB)

- Advances in Space Research (ASR) Number of volumes published is 35. Number of volumes in press is 6. Estimated number of total volumes is 48.
- COSPAR Colloquia Series

Yoji Furuhashi

## MSMW'98

Kharkov, Ukraine, 15-17 September 1998

The third International Kharkov Symposium "Physics and Engineering of Millimetre and Sub-Millimetre Waves" (MSMW'98) took place in Kharkov State University, Kharkov, Ukraine on September 14-18, 1998. Working days of the symposium were September 15 to 17; September 14 was the day of registration, September 18 was filled with social events. Every day the conference started with a plenary session of 40-min invited lectures at a large auditorium. After it, four parallel day-long sessions of 20-min contributed papers had been working. All the papers were presented in English.

The number of registered participants was 148 including 92 from Ukraine; 17 from Russia, 8 from Germany, 2 from China, 1 from Great Britain, Japan, Belarus, Brazil, Mexico and Turkey, each. Totally 198 papers out of 247 in the Program were presented. Two-volume MSMW'98 Proceedings counting totally over 800 pages have been published before the conference. The holding of the conference became possible thanks to the support of sponsors. The next MSMW'2001 is planned to be held in Kharkov in 2001.

MSMW'98 started at 8:30 on September 15, 1998 by the opening ceremony at the "New Physical" auditorium of the Kharkov State University (KSU). First to address the participants was MSMW'98 Chairman, Director of the Institute of Radiophysics and Electronics of the National Academy of Sciences of Ukraine (IRE NASU), Vice-Chairman of the Ukrainian National URSI Committee Prof. Vladimir M. Yakovenko. He remarked that Kharkov symposia on millimetre and sub-millimetre waves have already 20 year history and have gained a high reputation and recognition in the Former Soviet Union (FSU) and world-wide. He was followed by the welcome words from MSMW'98 Co-Chairmen: Director of the Institute of Radio Astronomy of the National Academy of Sciences of Ukraine (IRA NASU), Vice-Chairman of the Ukrainian National URSI Committee Prof. Leonid M. Lytvynenko and Rector of Kharkov State University Prof. Vasiliy A. Svich. They

presented to the MSMW'98 participants main scientific developments of Kharkov radiophysicists. The next to make a welcoming speech was Vice-Head of Kharkov State Administration Dr. Valerij F. Mescheryakov. He told to the audience about the city of Kharkov, its historical and cultural heritage. Eventually, Prof. Alexander Nosich of IRE NASU addressed the participants on behalf of the IEEE East Ukraine Joint Chapter of the Antennas & Propagation, Microwave Theory & Techniques, Electron Devices, and Aerospace & Electronic Systems Societies. On the same morning the first plenary session was held, consisting of three invited talks:

- H-G. Unger\*, M. Shaahabadi, and K. Schuenemann\*\* "A Review of the Principles of Holographic Power Combining at Millimetre and Sub-Millimetre Frequency" (\*Institut fuer Hochfrequenztechnik, Technische Universität Braunschweig, Braunschweig, \*\* Technische Universität Hamburg-Harburg, Hamburg, Germany)
- R. Judaschke, K. Schuenemann "InP Transferred Electron Devices for Power Generation at Frequency about 130 GHz" (Technische Universität Hamburg-Harburg, Hamburg, Germany)
- V.M. Yakovenko "Transition Radiation of Charged Particles and the Possibility of Sub-millimetre Waves Generation in Plasma Like Media" (IRE NASU, Kharkov, Ukraine)

Further, after a coffee break, the conference continued working with four simultaneous sessions:

- B Electronics of MM and SUBMM waves, including quantum and relativistic electronics
- C Wave processes in finite-size semiconductors, solid-state structures and HTSC materials
- E MM and SUBMM wave propagation
- H MM and SUBMM devices based on the planar and quasi-optical transmission lines (passive and active components, antennas)

In this sessions, the following session invited papers were

presented:

- V.D. Naumenko\*, K. Schuenemann\*\*, V.Ye. Semenuta\*, D.M. Vavriv\*, V.A. Volkov\* "MM-Wave Transmitter Using Magnetrons with Cold Secondary-Emission Cathode" (\*IRA NASU, Kharkov, \*\* Technische Universität Hamburg-Harburg, Hamburg, Germany)
- B.G. Kutuza\*, G.K. Zagorin\*, A.Schroth\*\*, A. Hornbostel\*\* "Value Estimations of the Third Stokes-Vector Component Both Precipitation Microwave Emission and Sun Scattered Radiation Observations" (\*Institute of Radio Engineering and Electronics of Russian Academy of Sciences, Moscow, Russia, \*\*DLR, Deutsches Zentrum für Luft- und Raumfahrt, Institut für Hochfrequenztechnik, Oberpfaffenhofen, Germany)
- A.A. Kirilenko, L.A. Rud', V.I. Tkachenko, L.P. Mos'pan, D.Yu. Kulik "Integrated Software Package for Synthesis, Analysis and Optimisation of Frequency-Selective Devices of Millimetre and Centimetre Waves" (IRE NASU, Kharkov, Ukraine)

On same evening, at 7:30 p.m., Welcome Party was organised at the university cafeteria. Before it started, MSMW'98 participants were invited for a short visit to the roof out-looking space on top of the 14-level main tower of the university building. The September weather was fine and allowed enjoying aerial views of the 2-million city, full of green trees and busy streets. This event created a perfect atmosphere to relax and shake off the troubles of long and sometimes tiring journeys that participants had to undertake to reach MSMW'98

At the conference morning plenary session, the following invited papers were presented:

- Geoffrey Duxbury\*, Kevin Smith\*, Mark McPhail\*, Robert McPheat\*, John Ballard\*\*, and David Newnham, \*\* "The Synergy of Sub-millimetre and Infrared Spectroscopy in Predicting Global Warming Effects of CFC Replacement Molecules" (\*Department of Physics and Applied Physics, Glasgow, UK, Molecular Spectroscopy Facility, Rutherford Appleton Laboratory, Oxfordshire, UK)
- Peter Kordos "New Trends in GaAs-Based Devices for Generation of MM and SubMM Waves" (Institute of Thin Film Ion Technology, Research Centre Juelich, Juelich, Germany)
- K.A. Lukin "Millimeter Wave Noise Radar Technology" (IRE NASU, Kharkov, Ukraine)
- G.P. Kulemin "Remote Estimation of Soil Parameters by Radar Method" (IRE NASU, Kharkov, Ukraine)

This day regular sessions of contributed papers consisted of:

- A. New principles of generating and receiving MM and SUBMM waves
- D. Problems of the theory of wave diffraction
- F. Communications and radars; remote sensing
- L. Biomedical applications of MM and SUBMM waves

In the session F, session invited paper of E.P. Kropotkina, A.N. Lukin, S.B. Rozanov, S.V. Solomonov "Remote Sensing of the Atmospheric Ozone at Millimetre

Waves" (P.N. Lebedev Physical Institute of Russian Academy of Sciences, Moscow, Russia) was presented.

On the same evening, the conference banquet was held at the university cafeteria. This was a lovely event accompanied with live music, dancing and speeches. The dominant tone, however, was the joy of meeting the old friends and colleagues and making new ones.

On the third day, the morning session looked as follows:

- L.V. Lubyako, E.V. Suvorov, A.V. Burov, A.M. Shtanuk, Yu.A. Dryagin, L.M. Kukin, N.K. Skalyga "Detection Systems for the Measurement of Collective Thomson Scattering in Fusion Plasmas" (Institute of Applied Physics of Russian Academy of Sciences, Nizhny Novgorod, Russia)
- V.N. Balabanov, E.M. Ganapolskij, A.V. Golik, V.M. Efimov, A.P. Korolyuk, A.C. Kurekin, A.G. Sergeev, V.V. Tarakanov, and V.N. Tsymbal "Hypersonic Delay Lines: Physical Base, Technology and Using in the Space Radar Engineering" (IRE NASU, Kharkov, Ukraine)

Parallel sessions of regular papers that day went along the following topics:

- G. MM and SUBMM wave radio astronomy
- I. MM and SUBMM wave spectroscopy
- J. MM and SUBMM wavelength instrument-making for scientific research (hot-plasma diagnostics, control of technological processes)
- K. Electromagnetic metrology

In this sessions, following session invited papers were presented:

- V.M. Shulga\*, I.I. Zinchenko\*\* "Millimetre and Sub-Millimetre Wave Spectroscopy of Interstellar Medium" (\*IRANASU, Kharkov, Ukraine, \*\*Institute of Applied Physics of Russian Academy of Sciences., Nizhny Novgorod, Russia)
- B.A. Rozanov\*, S.B. Rozanov\*\* "Low-Noise Millimetre and Sub-Millimetre Wave Receivers" (\*Moscow State Technical Universitet, Moscow, Russia, \*\*P.N. Lebedev Physical Institute of Russian Academy of Sciences, Moscow, Russia)
- A.F. Krupnov, M.Yu. Tretyakov, V.N. Markov, E.N. Karyakin, G.Yu. Golubyatnikov, V.V. Parshin S.A. Volokhov, A.M. Shitov, V.V. Bichkov, I.I. Leonov "Precise Measurement in MM and Sub-MM-Wave Range Based on Phase-Locked Primary Radiation" (Institute of Applied Physics of Russian Academy of Sciences, Nizhny Novgorod, Russia)
- V.V. Meriakri "Materials Properties in Near Millimetre Wave Range" (Institute of Radio Engineering and Electronics of Russian Academy of Sciences, Fryazino, Moscow Region, Russia)
- Yu. V. Bykov, A.G. Ereemeev, V.V. Holoptsev, K.I. Rybakov, V.E. Semenov "Processing of Materials Using Millimetre-Wave Radiation" (Institute of Applied Physics of Russian Academy of Sciences, Nizhny Novgorod, Russia)
- M. Wollitzer\*, J. Buechler\*, J.-F. Luy\*\*, U. Siart\*, and J. Detlefsen\*\* "MM wave Radar Sensor for Vehicle

Applications" (\*Diemler-Benz Forschung Ulm, Ulm, Germany \*\*Lehrstuhl für Mikrowellentechnik, Technische Universität München, München, Germany)

- A.S. Kleiman "The Elaboration Measurement Accuracy Problems of the Frequency Characteristics of the Sources of High Stability Oscillations in the Millimetre and Sub-millimetre Range and of the Means of their Traceability" State Scientific-Industrial Association "Metrology", Kharkov, Ukraine)

The closing ceremony of MSMW'98 took place in the "New Physical" auditorium of KSU at 5:30 p.m. At first, several awards of the conference were announced and handed to the awardees.

Eight MSMW'98 awards "In recognition of remarkable presentation at the young scientists paper competition" went to the following young scientists:

- Rolf Judaschke (Technische Universität Hamburg-Harburg, Hamburg, Germany)
- Michael Wollitzer (Daemler-Benz Forschung Ulm, Ulm, Germany)
- Koki Watanabe (Kyushu University, Fukuoka, Japan)
- Alexander Zamyatin (Moscow Institute of Physics and Technology, Dolgoprudnyi, Moscow Region, Russia)
- Kirill Rybakov (Institute of Applied Physics of Russian Academy of Sciences, Nizhny Novgorod, Russia)
- Vladimir Tkachenko (KSU, Kharkov, Ukraine)
- Andrey Serebryannikov (IRA NASU, Kharkov, Ukraine)
- Andrey Andrenko (IRE NASU Kharkov, Ukraine)

Each MSMW'98 award consisted of a colourful certificate signed by the MSMW'98 Chairman and a bottle of Crimean champagne.

Final closing address was done by Prof. Vladimir M. Yakovenko. He informed the audience that, in all, the number of registered participants was 147. Unidentified number of non-registered participants was estimated as around 50, mainly from Kharkov universities and research establishments. Of 247 papers included into the MSMW'98 Program, 205 had been presented according to the preliminary information.

One should note that such a support, as well as publishing the Program and the 800-page Proceedings, and holding such a conference in general would not be possible without a generous support of MSMW'98 sponsors: URSI, IEEE ED and MTT Societies, US Army European Research Office, Science and Technology Centre in Ukraine

In particular, the contribution of URSI (Commissions F and K) was in the amount of \$1,500. This money was used to support the participation of the following speakers:

1. H.C.C. Fernandes (Rio Grande do Norte, Brazil) - \$400
2. M. Wollitzer (Ulm, Germany) - \$250
3. F. Dikmen (Gebz-Kcaeli, Turkey) - \$200
4. V.F. Kravchenko (Moscow, Russia) - \$50
5. B.G. Kutuza (Moscow, Russia) - \$50
6. V.V. Meriakri (Moscow, Russia) - \$50
7. B.A. Rozanov (Moscow, Russia) - \$50
8. S.B. Rozanov (Moscow, Russia) - \$50
9. V.V. Torchinov (Moscow, Russia) - \$50
10. A.A. Zamyatin (Moscow, Russia) - \$50
11. Yu.Yu. Kulikov (Nizhny Novgorod, Russia) - \$50
12. L.V. Lubyako (Nizhny Novgorod, Russia) - \$50
13. M.M. Ofitserov (Nizhny Novgorod, Russia) - \$50
14. K.I. Rybakov (Nizhny Novgorod, Russia) - \$50
15. A.A. Shvetsov (Nizhny Novgorod, Russia) - \$50
16. M.Yu. Tretyakov (Nizhny Novgorod, Russia) - \$50

After that, Vladimir M. Yakovenko announced that the next Symposium, MSMW'2001, will be held most probably again in Kharkov in 2001, thanked the organisers for creating an unprecedented forum for scientific discussions and expressed a hope that MSMW series will continue.

After closing of the MSMW'98, the participants were proposed a dense social program in order to get relaxed after three days of intensive work and strengthen the links originated at the symposium. On Friday, September 18, a field trip was organised to the UTR-2 Observatory of the IRA NASU. This world-largest decametre wavelength radio telescope is located about 80km southwards from Kharkov. After visiting radio telescope a barbecue party was held.

VI. Yakovenko & A.A. Kostenko

## WAVE PROPAGATION AND REMOTE SENSING

Aveiro, Portugal, 22-25 September 1998

URSI Commission F, the 8<sup>th</sup> International Triennial Open Symposium was held from September 22 to 25, 1998, at the Congress Center, Aveiro, Portugal, organized by URSI Commission F with the support of Portugal Telecom, Fundacao para a Ciencia e Tecnologia, Fundacao Calouste Gulbenkian, Fundacao Luso Americana para o Desenvolvimento, Instituto de Comunicacoes de Portugal and Instituto de Telecomunicacoes (Polo de Aveiro).

The Open Symposium has been a series of an inter-General Assembly meeting of Commission F designed to exchange scientific information and views about radio

wave propagation and remote sensing. It is usually held one year before every URSI General Assembly. Early symposia in this series were held in La Baule, France (1977), Lennoxville, Canada (1980), Louvain-la-Neuve, Belgium (1983), Durham, USA (1986), La Londe-les-Maures, France (1989), Ravenscar, UK (1992), and Ahmedabad, India (1995).

The Open Symposium was organized by the Organizing Committee which consists of Prof. A. C. D. Rocha (Chair), Dr. Y. Furuhashi, Dr. J. P. V. Poiras Baptista, Prof. J. C. S. Neves, Ms. Adelaide Costa and Mr.



A. Marques. The Scientific Programme Committee consists of Dr. Y. Furuhashi (Chair, Vice-Chair Commission F), Mr. M. P. M. Hall (Chair, Commission F), Dr. J. P. V. Pórigues Baptista, Prof. Armando Fiuza, Prof. M. Hallikainen, Prof. Richard K Moore, Prof. J. C. S. Neves, Dr. K. Okamoto, Dr. R. L. Olsen and Dr. W. J. Vogel.

The Symposium was attended by 70 participants from 22 different countries. The number of participants from UK was the largest with 10, followed by the Japan with 9, the Italy and USA with 8, Brazil, Canada and the Netherlands with 5. A total of 66 papers from 17 different countries were presented in the Symposium. 47 papers were presented orally in the eight sessions and 19 papers were presented as posters. All sessions were held not in parallel, but in sequential. The session names with oral (poster) paper numbers are as follows:

- Propagation on Earth-Space (2 sessions) with 15 (8) papers
- Propagation on Terrestrial Paths with 7 (5) papers
- Mobile Propagation with 5 (1) papers
- Remote Sensing of Surfaces 3 (3) papers
- Remote Sensing of Rain and Hydrometeors 9 (0) papers
- Radio Meteorology and Climatic Parameters 4 (0) papers
- Remote Sensing of Atmosphere 4 (2) papers.

Every morning one invited paper was presented. Prof. Peter A. Watson presented a talk on the recent advances of rain fading studies in tropical areas, focusing on those in Malaysia. Prof. Jun Awaka presented new results derived from the data obtained by the Precipitation Radar on the TRMM (Tropical Rainfall Measuring Mission) satellite. This satellite was successfully launched in November, 1997 to clarify the role of tropical precipitation in the global hydrological and energy cycle. Dr. Peter H. Hildebrand talked on the recent advances of atmospheric dynamics from a radiometeorological aspect. Dr. Wolfhard J. Vogel gave a presentation on the satellite diversity fade measurements for mobile satellite communication systems.

A symposium excursion to a sandbank located one hour distance from Aveiro by boat, where border on the Antarctic ocean and inland sea, was made in the afternoon of the 3<sup>rd</sup> day. We enjoyed symposium banquet in the restaurant on the sandbank.

In the relatively small scale symposium for 4 days, almost all the participants became friend each other and therefore the symposium was quite successful. We owed these successes deeply to the efforts of the member of the local Organizing Committee headed by Prof. Armando Rocha. Here I would like to express my sincere thanks to them for their heartfelt dedication.

Yoji Furuhashi

## JINA 98

Nice, France, 17-19 November 1998

The 10<sup>th</sup> International Symposium on Antennas, "Journées Internationales de Nice sur les Antennes", was held at Palais des Congrès Acropolis from 17 to 19 November 1998. The JINA were created in 1982, initiated by CNET, France Télécom R&D Centre, Antennas Department in La Turbie, Mobile Services and Radio Systems Division, with the support of the Scientific Direction, the active contribution of the "Société des Electriciens et des Electroniciens, Groupe Régional Côte-d'Azur" (SEE-GRÉCA), of the University of Nice - Sophia Antipolis, Electronics, Antennas and Telecommunications Laboratory, and thanks to the voluntary assistance of the expert members of the international Scientific Committee. They are morally sponsored by SEE, URSI and IEEE Antennas and Propagation Society.

Since 1984, the JINA are organized as a biannual event, a real and unique international forum for the specialists in antennas who come to focus on the new needs as well as the technical and technological advances where innovation is a fundamental factor. They remain the privileged place for meeting and exchange between academy and industry, in a particularly cordial atmosphere, studious and convivial at the same time. The main characteristic of this symposium is its partition into six half-day non parallel sessions, with invited conferences in the Hermes auditorium (with simultaneous French-English translation) and poster presentations in the large Rhodes area, the whole stimulating

fruitful contacts and the valorization of R & D. An original decoration had been put in place especially for this 10<sup>th</sup> edition. Stands for presentation of software products, including CNET's, were present.

It has been literally a week on antennas that took place in Nice. As the members of the European action COST 260 Smart Antennas were meeting on place just before, a workshop Electromagnetism was organized independently, the day following JINA. More military applications were dealt with in the specific session "Radar Cross Section". Exceptionally, the "9<sup>th</sup> European Electromagnetic Structures Conference - EESC'98" joined JINA 98 in the frame of a special session "Radomes". For the first time, in connection with "electromagnetic ecology", an eminent biophysicist, professor Miro, was invited to present the state of studies about the possible biological action of cellular phones.

Antennas constitute a key element in the implication, still stronger and more complex, of radio in telecommunications, the progression of which is exponential: fabulous growth of the mobiles and preparation of the generations to come, large bandwidth distribution, terrestrial or by satellite, for the internet and multimedia, where the radio solution towards higher frequencies can provide flexibility and competitiveness. Spatial diversity with smart and adaptive antennas in order to still increase the density of communications, and the control of diffraction

phenomena in urban environment, also constitute still more difficult challenges. Active elements and the direct integration of optics appear. Modeling tools come into general use, while being more and more sophisticated and spectacular, with a tendency towards hybridization of numerical methods (MM, PO, FDTD, FEM, UTD).

Thus it appears imperative that upstream and downstream R & D efforts of the various players progress in a coordinated manner. The JINA fit quite naturally into this action. This 1998 edition has been exceptional, with record figures : 211 paper submissions, from 33 countries, have been received, from which 157 accepted, published in the Proceedings. The number of participants has been 340. This confirms the interest and effervescence in the field, revealed again by the fact that the auditorium was still almost full at the end of the last half-day !

One must not neglect the importance of the surroundings : the Acropolis congress centre, the town of Nice and its area, the organization without fail, the sun

which appeared generous, the cocktail, and the gala dinner in the Cabaret of Casino de Monte-Carlo. Just after these memorable days, the colleagues who contributed voluntarily to their so great success went back with enthusiasm to their usual work, to prepare and develop the means of telecommunications of the future.

And for the next edition, JINA associates exceptionally with ICAP (International Conference on Antennas and Propagation, UK) for AP 2000 – Millennium Conference on Antennas & Propagation, in Davos, Switzerland, 9-14 April 2000 (<http://estec.esa.nl/AP2000/>).

### Contact

Raymond Bills

Secrétariat JINA 98

France Télécom/CNET/Fort de la Tête de Chien  
06320 La Turbie, France/Fax : +33 4 92 10 65 19

[jina.cnet@wanadoo.fr](mailto:jina.cnet@wanadoo.fr)

<http://wwwwelec.unice.fr/JINA-98/>

## 4TH EBEEA CONGRESS

Zagreb, Croatia, November 19-21, 1998

On November 19 to 21, 1998, the 4th Congress of the European Bioelectromagnetics Association (EBEA) was held in Zagreb, Croatia. Faculty of Electrical Engineering and Computing hosted approximately 200 visitors from all over the world, making this 4th Congress one of the most visited so far. The main issue of the Congress has been the research of the influence of the electromagnetic field radiation on human health. This is the reason the Congress gathered not only electric engineers, but medical doctors and biologists as well. The Commission (K) on Electromagnetics and Biology of URSI was co-sponsor of this Congress.

Prior to the 4th EBEEA Congress, on November 18, 1998, a World Health Organisation (WHO) Round Table on the world-wide harmonisation of the standardisation process in the field of bioelectromagnetics was held. The unification process has been initiated in Europe, but there are still differences in the approach in the interdisciplinary field of bioelectromagnetics in the East and West.

The following eminent scientists participated in WHO Round Table : Michael Repacholi (WHO), Juergen Bernhardt (IRPA / ICNIRP), Barnabas Kunsch (European CENELEC), Jon Klauenberg (NATO), John Leonowich (IEEE), Johannes Hohenberg (Austria), David Black (Australia & New Zealand), Michael Israel (Bulgaria), Art Thansandote (Canada), Dina Simunic (Croatia), Josef Hurych (Czech Republic), Robert Cleveland (FCC), Bernard Veyret (France), Olaf Schultz (Germany), Gyorgy Thuroczy (Hungary), McManus (Ireland), Paolo Vecchia (Italy), Chiyoji Ohkubo (Japan), James Lin (NCRP), Stanislaw Szmigielski (Poland), Nina Roubtsova (Russia), Youri Grigoriev (Russia), Peter Gajek (Slovenia), Mirjana Moser (Switzerland), Alastair McKinley (United Kingdom)

The 4th EBEEA program consisted of 9 sessions:

- Epidemiology and human health studies (13 presentations)
- Medical applications of EMF fields (15 presentations)
- In vitro studies (22 presentations)
- EBEEA/BEMS sessions on mobile phone effects (10 presentations)
- Dosimetry (18 presentations)
- In vivo studies (18 presentations)
- Instrumentation and measurements (4 presentations)
- Interaction mechanisms (12 presentations)
- Research and funding organisations (3 presentations)

Participants shared and discussed results of their work in either platform or poster sessions.

Papers in Epidemiology and Human Health Studies investigated the influence of electromagnetic radiation on the population (people who reside in the vicinity of the radar installations, high voltage power lines, or working population in the air traffic control industry). The session also provided an overview of possible discrepancies in the normal functions (EEG, bloodpressure, heart rate) of the exposed population. The Medical Applications of EMF Fields session searched for both positive or negative influences of the electromagnetic radiation on the human tissue. Positive influences are especially interesting in the field of orthopaedic, ablation and cancer treatments. Papers in the In Vitro Studies session explored effects of electromagnetic field exposure on human tissue (lymphocytes, liposomes, enzymes, plasma membrane) .

The EBEEA/BEMS session on Mobile Phone Effects studied the radiation effect of wireless communication equipment that operate at the mobile phone frequencies. The Dosimetry session examined the amounts of the

absorbed energy in the human tissue, for which numerical methods and measurements are required. The In Vivo Studies session reported studies on effects of electromagnetic radiation in animals with the view that these results may revealed insights into human health studies. The Instrumentation and Measurements session dealt with possible effects of the instruments and measurements at work in the user vicinity (MRI systems, Electromagnetic Field Meters, etc.). The Interaction Mechanisms session studied the interaction mechanisms between the RF radiation and the user.

During the Research and Funding Organisations session, several research and funding organisations dealing with the problem of electromagnetic field effects on human health were presented (projects, funding, programs, etc.).

Young scientist prizes were awarded for best presentations from among the scientific contribution received. The recipient for the best platform presentation is: Paola Russo, Dipartimento di Elettronica ed Automatica, Universit di Ancona, Italy for the report : "A New Hybrid Technique For Field Evaluation Inside a Biological Medium."

And for the poster competition is: Jurij Galvanovskis, Department of Medical Biophysics, Göteborg University, Sweden for the poster : "Periodic Forsing of Intracellular Calcium Oscillators."

In connection with the 4th EBEA Congress, the 6th COST 244bis MCM and 5th workshop were held. The main focus of this workshop was to review exposure assessments in epidemiological studies devoted to RF electromagnetic radiation and adverse health in humans. Six presentations addressed various aspects of this: Dr Kelsh, Prof. Szmigielski, Dr Hamnerius, Dr Hansson Mild, Dr Balzano and Dr Pontalti. In addition, two presentations (by Drs Brumen and Hietanen) addressed other issues. Overall strategy of exposure assessment in RF epidemiology studies - framework for future RF exposure assessment was were described as adequate for thermal processes - and as a best

candidate for dose and dose rate. In the discussion, the validity of RDI ("radiation dose index") as a dose concept was questioned, since it would have to assume far-field condition.

Instrumentation for RF field exposure assessment - some requirements for area determination of field levels have been stated. In contrast to instrumentation for area measurements, several practical problems (need for frequency specification, field coupling to the body) have so far hindered the development of reliable personal monitoring instruments. Other methods for RF exposure assessment - methods used in a number of retrospective occupational epidemiological studies to estimate exposure to RF were reviewed and categorisation of workers was described. Selection of exposure groups - the prior choice of probably exposed occupational groups may be an efficient way of establishing a cohort with valid contrast. Such selections have often been based on user groups (various military groups, air traffic and radar personnel, etc.). In other circumstance, such as mobile phone users, variations within the group may be too great to obtain reliable contrasts.

Exposure misclassification and sensitivity may not necessarily invalidate findings. Characteristics of the non-differential misclassification and uncertainty for what time period to obtain exposure assessment were discussed.

Review of exposure levels - overview of RF exposure in the general environment and various exposure situations for occupational settings, were given. A few other occupational settings have also been evaluated. Special considerations of mobile phone situations - various techniques have been developed to cope with problems in evaluation of the mobile phone - human head interaction (such as the use of small electrodes inside phantom heads). The numerical calculations approach was also discussed (canonical cases and realistic head shapes). A phone-based monitoring system, which could record several pieces of information about the phone's usage, was suggested.

Dina Simunic and James C. Lin

## CONFERENCE ANNOUNCEMENTS

### URSI/COSPAR

Lowell, Massachusetts, USA, 9-12 August 1999

The URSI/COSPAR Working Group on the International Reference Ionosphere (IRI) will hold its next annual meeting at the University of Massachusetts Lowell, USA, from August 9 to 12, 1999, i.e. in the week preceding the URSI General Assembly in Toronto, Canada.

These annual meetings are the primary venue for improvements and refinements of the IRI representation of ionospheric electron density, electron temperature, ion composition and ion temperatures.

The special emphasis of the 1999 Workshop will be on:

1. specification of the variability of ionospheric characteristics

2. the use of IRI for ray tracing studies and applications

Other topics of interest for the workshop include comparisons of IRI with measurements and with other models, suggested improvements and additions for IRI, and applications of the IRI model. Papers on new additions to IRI are especially welcome: strom-time model, ion drift

model, spread-F model, and plasmaspheric model. It is expected that the papers from this meeting will be published in *Advances in Space Research*.

Organising Committee : B. Reinisch (UML), X. Huang (UML), D. Bilitza (RITSS)

Programme Committee : B. Reinisch (USA), D. Bilitza (USA), K. Oyama (Japan), K. Rawer (Germany), P. Dyson (Australia), S. Radicella (Italy/Argentina), P. Bradley (U.K.), S. Pulnits (Russia)

Abstracts are due by March 15, 1999. Please include

title, author(s), address with Fax and e-mail and send by e-mail to [Donna\\_Milinazzo@uml.edu](mailto:Donna_Milinazzo@uml.edu). The length of the whole abstract should not be more than one page.

This announcement and future updates can be found at : [http://nssdc.gsfc.nasa.gov/space/model/ionos/iri/iri\\_99\\_ann.html](http://nssdc.gsfc.nasa.gov/space/model/ionos/iri/iri_99_ann.html). More information about the IRI project and past IRI workshops can be found at <http://nssdc.gsfc.nasa.gov/space/model/ionos/iri.html>. The Homepage of the Center for Atmospheric Research is at <http://ulcar.uml.edu>.

## RADIO AFRICA '99

Gaborone, Botswana, 25 - 29 October 1999

### Background

The Radiowave Propagation Research Network between Africa and Latin America was established in 1987 under the External Activities Programme of the International Centre for Theoretical Physics, Trieste, Italy. The Regional Workshop on Radio Communication is being held as part of the activities of the network in stimulating collaboration among African Scientists working in the area of radio communication and related fields.

The Regional Workshop on Radio Communication in Africa (or Radio Africa) is a biannual event. Radio Africa'95 was held at the Obafemi Awolowo University, Nigeria, in 1995; and Radio Africa'97 was held at the Kenya College of Communications Technology, Nairobi, Kenya, in 1997. One of the resolutions of the Radio Africa'97 Workshop was that the Third Regional Workshop in the series, Radio Africa'99, be in Gaborone, Botswana. The theme of the Workshop is "Rural Communications for Development in Africa."

### Objectives

The broad objectives of the Workshop are:

1. Highlight the advances in Radio Communication for the development of the continent.
2. Foster collaboration among African Scientists and researchers working in the area of Radio Communication.
3. Identify the need and formulate regional joint research projects cutting across national boundaries for the solution of Radio Communications problems in Africa and the world.
4. To consolidate the gains made in the previous two Workshops, and chart new operational, training and research agenda for the next millennium.
5. To share global experiences in Rural Communications for adaptation to the African context.

### Participation

The Workshop is open to Scientists working, researching, or training in the area of Telecommunications or related

fields from the public and private sectors. Postgraduate students are also welcome to attend. The official working language of the Workshop will be English. Tutorial Sessions will be conducted by specialists in radio Communication, and a separate fee US\$500 per person will be charged for those attending to cover for the tutorial materials.

### Topics

The topics for the Workshop include the following:

- Radio wave propagation
- Spectrum Management and Utilization
- Development and Trends in Mobile, Satellite, and Wireless Communications
- Television and Radio Broadcasting
- Remote Sensing
- Antennas and Feeder Systems
- Optical Fibre Communications
- Amateur Radio in Africa
- Electromagnetic Radiation Effects on the Environment.
- Liberalisation Trends & Effects in Telecommunications
- Training and Research in Telecommunications.
- Signal Processing
- Digital & Image Processing
- Microprocessor Applications for Communications
- Related Topics

### Deadlines

Submission of Abstracts : 1<sup>st</sup> February 1999

Acceptance Notification : 15<sup>th</sup> March 1999

Submission of Camera-Ready Manuscript : 1<sup>st</sup> July 1999

### Contact

Dr. Thomas Afullo  
The Secretariat, Radio Africa'99  
Faculty of Engineering & Technology,  
University of Botswana,  
Private Bag 0061, Gaborone, Botswana.  
Tel: +267-3554342, Fax: +267-352309  
E-mail: [afullotj@noka.ub.bw](mailto:afullotj@noka.ub.bw)



# URSI CONFERENCE CALENDAR

URSI cannot be held responsible for any errors contained in this list of meetings.

The Guidelines and Rules for URSI Sponsorship of Meetings can be found at <http://www.intec.rug.ac.be/ursi/Rules.html>

## March 1999

### 10th MICROCOLL

*Budapest, Hungary, 21-23 March 1999*

Contact : Ms. K. Lang & Mr. A. Varga, Diamond Congress Ltd. - Microcoll, Fo u. 68, H-1027 Budapest, Hungary, Tel. +36 1-214 7701, Fax +36 1-201 6383, E-mail : [diamond.eft@mtesz.hu](mailto:diamond.eft@mtesz.hu), <http://www.mtesz.hu/tagegy/diamond/eindex.htm>

## May 1999

### IWTS'99 - 1999 Int. Wireless and Telecommunications Symp./ Exhibition

*Shah Alam Malaysia, 17-21 May 1999*

Contact : Dr. Sathish Chandran, Perwira Ericsson Sdn. Bhd, Wisma Ericsson, Jalan SS7/19, Kelana Jaya, 47301 Petaling Jaya, Selangor D.E., MALAYSIA, Phone : +60-3-7087944, FAX : +60-3-7087919

## June 1999

### Day on Diffraction 99

*St. Petersburg, Russia, 1-4 June 1999*

Contact : Ivan Andronov or Valery Grikurov, Inst. on Physics, St. Petersburg University, Petrodvoretz 198904 Russia, Fax: +7-812-428-7240, E-mail : [grikurov@mph.phys.spbu.ru](mailto:grikurov@mph.phys.spbu.ru)

## July 1999

### IGARSS'99

*Hamburg, Germany, 28 June - 2 July 1999*

Contact : Ms. T.I. Stein, Director of Confernces and Information Services, Geoscience and Remoteensing Society, 2610 Lakeway Drive, TX 77586-1587 Sabrook, USA, Phone : +1 713-291-9222, Fax : +1 713-2-9224, E-MAIL : [TSTEIN@PHOENIX.NET](mailto:TSTEIN@PHOENIX.NET)

## August 1999

### Radio Methods for Studying Turbulence

*Urbana, Illinois, USA, 9-12 August 1999*

Contact : Prof. A. W. Wernik, Space Research Center, Polish Academy of Sciences, ul. Bartycka 18a, 00-716 Warsaw, Poland. Tel +48-22-403766 ext 379; fax +48-22-403131; email [aww@cbk.waw.pl](mailto:aww@cbk.waw.pl)

### International Reference Workshop 1999

*Massachusetts, Lowell, USA, 9-12 August 1999*

Contact : Prof. Bodo W. Reinisch, Center for Atmospheric Research, University of Massachusetts Lowell, 600 Suffolk Street, MA 01854 Lowell, USA, Phone : +1978-934 4903, Fax : +1 978-459 7915

### XXVIth URSI General Assembly

*Toronto, Canada, 13-21 August 1999*

Contact : URSI GA '99 Secretariat, National Research Council Canada, Ottawa, Ontario K1A 0R6, Canada, Tel. +1 613-993 7271, Fax +1 613-993 7250, E-mail : [ursi99@nrc.ca](mailto:ursi99@nrc.ca), <http://www.nrc.ca/confserv/ursi99/welcome.html>

## November 1999

### ICCEA'99

#### International Conference on Computational Electromagnetics and its Applications

*Beijing, China, 1-4 November 1999*

Contact : Mr. Meng-Qi Zhou, P.O. Box 165, Beijing 10036 China, fax +8610 6828-3458, E-mail : [mqzhou@public.bta.net.cn](mailto:mqzhou@public.bta.net.cn)

### The Universe at Low Radio Frequencies

*Pune, India, 30 November - 4 December 1999*

Contact : Prof. V.K. Kapahi, NCRA-TIFR, Pune 7, India, Tel. +91 212-35 5149, Fax +91 212-35 7257, E-mail [vijay@ncra.tifr.res.in](mailto:vijay@ncra.tifr.res.in)

## April 2000

### AP 2000

*Davos, Switzerland, 9-14 April 2000*

Contact : AP 2000, ESTEC Conference Bureau, Postbus 299, NL-2200 AG Noordwijk, The Netherlands, Tel: +31 71 565-5005, Fax: +31 71 565-5658, E-mail: [confburo@estec.esa.nl](mailto:confburo@estec.esa.nl)

## May 2000

### EUSAR 2000

*Munich, Germany, 23-25 May 2000*

Contact : Dr. W. Keydel, German Aerospace Center (DLR), Postfach 1116, D-82230 Wessling, Germany, Tel. +49 8153-28 2305, fax +49 8153-28 1335, E-mail: [eusar2000@dlr.de](mailto:eusar2000@dlr.de)

### EUROEM, EuroElectromagnetics

*Edinburgh, Scotland, UK, 30 May - 2 June 2000*

Contact : EUROEM 2000, Concorde Services Ltd., Suite 325, The Pentagon Centre, Washington Street, Glasgow G3 8AZ, Scotland, United Kingdom, Tel: +44-141-221-5411, Fax: +44-141-221-2411, E-mail: [euroem@concorde-uk.com](mailto:euroem@concorde-uk.com)

## August 2000

### ISAP 2000

*Fukuoka, Japan, 22-25 August 2000*

Contact : Dr. Yoshio Karasawa, ISAP 2000, KDD R&D Labs, Inc. 2-1-15 Ohara, Kamifukuoka-shi, Saitama 356-8502, Japan, Tel. +81 492-78 7327, Fax +81 492-78 7524, E-mail [karasawa@lab.kdd.co.jp](mailto:karasawa@lab.kdd.co.jp)

# News from the URSI Community

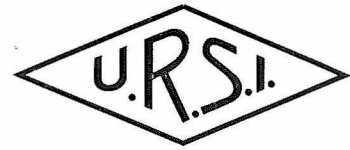

## OUR MEMORIES OF JIM WAIT

Edited by R. L. Dowden

*This is a collection of memories from young and old friends of Jim Wait. Each contribution is informally by-lined by the contributor. The first is an abridged version of an obituary (another appears elsewhere in this issue) being published in the IEEE AP-S Magazine. The last is by me. As editor of this collection, I wrote my piece after reading and editing the others.*

James Wait was born on January 23rd, 1924, in Canada's capital city, Ottawa, the son of an Air Vice Marshall, the highest officer rank in the Royal Canadian Air Force at that time. Many of his pre-high school years were spent with his parents in England. He completed his secondary schooling at Ashbury College in Rockcliffe, the site of an air force base and now Ottawa's secondary airport. It appears that he was not a good student in any subjects except Mathematics and Science and he had to be tutored in both Latin and Ancient History. In 1941 he enrolled at McGill University in Montreal but left in 1942 to join the Canadian Army for training as a radar technician. Jim later told me that he would have preferred to join the Royal Canadian Air Force but, in view of his father's exalted rank, thought it best to try the army instead, where he felt he would enjoy the opportunity to make it entirely on his own merit. When WWII ended in 1945 he was in charge of a radar maintenance unit in Kingston, Ontario.

Instead of returning to McGill University in Montreal, Jim chose the University of Toronto and enrolled in the Engineering Physics course in 1945. He graduated with the B.A.Sc. degree in 1948, went on to take his M.A.Sc. in 1949 and then became the first Ph. D. student of the late Professor George Sinclair, obtaining that degree in 1951.

It was during the years 1948 to 1951 that I first met and came to know Jim Wait quite well. At that time Dr. Arthur Brant of the Department of Geophysics (whom I had known in pre-war days) was occupied in setting up a company, Newmont Exploration Limited, in Jerome, Arizona, as a division of Newmont Mining Corporation of New York. At Dr. Brant's invitation, Jim spent at least two summers, including that of 1950, in Jerome doing theoretical work on induced polarization (IP) as a technique for geophysical prospecting. When Jim returned to Toronto in the fall of that year he was brimming with enthusiasm and anxious to complete his Ph. D. so that he could return to Jerome on a full time basis. His enthusiasm was the more understandable when he confessed that he had become

enamoured of a lovely young lady, Gertrude Norman, the daughter of a prominent Canadian geologist who was working in Jerome for Mingus Mountain Mining Company. Many years later, at a gathering of former Newmont Exploration colleagues at his home in Tucson, Jim jokingly told us how he had asked Gertrude's father, Dr. Norman, for permission to marry his daughter; all he got was a pat on the head and this bit of advice, "Finish up your Ph. D. young man, get a full time job and then come back"!

A little less than a year later, in the spring of 1951, Jim received the prized degree, accepted a full time job with Newmont Exploration and hastened back to Arizona. I got my degree that year also and I don't recall seeing Jim at the formal graduation ceremony on the campus; no doubt he had other things on his mind! James and Gertrude were married shortly after his arrival in Jerome, in June of that year.

Newmont Exploration rented various buildings from United Verde Exploration Company in a mining area of Jerome quaintly known as the "Little Daisy". There were also a couple of 2,000 foot mine shafts with A-frames intact but the hoists were no longer operable. Jerome, in fact, was becoming a ghost town as ore reserves began to yield less than 1% copper and were only to be found at very great depth. Jim worked on the theory of induced polarization in disseminated ore bodies and he also spent considerable time analyzing the raw data provided by the field crews.

For reasons that he never fully divulged to me, Jim left Newmont and Arizona and returned to Canada in, I believe, 1952. Perhaps there is a clue in a remark he made to me shortly before he left: "The earth is a conductor of electricity, the atmosphere is a dielectric and the ionosphere above it is another conductor. They form a waveguide and we can study this waveguide by solving Maxwell's equations, if only we apply the right boundary conditions." I think it likely that Jim wanted to do just that but realized that if he stayed with Newmont he would have to continue to look down into the earth, where there was ore to be found, whereas he wanted to look up, where guided waves could propagate.

In 1955 he left Canada once more, to become a scientist at the National Bureau of Standards (NBS) in Boulder, Colorado. The Boulder period from 1955 to 1980 was enormously productive for Jim as he continued to publish papers at an astonishing rate. In 1963 he became a Senior Research Fellow and Consultant to the Director of

the Institute for Telecommunications Sciences and Aeronomy and in 1967 he was appointed Senior Scientist in the Office of the Director of ESSA Research Laboratories. In 1980 he became Director of the Theoretical Studies Group of the National Oceanic and Atmospheric Administration (NOAA). Along the way he was also Adjoint Professor in the EE department of the University of Colorado and a Founding Member of the Cooperative Institute for Research in Environmental Sciences (CIRES). From 1974 through 1978 Jim was Secretary of the U.S. National Committee of the International Union of Radio Science (URSI). In 1959 he played a prominent role in creating the journal *Radio Science* which initially was section D of the NBS Journal of Research. He was its first editor and served three terms. Jim originated the idea of North American Radio Science meetings as a joint endeavor of U.S. and Canadian URSI, along with the IEEE Antennas and Propagation Society. The first of these was held in the city of Quebec in 1980 and has been followed by similar joint meetings in Vancouver (1985), London, Ontario (1991) and Montreal (1997).

Jim was kind enough to send me congratulatory notes on a few occasions regarding papers that I published and I have since learned that this was characteristic of Jim. He was kind, unassuming, utterly unselfish and always ready to go out of his way to encourage and help younger graduates and colleagues to further their careers. He paid me a personal compliment when, as chairman of the technical program committee for the 1975 USNC/URSI winter meeting in Boulder, he invited me to give a paper at the combined session, saying that he wanted to see greater interaction between URSI and people in industry. As a result I gave a talk with the title "A Review of Reflector Antenna Development". It was later published in *Radio Science* (Aug.-Sept 76) with the more accurate title "Some Highlights in Reflector Antenna Development." It was at this meeting that my wife and I saw Jim and his wife, Gertie, in person for the first time since they left Jerome 23 years earlier. Fortunately, I was to see him much more often in future years at the winter URSI meetings or at the IEEE Antennas and Propagation Society's annual symposia.

Jim entered academia in 1980 when he moved to Tucson to take a position at the University of Arizona as Professor of Electrical and Computer Engineering, along with a cross appointment to the Department of Geoscience. In 1988 he accepted the prestigious position of Regents' Professor and in 1989 he retired from the university and once more turned his gaze downward, into the earth itself, where ore was to be found. He became a private consultant, specializing in the use of electromagnetic techniques for subsurface geophysical exploration. In October of 1994 there was a meeting in Tucson of, I believe, the Society of Exploration Geophysics. Jim knew that members would be coming from all over the US and Canada, so he painstakingly got in touch with former colleagues who had been with Newmont Exploration in Jerome in the 1950 era and invited us to a reunion at his home in Tucson. It was a memorable occasion and my wife and I met twenty or more old friends, most of whom we had not seen in about 40 years. Among the guests was the venerable Dr. Arthur Brant, walking with a cane pending hip replacement surgery.

In addition to the activities already mentioned, Jim somehow found the time to take on a heavy load of editorial duties, among them three terms as Associate Editor of the *Journal of Geophysical Research* (1964-1969), U.S. Editor for the International Series of Monographs on Electromagnetic Waves published by Pergamon Press, Co-Editor of the Institution of Electrical Engineers (IEE) Electromagnetic Wave Series (London) and, finally, Member, Editorial Board of the journal *Pure and Applied Geophysics* (Zurich). In 1995 I had occasion to ask Jim for his comments on an article that I was reviewing. Graciously as ever, he replied almost at once with a postcard filled with tiny writing, some of which was written along the side margins. I've since discovered that this was one of his favorite predilections. He included a remark that I thought to be cogent and it possibly may be of interest to others. He wrote, "It's amazing, but many paradoxical contradictions can be resolved if  $ls + jewl$  is never allowed to vanish. All other limits can be done first, before letting  $s + jew$  become vanishingly small".

Many honors were accorded Jim during his career. The Hertz award is one of the IEEE's most prestigious. It carries a gold medal, a bronze replica, a certificate and a check for \$10,000. The citation for Jim's medal reads, "For fundamental contributions to electromagnetic theory, to the study of the propagation of Hertzian waves through the atmosphere, ionosphere and the earth, and to their applications in communications, navigation and geophysical exploration". It was formally presented, along with other awards and major medals, at the IEEE Honors Ceremonies in May of 1992 at the Sheraton Boston Hotel and Towers. Jim himself was not there to receive it! He disdained pomp and circumstance and was not at all pleased with the prospect of dressing in a tuxedo with black tie and wing-tipped collar. I cannot be sure that he deliberately arranged it but he did manage to schedule some lectures in England and he requested that the IEEE find a stand-in for him. I happened to be the chairman of the IEEE Hertz Medal Committee at the time, so I was elected to receive it on his behalf. It was an extremely impressive ceremony and I must say that the IEEE did (as is usual) a magnificent job on that occasion. Jim later became a member of the Hertz Medal committee and he always insisted on referring to it as the **P** medal, the bold Greek letter symbol for the Hertz vector.

When Jim died on October 1st, 1998, he left an immense legacy in the form of 8 books and more than 800 published papers. His contributions to the electromagnetic sciences were vast and in some cases pointed the way to new fields of research. Impressive as this is, it is not the full measure of the man. As great a scientist as he was, he remained kind, humane and, above all, a modest man.

Allan Love  
Corona del Mar, California

Although he was only 10 years older than me, Jim Wait was a somewhat legendary figure for me early in my career. He had been at the Radio Physics Laboratory of the Defence Research Telecommunications Establishment at Shirley Bay, Ottawa from 1952 to 1955 while I was a summer student at the Radio and Electrical Engineering Division of



the National Research Council (NRC) in 1955, a junior research officer 1956-57 and after my graduate studies an assistant research officer from 1961. Jim was well known personally in Ottawa and he had published many papers in the Canadian Journal of Physics (CJP), an NRC sponsored journal to which we then usually sent our papers, but I had never met him. One day I looked up from my desk to see the towering figure of D.W.R McKinley, the director of our division, with a handful of papers which Jim had submitted to CJP that he had been asked to review. McKinley's field was radar meteorology, he had published a book on it and Jim Wait, a non specialist in his area, had already published a highly cited paper on scattering from ionized cylinders directly applicable to it. My instructions from the director were to find all the errors I could in Wait's papers and report them to him and the editor. His parting advice was "Anyone who publishes so much as he, must make mistakes!". It was a command performance and I duly went over the papers in great detail, spending much time working through the equations, but all I could find were a few trivial typographical errors. Afterwards the editor of CJP sent me apparently all Jim Wait's papers that he received to review. For awhile it almost seemed Jim was producing them faster than I could review them. Once I found a paper which anticipated his but never a significant error. In this way I acquired a great admiration for the quality as well as the quantity of J. R. Wait's work and in addition a growing desire to know how he did it. After all this was an important matter for almost every young researcher.

A close friend and an excellent applied mathematician in 1965 had a related experience. This was in connection with a difficult land-sea propagation problem for which Jim Wait had published earlier a short approximate solution. Suspecting Wait's solution to be oversimplified and inaccurate, he managed with considerable effort and skill to extract some accurate numerical results from P.C. Clemmow's rigorous formulation in terms of unsolvable dual integral equations, only to discover results from Wait's simpler solution agreed with them. Wait's work is characterized by early recognition of the important physical parameters, accurate approximations and the simplest, most direct solution. Mathematics is used skilfully but never allowed to obscure the way to practical results. Consequently his work is usually of great value in scientific and engineering applications. Years later, after I had met Jim and his wife at a conference in 1983, I asked Gertrude privately how Jim managed to publish so much more than the rest of us. It seemed inappropriate somehow to ask Jim. She said simply that he worked a six day week. It was not a satisfactory explanation.

Later, after he retired from Boulder, I became aware that Gertrude's parents had retired to Vancouver and I tried unsuccessfully to lure Jim into being a candidate for department head here. It seemed to be the only way we could have him come to UBC. Quite sensibly he did not desire such positions but he did agree to a visit of a few interrupted weeks in 1987 while on sabbatical from the University of Arizona. I thought that at last I had an opportunity to find the answer to my question. Jim's expertise was interdisciplinary and here he was also able to collaborate and consult with colleagues in geophysics and

chemistry as well those in power line transients in electrical engineering. His also gave several seminars and lectures both here and downtown to geophysicists. He also went off jogging regularly each day. So he was often away from the office close to mine which I visited frequently in the hope of spotting him dashing off papers. At the end of his last short visit I asked him to provide the title to anything he might have written here to for my report to the granting agency which provided for his accomodation at UBC. As I had not observed him writing any papers, it was a surprise to receive a list of three which he had written. Even more surprising, a few months later I received a copy of a preface to his latest book which stated "most of the writing of this monograph was done while I was a visiting professor at the University of British Columbia" This was accompanied by note from Jim which claimed "I really did most of the writing in Vancouver with a bit in Alaska"!

Jim made another short visit in April 1991 and we managed to get in a day of skiing at Whistler. He was an expert skier from his time in Ottawa and Boulder and I was unable to keep up to him. This visit also passed without my further enlightenment as to how he published. Perhaps to deepen the mystery, to my knowledge he never personally used a computer, claiming, like Leo Felsen, his head was his computer. He was due to visit again in Oct 1998 when the arrangement was cancelled about two months before his death. The puzzle of how he was so incredibly productive remains unsolved for me. It is all the more remarkable because he was so extremely generous of his time and talents in helping colleagues and acting as a reviewer and editor of journals and books. He was especially generous in his praise of others, particularly of younger colleagues like me who will be grateful for the rest of their lives for his encouragement and his boost to their careers. We have lost not just a giant in our field, but also, and more significantly, we have lost a friend.

Ed Jull  
UBC, Vancouver, Canada

In June 1959, URSI Commission VI Symposium on Electromagnetic Theory was held in Toronto, Canada. Jim Wait was one of the key organizers, and he led discussions on various characteristics of "surface waves," an important topic at that time. I was just starting as an assistant professor at the University of Washington, and the Toronto symposium was one of my earliest experiences with URSI Commission VI (which later became Commission B) symposia. I was awed by these discussions presented by world experts such as Jim Wait. I listened to Jim, but did not talk with him then.

At that time, I had a master's student, Dobrott, who was working at BSRL (Boeing Scientific Research Lab). His thesis was on the East-West effects on VLF propagation between the earth and the ionosphere. BSRL was actively inviting world experts to give lectures. Bernard Friedman of the University of the California gave excellent lectures and helped us in our research. Jim Wait came in May 1960, and on May 24, Dobrott and I made an appointment to see Jim at the Olympic Hotel in downtown Seattle. Jim immediately suggested having a snack and beer at a nearby restaurant, and we explained our research to Jim. We were



a little nervous that this world expert might point out some flaws in our work. The East-West effects had already been studied by Wait and Crombie, and we are afraid that Jim might dismiss our work as a minor contribution. It turned out, however, that Jim was very kind and encouraging and made several suggestions to improve our work. He encouraged us to submit the paper to the Journal of Research of the National Bureau of Standards-D Radio Propagation. The Journal of Research, along with the IRE Transactions on Antennas and Propagation, was a premier publication in this field and was split into four sections in July 1959, and Jim was the first Editor. We were overjoyed by Jim's encouragement, and our paper was published in January 1961.

The journal became "Radio Science", and Jim served as Editor many times. When Tom Senior became Editor in 1972, I started serving as an Associate Editor for Commission VI, and in 1979, I was appointed Editor of Radio Science. The Editor Search Committee consisted of Jim Wait, Sid Bowhill, and Tom Senior, all world renowned experts, and I felt very fortunate for being chosen. Immediately after I became Editor, I consulted Jim for advice, and Jim immediately offered to become an Associate Editor to help me out. I relied heavily on Jim's advice and help throughout my term as Editor. After he moved to the University of Arizona, whenever he corresponded with me, he changed the logo (A) of the University to  $\nabla \bullet \mathbf{A} = \psi$  as he must have done to all of us. He was a true scholar and gentleman. He gave immeasurable help and encouragement freely. We will miss this giant.

Akira Ishimaru  
University of Washington, Seattle, WA

First, I would very much like to thank Dick Dowden for suggesting I write a few words about Jim Wait. Like many of you who may read this, I started out in the mid 1960s being totally in awe of Jim for his many diverse and truly fundamental contributions to the understanding of radio wave propagation and scattering. I well remember as a graduate student, staying up all hours of the night reading papers in which he was able to understand many complex and detailed wave-medium interaction processes through the simple use of a surface impedance boundary condition. He had the unique ability, that many of us seek, to know when to attack a fields problem with exact methods and when to back off and use approximate techniques. To place things in perspective, it should be remembered that many of his fundamental results were obtained back when fast computers did not exist and understanding and approximate descriptions were the cornerstone of electromagnetic engineering. As time progressed, his technical accomplishments never really diminished as his contributions to radio science continued even to just shortly before his death as evidenced by a paper he wrote that was just published in the October 1998 issue of the *IEEE Antennas & Propagation Magazine*.

Many things have been said and written about Jim's innumerable *contributions* and his *character*. I would like to add one more "c" to this list and it is his *compassion* for his profession. Of all the contributions he has made to radio science this is the one that is probably the least well known;

the reason for this is that it was not something that Jim sought glory or publicity for. He felt very deeply about all aspects of his profession and he did many things to enhance the stature and well being of it. He did not hold office in any of the major organizations such as URSI, USNC-URSI, AGU, or any of the various IEEE Societies he participated in. I often wondered why this was the case and while I never asked Jim the reason, I rather suspect that it was because he felt he could do more outside the leadership structure as a *friendly advisor* than being directly in it! I assume this based upon my interactions with Jim during my tenure as an officer of IEEE AP-S and USNC-URSI. I remember well the times when I was feeling pretty good about the way an organization was running or the directions it was heading and then I would get a phone call from Jim alerting me to a potential problem. Usually the problem was what I would classify as rather long range, e.g., it didn't require my attention in the next week, so when his calls first started they were put on my "back burner". However, when reviewing my notes prior to meetings or decision points, I would recall my conversations with Jim and realize that he had identified the problem well in advance of its elevation to the status of "a real problem"! I should say that these calls were neither frequent nor were they long or time consuming. They were simply Jim's way of saying "Here's something that I've come across and I think you may want to keep an eye on it or discuss it at the next meeting."

In fact, it was such a call in late August that was the occasion of my last conversation with Jim. He had been to a meeting dealing with the problems of one our major technical journals and he did not agree with some of the reasons suggested by other attendees for the source of the problems. His stated purpose for calling me was to "get my feelings on the situation". I, never being shy about expressing such feelings, was most happy to share them with Jim. However, after completing our call I could not escape the feeling that Jim was really trying to accomplish something else. I think he was trying to plant the seed of concern in *my mind* in the hope that it would grow into a full-blown effort to not let this major journal diminish in stature or quality. In fact, I am convinced that this was the real purpose of his call because this is the way Jim felt about his profession and all things connected with it! Jim was very compassionate about his profession and while he was not a shouter and a screamer about such matters, he knew *exactly* who to talk with and what to do to get problems corrected. While Jim did not occupy many leadership positions in professional organizations, he was certainly most instrumental in *steering* the direction of our profession and professional organizations to the "high ground" through quiet diplomacy and true dedication.

His dedication, wisdom, and counsel will be greatly missed either directly or indirectly by every member of the radio science community. Finally, I should add one note that is so typical of Jim's character. When I last spoke with Jim on the phone in late August last year [1998], there was not one word or hint from him that he was suffering from a terminal illness.

Gary Brown  
Virginia Tech, Blacksburg, USA

I first became aware of Jim Wait's outstanding work in electromagnetics (EM) when I was a graduate student at Ohio State in the late 1960s. My PhD thesis involved sources and scatterers located near interfaces, and a literature search quickly revealed that Jim had already published most of the necessary solutions for various dipole types (horizontal and vertical, electric and magnetic) in journal articles or in his classic book, *Electromagnetic Waves in Stratified Media*. After making full use of this work in completing my thesis, I applied for and was awarded a postdoc position under Jim in 1970 at the Cooperative Institute for Research in Environmental Sciences (CIRES) in Boulder.

Jim was a founding member and Permanent Fellow of CIRES, and he was one of the main forces in making this small organization such a stimulating, productive place to work. He liked having both young and well established researchers (Dick Dowden was a Visiting Fellow the same year that I was there) in CIRES and worked well with both. Initially I was nervous about working with a world-famous scientist who was so well known for his speed in solving problems and writing papers, but Jim quickly put me at ease with his friendly, relaxed style. He was not only a good mentor in EM, but he was also an outstanding skier who was glad to pass on a few tips to a novice like me.

Jim generated a continuous stream of hand-written mathematical derivations in a wide variety of electromagnetic problems, and he liked to see what others could add in the way of extensions, applications, or numerical results. This style was the most unselfish I have ever encountered, and he never worried about whose name was first on the resulting paper. (But he did require that the paper be all meat and no fat.) I chose to follow up some of Jim's interesting results on pulse propagation in ionized media even though I had no background in the area. It was always comforting to know that Jim had researched the area thoroughly and knew which problems were unsolved and important. To this day I have never known anyone else who knew the EM literature in such detail and over such a broad range.

In 1971 when I finished my visiting year, positions in the Boulder Laboratories were hard to come by. Even so, Jim used his significant influence to help me obtain a permanent position in Boulder, and I have been grateful ever since. Although we were in different Boulder organizations in the remainder of the 1970s, Jim and I continued to work together in several areas (subsurface EM, ground-wave propagation, scattering by wire mesh structures, and leaky cable communications). He always felt that organizational boundaries and missions (such as remote sensing, telecommunications, or electromagnetic standards) should not get in the way of solving electromagnetic problems that are fundamental to all EM laboratories. So Jim kept close connections with all the Boulder Laboratories and the University of Colorado EM Group and stimulated EM research throughout Boulder.

When Jim moved to the University of Arizona in 1980, it was Boulder's loss and Tucson's gain. Even so, Jim continued to return to Boulder, and I had the opportunity to lecture in one of his short courses on Geophysical Electromagnetics (probably his first love in EM). I also enjoyed seeing Jim at the January Boulder URSI Meetings,

and we even got in a couple ski days. Most of all, I appreciated the fact that he continued to send his classic hand-written mathematical derivations on new EM problems to see if I wanted to collaborate. Sometimes I did, and it was always fun to try to produce papers up to his usual high standards. I guess I thought that Jim's hand-written letters full of mathematics would continue arriving forever, and now I regret the cases where I did not respond.

I last saw Jim at the Denver EMC Symposium in August 1998, and our conversations ranged from EM to mountaineering. So it was a shock when I learned of his rapidly progressing cancer. Jim's enthusiasm for EM continued even during his illness, and he sent me one last set of mathematical notes on ground-wave excitation by an idealized lightning return stroke. I am still working on the problem, and I hope to publish it as partial thanks for all that Jim has done for me and has meant to me.

Dave Hill  
NIST, Boulder, CO, USA

I first came in contact with Jim Wait through my supervisor and friend Professor Richard ("Dick") Dowden. Dick had recently discovered evidence that Red Sprites had a complex electrical structure, and in December 1995 he visited Jim in Tucson, Arizona. Driving back from a Wait family Christmas celebration they discussed the problem of VLF scattering from closely spaced ionised columns. The next day, Jim bicycled round to Dick's motel room with 4 postcard sized pieces of paper, covered with closely spaced writing. It ended "Dick, this is a good start, do you have a PhD student to work on this?" It wasn't a good start, it was a complete solution, and it turned out to be the main basis of my PhD thesis, even though it was delivered to me about 60% of the way through my time. From these 4 wee slips of paper Jim and I started exchanging letters — for Jim never used email. A letter from Jim Wait was an icon in itself, often only postcard sized and covered in writing and equations. Having written down the page Jim would write in the corners and down the sides, adding little notes and asides, all of which required careful translation and consideration. The Signal/Noise ratio of anything from Jim was very high!

The communication between Jim Wait and myself was very successful. These 4 wee slips of paper and the subsequent communications didn't just form the basis of my PhD thesis. The ideas presented on them produced 4 papers in AGU journals (plus one correction — my fault), and are important parts of at least another 3 (Jim and I are also joint authors on another paper, plus one which is currently in the works). I presented elements of this theory in the AGU WPGM Brisbane, PIERS97 Hong Kong (where I was Jim Wait's representative, due to ill-health), local meetings in Dunedin, New Zealand, and MMET98 Kharkov. In all these cases Jim was my co-author, but more than that, he was the reason I could go to these international meetings and present. Jim was amongst the most generous scientists I know — he sent me material which were almost fully formed papers, ready to go, and after I went to Hong Kong I knew I wasn't the only one. I was told that Jim was happiest when he was talking to the students in the poster sessions at conferences, helping them along. In practise Jim Wait was my third PhD supervisor, alas only connected to

the final celebrations by the photographs I sent him. After I finished my PhD he helped me again, writing one of the supporting letters which won me a Post-Doc at the British Antarctic Survey in Cambridge. And our scientific correspondence ebbed and flowed but did not stop.

The influence that Jim had on my career was huge, and I know am not alone in this. The community, and I, have lost a fine scientist and a great man. Perhaps because Jim and I wrote letters rather than email, or maybe because of our complementary "writing styles", we discussed much more than Science. Jim was a Canadian who left his country after graduating from the University of Toronto. He told me that when he finished his PhD they only hired Oxbridge graduates, and so he ended up heading for the USA (this is how the Empire lost the best and brightest!). He watched the UK Prime Ministers Question time every week on CNN, and considered himself to sit in the middle ground. He had 3 degrees from Toronto, and a "T" in skiing. He was planning on attending the URSI General Assembly to be held in Toronto in August 1999. I spoke to Jim twice on the telephone, but never met him in person. I had hoped to meet him for the first time at the General Assembly, to try to properly thank him for all his generosity towards me.

Craig J. Rodger  
British Antarctic Survey, Cambridge, UK

I can tell Jim Wait stories by the hour. It is difficult for me to select one from a veritable barrage of ammunition. However, I have chosen to relate one of the most endearing, though sometimes frustrating, parts of his many-faceted and complex personality.

Jim was always leaving. Even when arriving, he was in the process of leaving. It did not matter what the venue was; social, business, meetings, sports; he was inevitably, constantly, and invariably... leaving.

If we were walking together across campus, I soon found him ten steps ahead and the distance between us rapidly diverging. While teaching class and writing on the blackboard, he was forever leaving one equation and embarking on another, usually without finishing the first, because it was so obvious (to him) how the first equation ended. Skiing with him was an exercise in watching him disappear. I never, ever, reached the bottom of the mountain before him, or even with him. I almost expected him to leap out of the chairlift on the way UP the mountain.

Jim and I lived near each other, about a mile from the University. We biked to school, often together, if you use "together" in a very loose sense. Biking with him was hilarious. We would begin by talking about science or department politics or students; but in mid-sentence, I would discover that he had left me behind, talking to myself.

And now, Jim has left again. This time it seems more permanent; but, I wonder. I just recently have begun to understand that Jim is still with me in a very important way. Indeed, I now realize that Jim has not left; for me, he is still leaving.

Don Dudley  
University of Arizona

Much of what I might have said about Jim has been said above, but a couple of personal experiences might throw some light on the great mystery — how did Jim produce so much when his colleagues at the time didn't see the expected activity? In 1956 on Macquarie Island I discovered that apparently very low altitude "C-layer" echoes on my ionosonde were really sea echoes. Jim read my published paper (my first) and began correspondence. Some ten years later Jim suggested I apply for a CIRES Fellowship which I got and took up just before Christmas 1969 for 12 months (the same year as Dave Hill). That was my first actual meeting of Jim. Over the previous decade my mental picture of Jim was a sort of boffin. Surely, to produce so many papers and books, he must dictate to several typists simultaneously and do nothing else! To my great surprise, he seemed quite the reverse. He was an extraordinarily generous host — he invited all eight of us (me, my wife and six young children under 10) to his house for Christmas. There were presents on the tree for all of us by name, each one just right for the intended child. Next I found that he skied nightly after work.

About 20 years later I discovered his secret, the puzzle which eluded Ed Jull and others, when he came to my university (Otago) on a six-week sabbatical. Which was? He could do things in about a tenth of the time as the rest of us do. I saw him write a paper by hand as if it were being dictated to him: title, author, abstract, etc, all in order. He must have had it all in his mind before he started to write. He knew the literature so well he remembered the references, even the volume and page numbers. He didn't need any feverish activity to do this; just extraordinary efficiency. He didn't mind being interrupted (he was never "busy"). He had time for everyone; to him no one was inconsequential.

On another occasion during this period he noticed a copy of my PhD student's thesis which had been submitted long before Jim arrived and had already been in the hands of the external examiners for several weeks. With my willing agreement he took it home to his hostel for the evening. Next morning he returned the copy with "a few notes" — 3 sheets of gentle critique in his inimitable hand writing which was far deeper than either official examiner managed in a couple of months.

The last time I saw Jim was when I visited him in Tucson in December, 1996. This began with a tour of Tucson by bicycle (his and one he lent me). I couldn't keep up, being exhausted and saddle sore, and begged an earlier return. Only a few days later it was Christmas and he invited me to Christmas dinner again exactly 27 years after the one in Boulder. It was during the long drive back from Christmas dinner at his relative's place that I put the problem to him that Craig Rodger related above and which Jim had solved by the next morning (Boxing Day).

I think many of us will agree with Don Dudley that Jim is still with us and having a great influence on us, even on those like Craig whom he never met.

Dick Dowden  
Dunedin, NZ



It is really a pleasure and at the same time a hard task to express a Young Scientist's view on a General Assembly of the URSI in a few words. For me the experience is restricted to that in the last General Assembly held in Lille, France. In a simple way, the assembly as a whole had a serious impact on the academic motivation of all the individual young researchers. The outcome can only be effectively felt within a few years to come and thus now I feel an urge to express my views as a URSI Young Scientist within my limitations.

The first overwhelming experience of that event in Lille, France was to meet a galaxy of radio scientists and engineers in the "Grand Palais", the conference venue of that year, which added an extra flavour to the August assembly. The seven day long meeting offered a grand scope of interactions with a vast number of researchers dealing with similar or allied problems. And more important was the scope of being introduced with the newly growing fields of research along with the leading scientists involved. This latter one especially urged me to innovate new and more fascinating avenues of research of today.

The assembly of a large number of young scientists also played an important role to the awardees in another form. The young researchers from every part of the world, due to their age alike and like fields of activities were found to utilise that opportunity to exchange their ideas, to collect information of academic interests and in general, to make a good friendship among themselves. The welcome party for the Young Scientists actually initiated that scope of close interactions. That event on a rainy evening will remain evergreen in my reminiscence. I personally experience its direct effect in maintaining academic exchanges and relations with different Universities and Laboratories of different countries in the world.

Apart from the parallel scientific sessions, the poster session itself was worth mentioning. The well arranged lobby of the "Grand Palais" (name of the convention centre) accommodating more than five hundred posters cherished the flavour of an academic fair. Very close and direct interactions were there. One such interesting as well as serious interaction was experienced by me. A paper of mine

was also in that session and a photograph of a new device was displayed. I was standing in front of my own. A young person came, read, showed his curiosity and asked me the price of the device as he wanted to purchase that for one

immediate application. Such a serious and instantaneous thinking about the application of the newly proposed device which was not in my mind at all, inspired and sparked me a lot. Another informative thing, at least to the younger ones was the Industrial Exhibition, but they missed a workshop that time. However, the guest Lecture by Professor Joseph

H. Taylor, a Noble Laureate, the general lectures and the tutorials were highly illuminating and enjoyable too.

The registration kit included free copies of two books published by URSI along with the 'heavy' book of abstracts of the conference. We had enjoyed those articles in two ways, once during carrying in course of the return journey and later, really on the desk as a guide to the state-of-the-art technologies in radio science. The young worker like me was thus benefited in different ways. The Radio Science Bulletin, an URSI periodical, which I have been receiving as a URSI Correspondent for this triennium is very much interesting and attractive to me. I personally enjoy this as a real bulletin on the current ongoing activities throughout the world and in that way it helped me in participating in some activities of our region.

The young scientist's view would remain incomplete if it didn't mention the pleasure to get recognition from a prestigious scientific organisation like URSI. The award in

its form of providing the huge financial support is really appreciable to all, particularly to those working at the remote parts of the world. Otherwise a young researcher like me from an Indian University

could not find this opportunity to note his satisfaction this way. The untold fact that still remains behind is the ungrudging co-operation and help of the URSI secretariat in guiding all the way without which our participation would not be so easy and smooth in all respects.

Debatosh Guha

Institute of Radio Physics and Electronics  
University of Calcutta, Calcutta, India

fax +91 33-351 5828, E-mail dguha@cucc.ernet.in

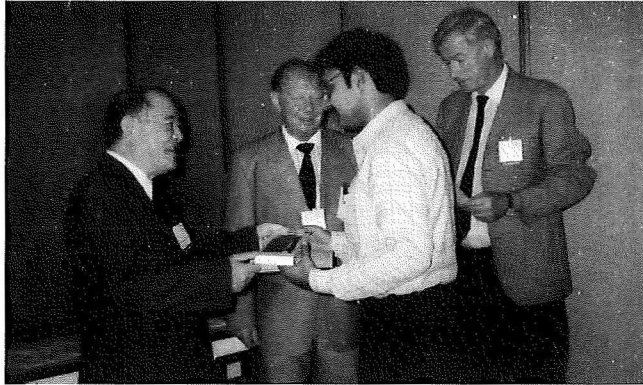

*from left to right: Prof. Shizhang Feng, Dr. Pierre Bauer, Dr. Debatosh Guha, Prof. Edward V. Jull*



*The author (third from the left) at the Young Scientist Party, URSI General Assembly, Lille, France, August 1996*



## GERMANY

### Kleinheubacher Tagung, 27 September - 1 October 1999

Vom 27. September bis 01. Oktober 1999 veranstaltet der URSI-Landesausschuß in der Bundesrepublik Deutschland in Zusammenarbeit mit den ITG-Fachausschüssen 5.1 (Informations- und Systemtheorie), 7.5 (Wellenausbreitung) und 8.4 (Integrierte Systeme) seine Jahrestagung im Schloß Kleinheubach (Main).

Wissenschaftlicher Tagungsleiter ist: Dr. Ulrich Stumper, Laboratorium für Hochfrequenzmeßtechnik, Physikalisch-Technische Bundesanstalt, Bundesallee 100, Postfach 3345, 38023 Braunschweig, Tel: 0531-592-2220, Fax: 0531-592-2228, E-mail: ulrich.stumper@ptb.de

Es werden Anmeldungen zu Vorträgen und Postern erbeten zu folgenden Schwerpunktsthemen und Arbeitsgebieten der URSI Kommissionen:

#### Schwerpunktthemen

- ST1 Satellitennutzung für Zeitübertragung, Navigation, Geodäsie und Ionosphärenforschung
- ST2 Interaktionen elektromagnetischer Felder mit biologischen Systemen
- ST3 Realisierungsaspekte kostengünstiger Implementierung für Mobilfunkgeräte der dritten Generation
- ST4 Verlustarme Schaltungstechnik für die Informationsverarbeitung

#### Arbeitsgebiete der URSI Kommissionen

- A. Electromagnetic Metrology - Zeit und Frequenz, Metrologie im Hochfrequenzbereich
- B. Fields and Waves - Berechnung elektromagnetischer Felder, Antennen
- C. Signals and Systems - Theorie, Anwendungen
- D. Electronics and Photonics - Integrierte Optik, Optische Nachrichtenübertragung

- E. Electromagnetic Noise and Interference - EMV-Analyse, EMV-Messungen
- F. Wave Propagation and Remote Sensing - Direktes und synthetisches Apertur-Radar, Wellenausbreitung
- G. Ionospheric Radio and Propagation - Polare Sommermesosphäre, Weltraumwetter
- H. Waves in Plasmas - Nichtlineare Wellenausbreitung, Turbulenzen und Chaos
- J. Radio Astronomy - Instrumentierung
- K. Electromagnetics in Biology and Medicine - Effekte schwacher Felder, Wirkungsmechanismen

Für eingeladene Übersichtsvorträge stehen i.a. 30 Minuten und für Einzelreferate 15 Minuten Sprechzeit zur Verfügung. Für Poster ist eine mündliche Kurzpräsentation sowie ein Aushang mit Diskussion zu einer festgelegten Zeit vorgesehen.

Um das Tagungsprogramm mit den Kurzfassungen der Vortragsanmeldungen ein wenig kompakter und attraktiver zu gestalten, bitten wir, die Kurzfassungen der Vortragsanmeldungen der Anleitung entsprechend abzufassen und bis spätestens 15. Mai 1999 zu richten an: Copernicus Gesellschaft, Kleinheubacher Tagung 1999, Max-Planck-Str. 13, D-37191 Katlenburg-Lindau, URSI@COPERNICUS.ORG.

Die Benachrichtigung über die Annahme der Vorträge erfolgt Ende Juni 1999.

Vortragende, die ihren Beitrag in den Kleinheubacher Berichten veröffentlichen möchten, werden gebeten, die Richtlinien für die reproduktionsreife Manuskriptvorlage zu berücksichtigen und ihr Manuskript entweder im Tagungsbüro abzugeben oder bis spätestens 31. Oktober 1999 an die Copernicus Gesellschaft zu schicken. Der Bericht sollte vollständig aber kurz sein und sich auf die wesentlichen Ergebnisse beschränken.

## ISRAEL

### Annual Meeting

The annual meeting of the Israel Committee was held on the campus of The Technion I.I.T., Department of Electrical Engineering, on December 21, 1998 and organized by Dr. Jacob Halevy-Politch.

The general morning session had four lectures:

1. Professor Dag T. Gjessing, "Characterization of ocean phenomena by the use of EM waves".
2. Dr. Naftali Chayat, "Conceptual introduction to Turbo Codes".

3. Professor Willem Baan, "The next generation radio telescope - The square kilometre array: Technical challenges and scientific prospects".
4. Professor M. Tur and A. Zadok, "Optical code division multiple access (CDMA) networks".

In the afternoon there six parallel sessions were held:

1. Commission A: "Electromagnetic metrology", chaired by Professor Ben-Zion Kaplan (5 lectures).

2. Commission C: "Signals and Systems", chaired by Professor I. Bar-David (5 lectures).
3. Commissions D & K: "Electronics and Photonics", chaired by Professor Y. Namirowsky (6 lectures).
4. Commission E: "Noise and Electromagnetic Interference", chaired by Mr. O. Hartal (5 lectures).
5. Commissions H & F: "Waves and Plasmas and Remote Sensing", chaired by Professor Mond (4 lectures).
6. Commission J: "Radio Astronomy", chaired by Dr. N. Brosh (7 lectures).

Requests for information can be directed to:

Dr. Jacob Halevy-Politch  
 Head, Commission A, URSI - Israel  
 16th. O. Box 7205  
 Haifa 31071, Israel  
 Tel./Fax (H): (972)4.8243276  
 Tel.(W): (972)4.8794862  
 Fax(W): (972)4.8794875  
 E-mail: aeryapo@tx.technion.ac.il  
 Jacob Halevy-Politch

## KOREA

### Fourth CDMA International Conference and Exhibition

CIC'99, the 4th CDMA International Conference and Exhibition, will be held in Seoul, Korea from 8 to 11 September 1999. It is hosted by the Ministry of Information and Communication. The International Advisory Committee Chair is Seon Jong Chung (ETRI), the Organisation Committee Chair is Hyuckjae Lee (ETRI) and the Technical Program Committee Chair is Byeong Gi Lee (Seoul National University).

In the spirit of the commemoration of the successful CDMA cellular and PCS system deployments in Korea, CIC has been organised and successfully demonstrated its potentiality to the academia by providing a forum for exchanging the leading edge technology in mobile communications. The 4th CIC will be furnished by two days of invited speakers from manufacturers and service providers and one and half days of paper presentations including tutorials by distinguished lecturers for various technical perspectives of CDMA, specifically focused on IMT-2000 and future technologies beyond the 3rd generation mobile communications. Especially technical exhibition is also scheduled in the same area. Technical papers are welcomed in all areas of CDMA systems and technologies.

Areas of interest include, but are not limited to : Cellular Mobile Communications, Narrow Band CDMA/ Wide Band CDMA, CDMA Mobile Phone Technology,

Spread Spectrum Technology, Algorithm for Channel Assignment, Acquisition & Tracking, Wireless Multimedia Services, Wireless LAN/Wireless Data, Multiple Access Technology, Interference Rejection Technology, Power Control, Smart Antenna, Antenna and Propagation, Wireless ATM, Modulation & Coding, Satellite Communication, IMT-2000, Personal Communications, Resource Management, Call Admission Control, Mobility Management, Handoff Algorithms, ITS, Wireless Local Loop(WLL), Diversity Technique, Teletraffic Modeling, Security in Mobile Network, VLSI Implementation, MMIC Implementation, RF Technology.

#### *Deadlines*

Full Paper Submission : May 15, 1999  
 Notification of Acceptance : June 30, 1999  
 Camera-Ready Paper due : August 15, 1999

#### *Contact*

Dr. Kisuk Yoo  
 Electronics and Telecommunications Research Institute  
 161 Kajong-Dong, Yusong, Taejon, 305-350 Korea  
 +82 42 860 6458(Tel) +82 42 860 5199(Fax)  
 E-mail: [ksyoo@etri.re.kr](mailto:ksyoo@etri.re.kr)  
<http://satmain.etri.re.kr/cic/index.html>

**INTELLECTUAL AND CULTURAL DISTINCTION  
HONORIS CAUSA**

On 17 November 1998, Professor Michael J. Rycroft, of the International Space University, Strasbourg, France, was one of five honorands - honorary graduates - at a graduation ceremony of De Montfort University, Leicester, UK. He was awarded a Doctor of Science (Honoris Causa) degree for "his high intellectual and cultural distinction", as evidenced by his career in space and atmospheric science and by his responsibilities in both national and international organisations.

Michael J. Rycroft was born in Rickmansworth, England in July 1938. He graduated from Imperial College London in Physics and went on to Cambridge to take a PhD in Meteorological Physics. After postdoctoral positions at the NASA Ames Research Center in California and at Imperial College, he became a Lecturer in the Physics Department at Southampton University,



and then Head of the Atmospheric Sciences Division of the British Antarctic Survey, Cambridge, where pioneering work on the ozone hole was carried out.

In 1990, he was appointed Professor of Aerospace and Head of the College of Aeronautics at Cranfield University. At the start of 1995 he took a new position as Head of the School of Sciences and Applications at the International Space University whose headquarters are in Strasbourg, France.

He has published more than 140 papers and edited 30 volumes, including the Cambridge Encyclopedia of Space. He is Editor-in-Chief of the Journal of Atmospheric and Solar-Terrestrial Physics, a member of four Editorial Boards, and a member of the

International Academy of Astronautics. Since 1988, he has been a Member of the Council of the Institute of Mathematics and its Applications.

**UTC Time Step**



On n'introduira pas de seconde intercalaire à la fin de juin 1999. La différence entre UTC et le Temps Atomique International TAI est:

de 1999 janvier 1, 0h UTC, jusqu'à nouvel avis : UTC-TAI = -32 s

Des secondes intercalaires peuvent être introduites à la fin des mois de décembre ou de juin, selon l'évolution de UT1-TAI. Le Bulletin C est diffusé deux fois par an, soit pour annoncer un saut de seconde, soit pour confirmer qu'il n'y aura pas de saut de seconde à la prochaine date possible.

Daniel GAMBIS  
Directeur, Bureau Central de l'IERS  
Service International de la Rotation Terrestre

No positive leap second will be introduced at the end of June 1999. The difference between UTC and the International Atomic Time TAI is:

from 1999 January 1, 0h UTC, until further notice : UTC-TAI = -32 s

Leap seconds can be introduced in UTC at the end of the months of December or June, depending on the evolution of UT1-TAI. Bulletin C is mailed every six months, either to announce a time step in UTC or to confirm that there will be no time step at the next possible date.

Daniel GAMBIS  
Director, Central Bureau of IERS  
International Earth Rotation Service  
Observatoire de Paris, 61, Av. de l'Observatoire  
F-75014 Paris (France)  
tel +33 1-40 51 22 26, fax +33 1-40 51 22 91  
Internet : services@obsrpm.fr

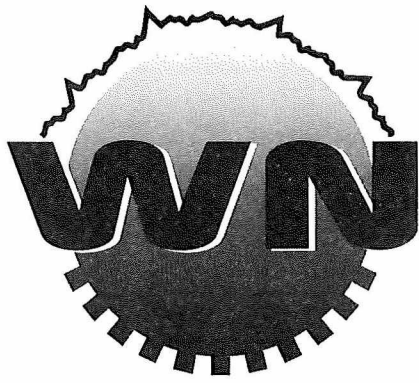

# Wireless Networks

The journal of mobile communication, computation and information

Editor-in-Chief:

**Professor Imrich Chlamtac**

Department of Electrical Engineering  
The University of Texas at Dallas, P.O. Box 830688  
MS EC33 Richardson, TX 75083-0688, USA  
E-mail: Chlamtac@utdallas.edu



Aims & Scope:

The wireless communication revolution is bringing fundamental changes to data networking and telecommunications and is making integrated networks a reality. By freeing the user from the cord, personal communication networks, wireless LAN's, mobile radio networks and cellular systems harbor the promise of fully distributed mobile computing and communications, any time, anywhere. Numerous wireless services are also maturing and are poised to change the way and scope of communication. **Wireless Networks** focuses on the networking and user aspects of this field. It provides a single common and global forum for archival value contributions documenting these fast growing areas of interest. The journal publishes refereed articles dealing with research, experience and management issues of wireless networks. Its aim is to allow the reader to benefit from experience, problems and solutions described.

Subscription:

**Wireless Networks** ISSN 1022-0038 Bimonthly  
URSI Correspondents Sfr.95.- / US\$ 65.- (including mailing and handling)  
Contact: Mrs Inge Heleu, Fax: +32 9 264 42 88, E-mail: heleu@intec.rug.ac.be  
Non members / Institutions: contact Baltzer Science Publishers (see below)

For the full tables of contents and information about electronic availability,  
please consult our homepage:

**BALTZER SCIENCE PUBLISHERS**

**<http://www.baltzer.nl/winet>**

Also for subscription information, order forms, author instructions and a catalogue  
of all journals published by Baltzer Science Publishers



Wireless Networks is published by  
Baltzer Science Publishers in cooperation with the ACM.  
Officially sponsored by URSI



P.O. Box 37208, 1030 AE Amsterdam, The Netherlands  
Tel: +31 20 6370061, Fax: +31 20 6323651,  
E-mail: [publish@baltzer.nl](mailto:publish@baltzer.nl)



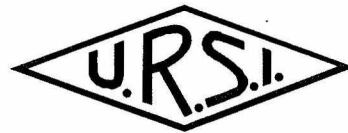

## Proceedings of the "Space and Radio Science Symposium"

Editors: Peter Van Daele and Paul Delogne  
ISBN 90-9008628-5

Union Radio Scientifique  
Internationale



International Union of  
Radio Science

Space and Radio Science Symposium

26-27 April 1995

26-27 April 1995



1995-1997

This "Space and Radio Science Symposium" was held on 26-27 April 1995, at the occasion of the 75th Anniversary of our Union.

Copies of these Proceedings are available at the URSI Secretariat for 12.39 Euro per copy (for countries outside Europe we charge an extra 3.47 Euro for mailing costs).

### Table of Contents :

- \* Prof. P. Delogne, President of the Technical Programme Committee  
"About the Programme"
- \* Prof. J. Van Bladel, President of the Koninklijke Academie  
"The birth of URSI"
- \* Dr. P. Bauer, President of URSI  
"The activities of URSI since its first General Assembly in 1922"
- \* Dr. J. Ponsonby (Nuffield Radio Astronomy Labs, UK)  
"Global Satellite Navigation Systems: Uses of Space-Time Fixe from Geodesy to Sailing"

- \* Prof. Y. Rahmat-Samii (University of California, Los Angeles, USA)  
"Antennas in Space : Modern Developments and Future Challenges"
- \* Dr. L. Chiariglione (CSELT, Italy)  
"The future of Digital TV and HDTV by Satellite"
- \* Dr. S. Kato (NTT Radio Communication, Japan)  
"Personal Communication Systems and Low Earth Orbit Satellites"
- \* Prof. M.A. Stuchly (University of Victoria, Canada)  
"Mobile Communication Systems and Biological Effects on Their Users"
- \* Prof. A. Kalmykov (IRE, Kharkov, Ukraine)  
"Real-Aperture Radar (RAR) Imaging from Space"
- \* Prof. W. Alpers (University of Hamburg, Germany)  
"Measurements of Mesoscale Oceanic and Atmospheric Phenomena by ERS-1 SAR"
- \* Dr. D. Massonet (CNES, Toulouse, France)  
"SAR Interferometry and the Monitoring of the Earth Surface at Centimeter Level"
- \* Prof. R.T. Schilizzi (Joint Institute for VLBI in Europe)  
"Future Developments in VLBI Astronomy on the Ground and in Space"
- \* Prof. C. Salomon (Ecole Normale Supérieure, Paris, France)  
"Cold Atoms and Microgravity Clocks"
- \* Dr. D.B. Snyder (NASA, USA)  
"Dynamic Interactions Between Ionospheric Plasma and Spacecrafts"
- \* Prof. D. Gurnett (University of Iowa, USA)  
"Solar System Plasma Waves"
- \* Prof. H. Matsumoto (Kyoto University, Japan)  
"Microwave Power Transmission from Space and Related Nonlinear Plasma Effects"

## Modern Radio Science 1996

Editor: Joël Hamelin  
ISBN 0-19-856530-5  
Price : £ 35

For further information, please contact :

CWO Department  
Oxford University Press  
Saxon Way West, Corby  
NORTHANTS NN18 9ES  
UNITED KINGDOM  
tel. +44 1-536-746-337  
fax +44 1-536-744-964

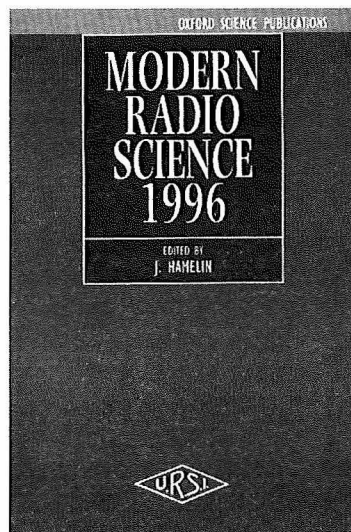

## Review of Radio Science 1993-1996

Editor: W. Ross Stone  
ISBN 0-19-856532-1  
Price : £ 95

For further information, please contact :

CWO Department  
Oxford University Press  
Saxon Way West, Corby  
NORTHANTS NN18 9ES  
UNITED KINGDOM  
tel. +44 1-536-746-337  
fax +44 1-536-744-964

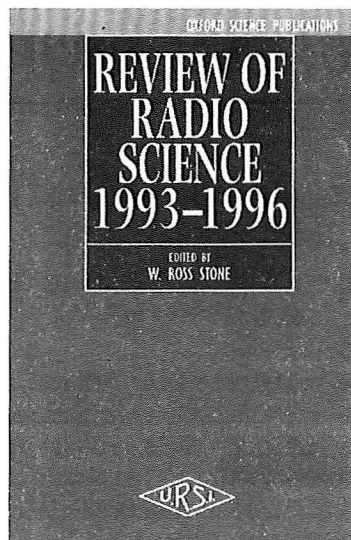

## Handbook on Radiopropagation Related to Satellite Communications in Tropical and Subtropical Countries

Editor: G.O. Ajayi  
with the collaboration of :  
S. Feng  
S.M. Radicella  
B.M. Reddy

Table of Contents :

- \* Chapter 1 : Attenuation by Rain and Clouds and Rain Rate Statistics
- \* Chapter 2 : Absorption by Atmospheric Gases including Prediction Models
- \* Chapter 3 : Ionospheric Effects on Space Communications Systems
- \* Chapter 4 : Attenuation Prediction Models for Design of Satellite Systems
- \* Chapter 5 : System Design for Point-to-Point Satellite Services
- \* Chapter 6 : System Design for Broadcasting Satellite Services

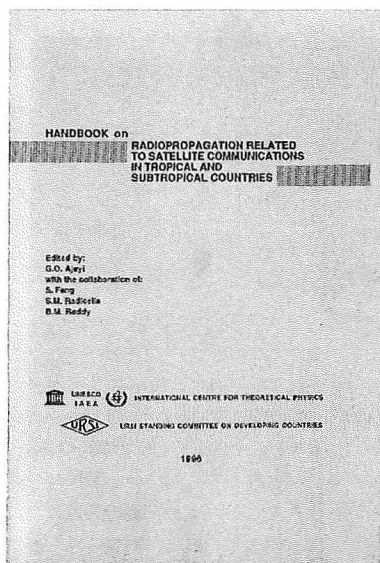

For further information, please contact :

The URSI Secretariat  
c/o University of Gent (INTEC)  
Sint-Pietersnieuwstraat 41  
B-9000 GENT, BELGIUM  
tel. +32 9-264-33-20  
fax +32 9-264-42-88  
e-mail : heleu@intec.rug.ac.be

# Radio Science

*Bimonthly!*

**Radio Science** contains original articles on all aspects of electromagnetic phenomena related to physical problems. Covers the propagation through and interaction of electromagnetic waves with geophysical media, biological media, plasmas, and man-made structures. Also included, but not limited to, are papers on the application of electromagnetic techniques to remote sensing of the Earth and its environment, telecommunications, signals and systems, the ionosphere, and radio astronomy. All frequencies, including optical, are of interest.

See a recent Table of Contents on the AGU Web Site: <http://www.agu.org>

Volume 34, ISSN 0048-6604. Print or microfiche.

## 1999 Subscription Rates

U.R.S.I. correspondents & AGU Members ..... \$65.00  
AGU Student members ..... \$33.00

## Outside the USA

Surface Postage ..... \$18.00  
Air Freight Postage ..... \$53.00  
Air Mail Postage ..... \$82.00

## Subscribe Today:

**By Phone:** North America: +1-202-462-6900  
**By Fax:** Europe: +49-5556-1440  
**By E-Mail:** orders@kosmos.agu.org  
agu@copernicus.org

Or write: AGU - Orders  
2000 Florida Avenue, N.W.  
Washington, DC. 20009

## Submit to *Radio Science*

Send 5 copies of the manuscript to the Editor at the following address:

Robert Hunsucker  
c/o Paul Cooper, Editor Assistant  
AGU  
2000 Florida Ave., NW  
Washington, DC 20009  
Ph: 202-462-6910 x 365  
E-mail: pcooper@kosmos.agu.org

The cover letter should include the author's telephone number, fax number, and e-mail address, and the names, addresses, telephone numbers, fax numbers, and e-mail addresses of five potential reviewers.

# RADIO SCIENCE

Volume 33 Number 2 March - April 1998

Published by  
American Geophysical Union  
Cospponsored by  
International Union of Radio Science



Cospponsored by  
U.R.S.I. International  
and published  
bimonthly by AGU.

Members of the  
Network of U.R.S.I.  
Correspondents may  
subscribe at the AGU  
member rate!



# AGU

URSI

## SPECIAL OFFER TO URSI CORRESPONDENTS

### AIMS AND SCOPE

*The Journal of Atmospheric and Solar-Terrestrial Physics* is an international journal concerned with the interdisciplinary science of the Earth's atmospheric and space environment. Papers are published on the results of experiments and their interpretations, and on theoretical or modelling studies. Papers dealing with remote sensing carried out from the ground or with *in situ* studies made from rockets or from satellites orbiting the Earth are particularly suitable. Plans for future research, often carried out as an international programme, are also discussed. Besides original research papers, discussion papers and short reports, the journal includes commissioned review papers on topical subjects and special issues arising from chosen scientific symposia or workshops. The journal covers the physical processes operating in the troposphere, stratosphere, mesosphere, thermosphere, ionosphere, magneto-sphere and heliosphere. Phenomena occurring in other "spheres" and supporting laboratory measurements are also considered. The journal deals especially with the coupling between the different regions. Regarding the upper atmosphere, the subjects of aeronomy, geomagnetism, auroral phenomena, radio wave propagation and plasma instabilities are examples within the broad field of solar-terrestrial physics which emphasise the energy exchange between the solar wind, the magnetospheric and ionospheric plasmas, and the neutral gas. In the middle and lower atmosphere, the topics covered include dynamics, radiation and chemistry, atmospheric electricity and electrodynamic effects, including lightning and its effects, and anthropogenic changes. Helpful, novel schematic diagrams are encouraged as is the use of colour.

**Complementary information about this journal including full text articles, and other features**  
<http://www.elsevier.nl/locate/JASTP>

### Audience:

Atmospheric physicists, geophysicists and astrophysicists.

### Abstracted/indexed in:

Cam Sci Abstr  
Curr Cont SCISEARCH Data  
Curr Cont Sci Cit Ind  
Curr Cont/Phys Chem & Sci  
INSPEC Data  
Meteoro & Geoastrophys Abstr  
Res Alert

PERGAMON - An imprint of Elsevier Science

### Editor-in-Chief:

**Michael J. Rycroft**, *International Space University*  
Parc d'Innovation, Bd Gonthier d'Andernach,  
67400 Illkirch, France

### North American Editor-in-Chief:

**T.L. Killeen**, *Space Physics Research Laboratory*,  
The University of Michigan, 1424 Space Research  
Building, 2455 Hayward Street, Ann Arbor,  
MI 48109-2143, USA

### Special Rate for URSI Correspondents 1999: NLG 259.00 (US\$ 132.-)

### Subscription Information

1999: Volume 61 (18 issues)

Subscription price: NLG 4471.00 (US\$ 2270.00)

ISSN 1364-6826 (00211)

Associated Personal Price: NLG 259.00/ US\$ 132,—

### CONTENTS DIRECT:

The table of contents for this journal is now available pre-publication, via e-mail, as part of the free ContentsDirect service from Elsevier Science. Please send an e-mail message to [cdhelp@elsevier.co.uk](mailto:cdhelp@elsevier.co.uk) for further information about this service.

### For ordering information please contact:

#### Elsevier Science Offices:

#### For customers in the Americas

(North, South and Central America):

Elsevier Science

Regional Sales Office

Customer Support Department

655 Ave. of the Americas

New York, NY 10010, USA

Tel.: +1-212-633.3730

Toll-free for customers in the USA and Canada:

1-888-437.4636 (1-888-4ES-INFO)

Fax: +1-212-633.3680

E-mail: [usinfo-f@elsevier.com](mailto:usinfo-f@elsevier.com)

#### For customers elsewhere:

Elsevier Science Ltd.

The Boulevard

Langford Lane

Kidlington

Oxford OX 5 1GB, UK

Fax: +44 (0) 1865 843952

E-mail: [freesamples@elsevier.co.uk](mailto:freesamples@elsevier.co.uk)



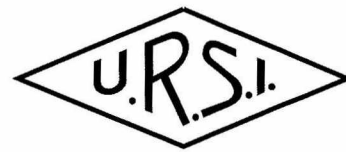

## Content

The Radio Science Bulletin is published 4 times a year by Radio Science Press on behalf of URSI, the International Union of Radio Science. Besides general and administrative information issued by the URSI Secretariat, the Bulletin includes a scientific section containing articles and correspondence items (short notes, letters to the editor and book reviews). Contributed papers are preferably of a tutorial nature and should be of interest to a wide range of persons belonging to the Radio Science Community. The subject matter should relate to the analysis and applications of Radio Science in areas of principal or broad interest.

Articles are subject to peer-reviewing. The content should be original and must not duplicate descriptions or derivations available elsewhere. Submission of a manuscript manifests the fact that it has been neither copyrighted, published, nor submitted or accepted for publication elsewhere, unless otherwise so stated by the author. The manuscript text should not contain any commercial references, such as company names, university names, trademarks, commercial acronyms, or part numbers. All material not accepted will be returned. Accepted material will not be returned unless asked by the authors on submission.

## Length

Articles can vary in length but are preferably 7 to 15 double-spaced typewritten pages (A4 size) in length, plus up to 10 pages of figures. Correspondence items are of less than 3 double-spaced typewritten pages, plus not more than 1 page of figures.

## Submissions

All material submitted for publication in the scientific section of the Bulletin should be addressed to the Editor, whereas administrative matters are to be handled directly with the URSI Secretariat. Submission in electronic format according to the instructions below is preferred. In addition, a paper copy of your manuscript should be sent to the Editor, accompanied by a separate sheet containing the address to which correspondence can be sent. Also enclose original illustrations in case the electronic format yields problems of quality or compatibility.

## Styles

The official languages of URSI are French and English. Articles in either language are acceptable. No specific style for the manuscript is required as the final layout of the paper is done at the URSI Secretariat. Name, affiliation, address and telephone/fax numbers for all authors are required. Figure captions should be on a separate sheet in proper style for typesetting. See this issue for examples.

Originals of drawings and glossy print black-and-white photographs should be sharp and of good contrast. Line drawings should be in black ink on a white background. Prefer A4 size sheets to simplify handling of the manuscript. Template lettering is recommended; typing on figures is not acceptable. Lettering should be large enough to permit legible reduction of the figure to column width, perhaps as much as 4:1. Identify each illustration on the back or at the bottom of the sheet with the figure number and name of author(s). Indicate the top of a photograph. Captions lettered

on figures will be blocked out in reproduction in favor of typeset captions. If possible also provide the figures in electronic format, preferably in TIF-format. MacDrawPro, CricketGraph, Microsoft Excel, Adobe Illustrator are possible as well as postscript files (PS) and EPS formats.

## Electronic Submission

As the final editing will be done using Aldus Pagemaker 6.5 on Macintosh, the paper can be submitted in Microsoft Word (for Macintosh or IBM Compatible) in any version. Wordperfect is also acceptable. *It is important to mail the Editor a paper print out of your article for comparison.*

The files can be sent to the Editor in three ways:

- 1) By sending a floppy diskette. Both Macintosh (low and high density) and IBM-PC, 3.5 inch, 720 kb or 1.44 Mb disk formats are acceptable. The following information is needed:
  - \* The operating system and word processing software used to produce your document should be noted on your disk (e.g. DOS/WordPerfect).
  - \* The disk should be labeled with the file name(s) relating to the manuscript.
  - \* No program files should be included on the disk.
  - \* Package floppy disks in such a way as to minimize possible damage in transit.
  - \* Include a flat ASCII version on the disk with the word-processed version, if possible.
- 2) By sending an e-mail message to the Editor.
- 3) By putting your submission on a ftp site. For this purpose:
  - \* Open the ftp site at address *ftp.tele.ucl.ac.be* ,
  - \* Login as *anonymous* ,
  - \* Password: *your e-mail address* ,
  - \* In the directory */pub/URSI*, create your own directory,
  - \* Change to this directory and put your text and/or figures there,
  - \* Send an e-mail message to the Editor (*Sobieski@tele.ucl.ac.be*) to draw his attention to the fact that the files have been transferred.

## Review Process

The review process usually requires about three months. The author is then notified of the acceptance/rejection decision of the Editor or Associate Editor based on reviewer recommendations. The authors may be asked to modify the manuscript if it is not accepted in its original form. The elapsed time between receipt of a manuscript and publication is usually less than twelve months.

## Page Charges

No page charges are applied for any contribution following the above mentioned guidelines. No free reprints will be issued.

## Copyright

Publication of papers in the Radio Science Bulletin is subject to copyright transfer to Radio Science Press acting as agent and trustee for URSI. Submission of a paper for publication implicitly indicates the author(s) agreement with such transfer and his certification that publication does not violate copyrights granted elsewhere.

# APPLICATION FOR AN URSI CORRESPONDENT

I wish to become an URSI Correspondent for the remainder of the 1997-1999 triennium.  
Subscription to *The Radio Science Bulletin* is included in the fee.  
(please type or print in BLOCK LETTERS)

Name: Prof./Dr./Mr./Mrs./Ms. \_\_\_\_\_  
*Family Name* *First Name* *Middle Initials*

Present job title: \_\_\_\_\_

Years of professional experience: \_\_\_\_\_

Professional affiliation: \_\_\_\_\_

Company name: \_\_\_\_\_

Department: \_\_\_\_\_

Street address: \_\_\_\_\_

City and postal / zip code: \_\_\_\_\_

Province / State: \_\_\_\_\_ Country: \_\_\_\_\_

This is my  home  business address

Phone: \_\_\_\_\_ ext: \_\_\_\_\_ Fax: \_\_\_\_\_

E-mail: \_\_\_\_\_

## Areas of interest (please tick)

- |                                                                 |                                                                   |
|-----------------------------------------------------------------|-------------------------------------------------------------------|
| <input type="checkbox"/> A Electromagnetic Metrology            | <input type="checkbox"/> F Wave Propagation & Remote Sensing      |
| <input type="checkbox"/> B Fields and Waves                     | <input type="checkbox"/> G Ionospheric Radio and Propagation      |
| <input type="checkbox"/> C Signals and Systems                  | <input type="checkbox"/> H Waves in Plasmas                       |
| <input type="checkbox"/> D Electronics and Photonics            | <input type="checkbox"/> J Radio Astronomy                        |
| <input type="checkbox"/> E Electromagnetic Noise & Interference | <input type="checkbox"/> K Electromagnetics in Biology & Medicine |

The fee is US\$ 20.

(The URSI Board of Officers will consider waiving of the fee if the case is made to them in writing)

Method of payment: VISA / MASTERCARD

Credit Card No             Exp. date: \_\_\_\_\_

Date: \_\_\_\_\_ Signed \_\_\_\_\_

Return this form to:

The URSI Secretariat  
c/o University of Gent / INTEC  
Sint-Pietersnieuwstraat 41  
B-9000 GENT, BELGIUM  
fax (32) 9-264.42.88